



Operation and maintenance

Envistar Flex

Size 060-1580



Order number:

Project name:





Documentation for your unit:

1. Scan the QR code or type docs.ivprodukt.com in your browser.
2. Enter your order number.
3. Press ENTER or click on search.
4. Select your order.

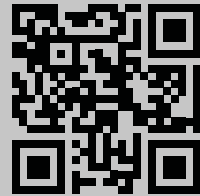

Is any documentation missing?

See information in section
"2.1 Documentation and support", page 10.

Unit specifications

Size

060	360	980
100	400	1080
150	480	1250
190	600	1280
240	740	1540
300	850	1580

Optional extras

Cooling unit ECO, ECX

Reversible heat pump TCH

Reversible heat pump TCR

Home Concept

Control equipment

For more information, refer to the separate Wiring Instructions

MX

US

UC

MK

HS

Unit parts and accessories

Plate heat exchanger EXP

Counter-flow exchanger EXM

Rotary heat exchanger EXR

Run-around coil unit EXL

Air heater water EMT-VV, ELEV

ThermoGuard ESET-TV, ELTV

Air heater electric ESET-EV, ELEE, ELPE
Eff-was 1 2 3 4 5

Air cooler water EMT-VK, ESET-VK,
ELBC, ESET-DX, ELBD, ELDX

Damper ESET-TR, EMT-01

Intake section MIE-IU

Exhaust air section EAU

Recirculating unit EBE

Sound attenuator EMT-02, MIE-KL

Carbon filter section ECF

Filter bypass ENFT-10

For filter class and size, the Technical Data for the unit on IV Produkt's order portal.

Operation and maintenance

Envistar Flex

TABLE OF CONTENTS

1	SAFETY	7
1.1	Intended use	7
1.2	Unintended uses	7
1.3	General safety	7
1.4	Structure of warning notices	8
1.5	General warning notices	8
1.6	Safe shut-off of units	8
1.7	Signs on the unit	8
1.7.1	Type plate.....	8
1.8	Accidents and incidents.....	8
1.9	Product liability	9
1.10	Noise	9
1.11	Handling of refrigerant	9
1.12	Downtime.....	9
1.13	After the product's service life.....	9
2	GENERAL INFORMATION	10
2.1	Documentation and support	10
2.2	Information messages, not safety-related	10
2.3	Spare parts	10
2.4	Terms and abbreviations in the manual.....	10
2.5	Symbols on dimension drawings (technical data)	11
3	DESCRIPTION OF THE UNIT	12
3.1	Configuration of the unit	12
3.2	Orientation of the unit's sides/parts.....	12
3.3	Signs on the unit	12
3.4	Unit functions	13
3.4.1	Filter	13
3.4.2	Rotary heat exchanger - Home Concept	13
3.4.3	Plate heat exchanger - Defrost/freezing	14
3.4.4	Run-around coil unit.....	14
3.4.5	Fan	14
3.4.6	Air heater electric	14
3.4.7	Air heater/air cooler water.....	14
3.4.8	Damper	14
3.4.9	Outdoor intake section.....	14
3.4.10	Outdoor exhaust air section.....	15
3.4.11	Recirculating unit with shut-off/control damper	15
3.4.12	Filter bypass	15

Operation and maintenance Envistar Flex



4	COMMISSIONING AND OPERATION	16
4.1	Starting and stopping the unit	16
5	MAINTENANCE	17
5.1	Maintenance Intervals	17
5.2	Hygiene inspection VDI 6022 (optional extra)	17
5.3	Downtime	17
5.4	Shutting down the unit before maintenance	17
5.5	Starting the unit after maintenance	19
5.6	Maintenance of unit cabinets and surfaces	19
5.7	Maintenance of water trap	19
5.8	Maintenance of filters	20
5.8.1	Replacing disposable bag filter or carbon filter	20
5.8.2	Cleaning the aluminium filter	20
5.8.3	Automatic filter control - FLC	21
5.8.4	Check pressure drop manually (not carbon filter in Home Concept)	21
5.9	Maintenance of rotary heat exchanger	22
5.9.1	Cleaning the rotary heat exchanger	23
5.9.2	Replacing the brush strip	23
5.9.3	Replacing or shortening the drive belt	25
5.9.4	Adjusting the purging sector	26
5.10	Checking differential pressure between supply air (SA) and extract air (EA)	27
5.10.1	Check differential pressure between outdoor air and extract air	27
5.10.2	Checking pressure balance/leakage function - Home Concept	28
5.10.3	Adjusting the rotary heat exchanger	28
5.11	Maintenance of the plate heat exchanger	29
5.11.1	Cleaning the heat exchanger	29
5.11.2	Checking damper for defrosting function (ODS)	29
5.11.3	Checking damper for freeze protection (BYP)	30
5.12	Maintenance of fan	30
5.12.1	Clean fan and motor	31
5.12.2	Checking/adjusting overheat protection	31
5.12.3	Check air flow	31
5.12.4	Check the ring line for flow measurement	32
5.13	Maintenance of run-around coil unit	32
5.13.1	Checking valve actuator recovery circuit	33
5.14	Maintenance of air heater/air cooler water	34
5.14.1	Clean the coils	34
5.14.2	Checking that the air heater regulates heating/cooling	34
5.14.3	Bleeding the coil	35
5.14.4	Additional maintenance of Thermoguard coil	35

Operation and maintenance

Envistar Flex

5.15	Maintenance of air heater electric	36
5.15.1	Cleaning the air heater electric	36
5.15.2	Checking the overheat protection	36
5.16	Maintenance of damper and filter bypass	37
5.16.1	Cleaning the damper and filter bypass	37
5.16.2	Checking/adjusting the damper	37
5.16.3	Checking the gaskets	37
5.17	Maintenance of intake section, exhaust air section, recirculating unit	38
5.18	Maintenance of sound attenuator	38
5.18.1	Cleaning the extendible baffle	38
5.19	Maintenance of humidifier	38
6	ALARM	39
6.1	Reset alarms after action	39
6.2	Fire alarm (fire damper, fire fan)	39
6.3	Alarm filter	39
6.4	Temperature/cooling/freeze protection alarm	40
6.5	Other alarms	40
7	TROUBLESHOOTING	41
8	DECOMMISSIONING AND RECYCLING	42
8.1	Disposal and recycling	42
8.2	Before disassembly	42
8.3	Dismantling the unit	43
8.4	Material content	43
9	SERVICE SCHEDULE	44

1 SAFETY

This section addresses important safety aspects of assembly, with the aim of raising safety awareness and avoiding personal injuries and damage to surroundings and units.

For units in vulnerable environments, servicing and maintenance are essential for maximum service life and maintained warranty. Follow the applicable operating and care instructions for each unit part in this document.



- This manual contains important instructions. Read it carefully and follow the instructions.
- Pay special attention to warning and information messages, as well as markings on the product.
- Keep the manual for future use.

00177

1.1 Intended use

Intended use

The unit is intended for use as an air handling unit for comfort ventilation in buildings.

Intended users

The contents of this manual are intended for personnel who commission, manage operation, and carry out regular maintenance of the unit.

Intended user environment

- The unit is usually placed indoors, but is also available as an outdoor version.
- When assembled indoors, the unit must be assembled in a ventilated area that maintains a temperature between +7 and +30 °C, and that maintains a moisture content of <3.5 g/kg in dry air in the winter.
- The unit can also be equipped for assembly in cold attics.

1.2 Unintended uses

Only uses specified in Intended Use are permitted. The unit must not be used in potentially explosive environments.

1.3 General safety

Failure to comply with the safety precautions may result in injury to persons or damage to air handling units. To avoid personal injuries and damage to surroundings or units:

- Follow national and local laws/regulations for safe work, e.g. fall protection when working at a height.
- Do not wear loose clothing or jewellery that may become fastened.
- Do not step or climb on the unit.
- Use appropriate tools.
- Use appropriate personal protective equipment.
- Note the unit's markings, product signs, information labels and warning stickers.

Personal Protective Equipment (PPE)

Personal protective equipment must always be used based on the risks present in the workplace. For example, wear protective footwear with steel toecaps, hearing protection, safety helmet, gloves, safety eyewear or goggles, fully-covering clothing, safety overalls, face mask/protective mask and/or fall protection where the work and work environment require it.



Operation and maintenance

Envistar Flex

1.4 Structure of warning notices

Warning notices in the instruction warn of risks when handling and assembling the product. Carefully follow the instructions published in warning notices.



The warning symbol indicates that a risk exists.

WARNING! indicates a potential risk that, if not avoided, can cause **life-threatening or serious** situations that can lead to death or personal injury.

CAUTION! indicates a potential risk that, if not avoided, can cause **material damage** to the product or surroundings as well as impairment of product function.

"**Risk of xxxxxx.**" Indicates the risk in a short risk title.

A description in italics provides more detailed information about what the risk entails.

- The bullet points indicate how the user avoids harm.

1.5 General warning notices

Refer to warnings in section "[5 MAINTENANCE](#)", [page 17](#).

1.6 Safe shut-off of units

Before and during maintenance and servicing, follow the instructions and read the warnings in Section "[5.4 Shutting down the unit before maintenance](#)", [page 17](#).

1.7 Signs on the unit

Keep signs and stickers free of dirt. Replace missing, damaged or unreadable signs and stickers on the machine. Contact IV Produkt for replacement stickers.

1.7.1 Type plate

The unit and any associated cooling unit/reversible heat pump have a type plate affixed to the front. The type plate is used, among other things, for identification of the product.

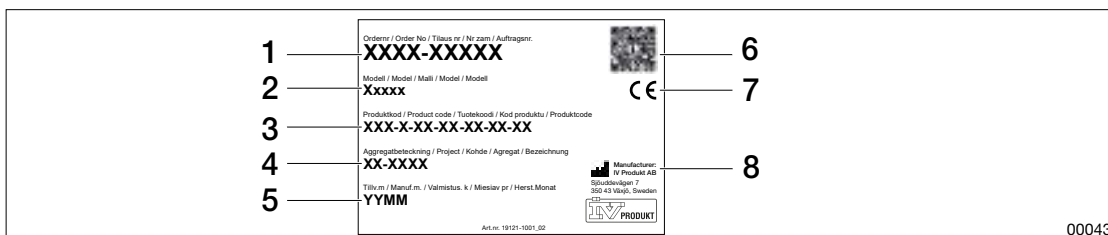

Figure: Example of a unit type plate

- | | |
|-----------------------|------------------------|
| 1. Order number | 5. Date of manufacture |
| 2. Product name/model | 6. QR code |
| 3. Product code | 7. CE mark |
| 4. Unit designation | 8. Manufacturer |

1.8 Accidents and incidents

Report accidents and incidents according to national and local laws/regulations.

1.9 Product liability

The unit complies with industry requirements for quiet air handling units with high-efficiency recovery systems for heating and cooling.

CE marking

The air handling unit is CE marked and meets the requirements according to specified directives and standards in the Declaration of Conformity. The marking covers the unit in the configuration in which it was delivered and provided that it has been assembled and commissioned in accordance with IV Produkt's instructions. The declaration does not cover units that have been modified, retrofitted components, or other systems in which the unit may be included. The unit may not be put into service until the plant in which it is included complies with the requirements for CE-marking.

The Declaration of Conformity can be found at IV Produkt's order portal. See "[Documentation for your unit.](#)", page 2.

Manufacturer

The Air Handling Unit is manufactured by IV Produkt AB, Sjöuddevägen 7, S-350 43 VÄXJÖ, Sweden.

Warranty

For proper function and for the warranty to be valid, IV Produkt's assembly instructions must be followed.

Extended warranty

Extended warranty is a supplement to the order and to claim extended warranty (5 years), according to ABM07 with Appendix ABM-V07 or according to NL17 with Appendix VU20, a complete documented and signed IV Produkt Service and Warranty book must be presented.

Disclaimer

Continuous product development may give rise to specification changes without notice.

1.10 Noise

	<p>WARNING! Risk of personal injury due to high noise levels. <i>High noise levels can cause damage to hearing.</i></p> <ul style="list-style-type: none">• Check the noise level in the current operation point. See information in Technical Data for the unit in question.• Comply with local and national regulations for work at higher noise levels.	00259
---	---	-------

Hearing protection is recommended for extended work in noisy environments, such as plant rooms.

1.11 Handling of refrigerant

Se separat Drift och skötsel för kylaggregat EcoCooler eller kylvärmepump ThermoCooler HP.

1.12 Downtime

For more information, refer to "[5.3 Downtime](#)", page 17.

1.13 After the product's service life

For disassembly and decommissioning, see "[8 DECOMMISSIONING AND RECYCLING](#)", page 42.



2 GENERAL INFORMATION

2.1 Documentation and support

The documentation for your unit can be found in the Order Portal. Refer to "[Documentation for your unit:](#)", page 2.

It can take up to two weeks for all documentation to be available in the Order Portal. The text "Documentation in progress" appears until the documentation is complete. In case of missing or incorrect documentation, contact DU/Documentation. For other support, please contact the relevant department. See contact details on the last page of the manual.

2.2 Information messages, not safety-related



Symbol together with information text highlights difficulties and also gives tips and recommendations.

00182

2.3 Spare parts

Spare parts list can be found in the Order Portal. Order spare parts and accessories from IV Produkt. See contact details on the last page of the manual. When contacting a department, state the order number and unit designation as shown on the type plate located on the unit.

2.4 Terms and abbreviations in the manual

Term	Explanation
Thermal wheel	Rotary heat exchanger
Unit part	Part of the unit. Can contain a function (for example, fan, media, etc.) but can also be an empty part.

2.5 Symbols on dimension drawings (technical data)

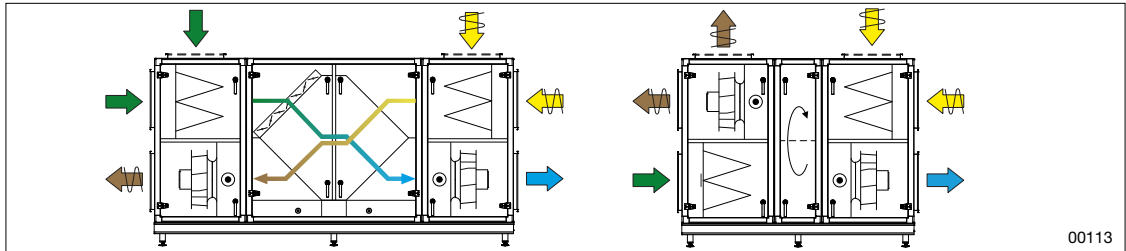

Figure: Example of a layout drawing

	Outdoor air		Extract air
	Supply air		Exhaust air
	Fan		Filter
	Shut-off damper		Trim damper
	Air cooler water		Air heater water
	Air heater electric		Noise attenuator
	Rotary heat exchanger		Plate heat exchanger
	Counterflow heat exchanger		Compressor
	Cooling unit		Reversible heat pump
	Media section/Control cabinet		Quick connector



Operation and maintenance Envistar Flex

3 DESCRIPTION OF THE UNIT

3.1 Configuration of the unit

The unit is available in different sizes 060-1580 and in right-hand or left-hand configurations. The framework of the units consists of aluminium profiles.

3.2 Orientation of the unit's sides/parts

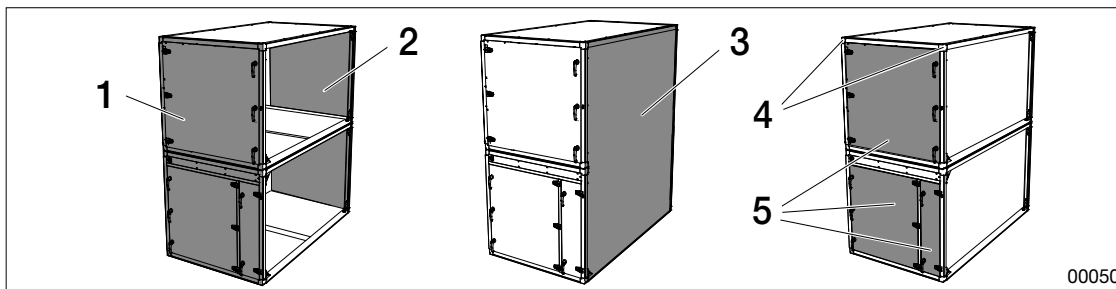





















Figure: Parts of the unit

- 1. Access side
- 2. Back
- 3. Gable side
- 4. Joints
- 5. Covers

3.3 Signs on the unit

- | | | | |
|---|-----------------------|---|-------------------------------|
|  | Filter |  | Air turner |
|  | Rotary heat exchanger |  | Flue gas bypass from above |
|  | Plate heat exchanger |  | Flue gas bypass from the side |
|  | Fan |  | Media |
|  | Air cooler water |  | Empty |
|  | Air heater liquid |  | Humidifier |
|  | Air heater electric |  | Angle |
|  | Damper |  | Earth |
|  | Noise attenuator |  | Inspection |
|  | Temperature sensors | | |

3.4 Unit functions

For more information, refer to *"5 MAINTENANCE", page 17.*

3.4.1 Filter

Different filters have different dirt accumulation capacities. When replacing them, filters of the same quality and capacity of those originally supplied must be used. Refer to the Technical Data document or the Spare Parts list.

Bag filter: Bag filters cannot be reused. Used filters must be disposed of in accordance with applicable environmental regulations.

Aluminium filter: Aluminium knitted flat filter, used for extract air containing grease particles.

Carbon filter: Carbon filters are compact and highly efficient molecular filters used to eliminate odours in the system. The filters are combustible in their entirety. Their function and service life depend on the volume of air that passes through and on the molecular density of odorous substances.

Carbon filter with filter control (FLC) for units with MX control equipment: FLC is an automatic filter control system that calculates and alerts when the preset amount of air has been exceeded. The FLC value can be adjusted to the system. To change the value, refer to separate control documentation for Climatix.

3.4.2 Rotary heat exchanger - Home Concept

Units in the Home Concept configuration are equipped with a function to control the pressure balance to ensure the correct leakage function and purging function. The trim damper automatically regulates the pressure balance according to the set value in the control unit. For units supplied with MX control equipment, the function is connected at the factory. In units delivered without control equipment, the function must be connected by the customer. The purging sector is set to its maximum open value upon delivery.

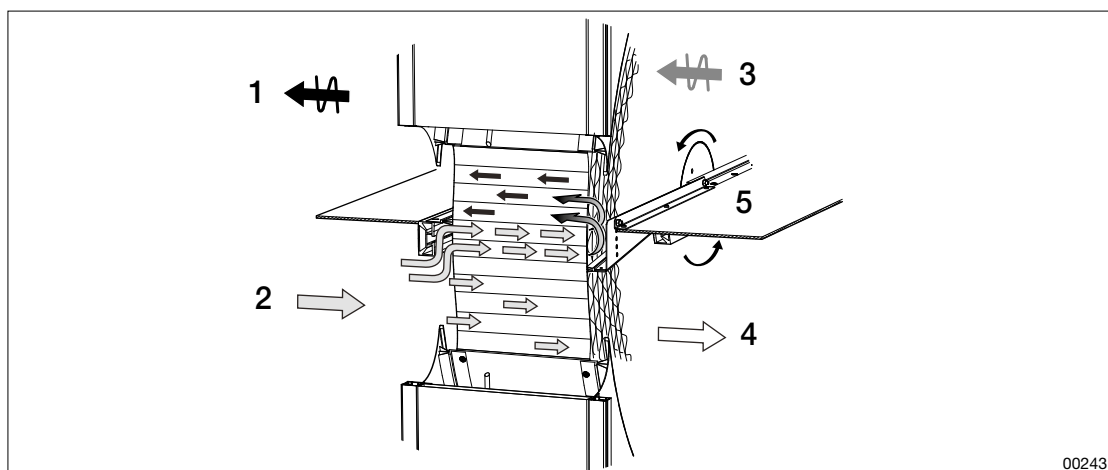

Figure: Purging sector maximum open (from factory)

- | | | | | |
|----------------|----------------|----------------|---------------|-------------------------------------|
| 1. Exhaust air | 2. Outdoor air | 3. Extract air | 4. Supply air | 5. Thermal wheel rotation direction |
|----------------|----------------|----------------|---------------|-------------------------------------|



Operation and maintenance

Envistar Flex

3.4.3 Plate heat exchanger - Defrost/freezing

Defrost function ODS (EXMM-XP/NP)

The defrost function regulates the dampers to defrost the plate heat exchanger after ice formation. The program is pre-set upon delivery and may not be adjusted or modified without support from IV Produkt.

Freeze protection BYP (EXMM-NP, EXPP-NO/NP/XP)

The freeze protection regulates the dampers on the outdoor air side of the plate heat exchanger to prevent freezing. For units with MX control equipment, the program is pre-set upon delivery and must not be adjusted or changed without support from IV Produkt. For units without control equipment (MK, US, UC), it must be programmed and integrated into external control equipment by the customer.

3.4.4 Run-around coil unit

The run-around coil unit consists of the extract air coil and the supply air coil mounted in the casing.

3.4.5 Fan

The centrifugal fans are mounted on supports equipped with vibration dampers.

3.4.6 Air heater electric

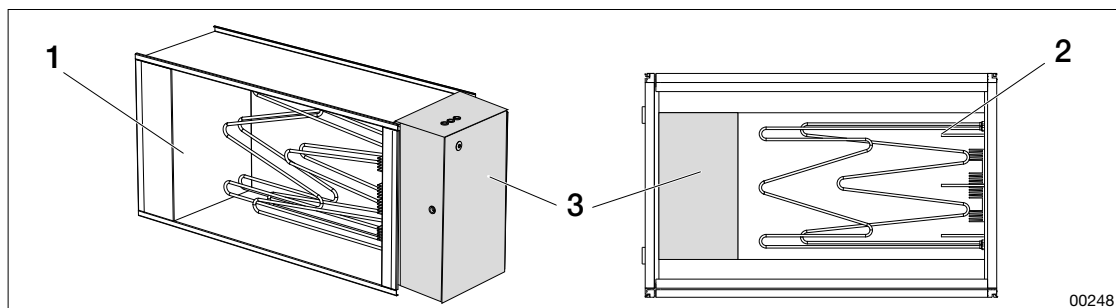

1. Air heater electric (ESET-EV)

2. Air heater electric (MIE-EL/ELEE)

3. Connection box

3.4.7 Air heater/air cooler water



CAUTION!

Risk of damage to Thermoguard air heater.

Start-up of a frozen air heater can severely damage or destroy the product.

- Ensure that the air heater is fully thawed before putting into operation

Thermoguard coil

The coil has a built-in pressure relief valve that prevents the coil from freezing.

3.4.8 Damper

Dampers, such as shut-off/control dampers and trim dampers with manual control, may be placed at different locations in the system.

3.4.9 Outdoor intake section

The intake section consists of intake louvre and drainage. Shut-off dampers are available as optional extras.

3.4.10 Outdoor exhaust air section

The exhaust air section consists of exhaust air louvre and drainage. Shut-off dampers are available as optional extras.

3.4.11 Recirculating unit with shut-off/control damper

The recirculating unit with shut-off/control damper is used to recirculate air when heating premises at night and to modulate recirculating air.

3.4.12 Filter bypass

The filter bypass allows for redirection of the air flow past filters in the event of a fire.



4 COMMISSIONING AND OPERATION

Commissioning of the unit must be carried out by qualified personnel in accordance with documentation from IV Produkt. See "[Documentation for your unit:](#)", page 2.

Documents for commissioning:

- Commissioning record (for units supplied with MX control equipment)
- Control diagrams
- Wiring instructions (separate manual for general connection and external fuse)

Prior to commissioning, the customer shall ensure:

- that electricity is connected via a lockable safety switch.
- that the air heater/air cooler is connected.
- all ducts have been connected.
- that there are no loose parts inside the unit.

4.1 Starting and stopping the unit



The safety switch is not designed for start-up and/or shutdown of the unit.

During operation: Start and shut down the unit via the service switch in the control equipment.

During maintenance and servicing, also switch off the unit via the safety switch. Refer to "[5.4 Shutting down the unit before maintenance:](#)", page 17.

5 MAINTENANCE

5.1 Maintenance Intervals

Checks and actions should be performed at least every 12 months and/or as needed. Refer to recommended maintenance in the section on the respective unit part. A service list to facilitate maintenance is provided at the end of the manual.

5.2 Hygiene inspection VDI 6022 (optional extra)

For inspecting and maintaining hygiene according to the VDI 6022 standard, follow the instructions in this document and additional maintenance in separate documentation in the Order Portal.

5.3 Downtime

In case of prolonged standstill in air treatment systems (more than 48 hours), it should be ensured that no moist areas can be found downstream of the cooling coils or humidifier.

To avoid the accumulation of moisture in the unit – turn off the cooling coils and humidifier in good time and ventilate the air ducts until dry (gradual shut-down). Also set or program automatic dry blowing of the air cooler and downstream sections.

5.4 Shutting down the unit before maintenance



WARNING!
Risk of personal injury.

During operation, an overpressure can be created inside the unit.

- Allow the pressure to drop before you open the inspection doors.

00187



WARNING!
Risk of serious injury; shock or burns.

Applies to installed lighting EMMT-07: The lighting is supplied externally and does not switch off when power is cut through the unit's safety switch.

- Before maintenance or servicing, ensure that there is no power supply to the lamp.

00326



WARNING!
Risk of life-threatening or serious personal injury.

Electrical voltage can cause electric shock, burns and death. The unit must be turned off during maintenance.

- Shut down the unit at the service switch in the control equipment.
- Turn all safety switches to the 0 position. Note that the unit's parts may have separate safety switches.

00327



Operation and maintenance

Envistar Flex

WARNING!
Risk of pinch injury, crush injury or cutting injury due to moving parts.



The device may start unexpectedly during remote control or demand-driven start-up.

- Control parameters may only be changed by personnel with extended privileges.
- The device must be turned off with all safety switches before covers can be opened.

00257

WARNING!
Risk of crushing, compression injury or cuts.



There is no contact guard on moving parts, such as rotating fan impellers, rotary heat exchangers and opening/closing dampers.

- The unit must not be powered until all ducts are connected.
- When the unit is in operation, inspection doors must be closed and locked.
- During service or other procedures, the unit must be switched off.
- Ensure power is off before placing hands in moving parts.
Fan inspection door: Wait at least 3 minutes after shutting down the unit before opening the door.
- Rotary heat exchanger inspection door: Wait at least 3 minutes after shutting down the unit before opening the door.
- Damper inspection door: Wait at least 3 minutes after shutdown before opening the hatch.
- Make sure that hands do not get caught in dampers that have a spring return (which can be closed even when not powered).

00185

WARNING!
Risk of burns.



The parts, pipes and components of the unit may be hot during and after operation of the unit.

- When the unit is in operation, inspection hatches must be closed and locked.
- During service or other interventions, the unit must be switched off.
- Inspection hatch for cooling unit/reversible heat pump: Wait at least 30 minutes after shutting down the unit before opening the compressor door.
- Inspection hatch for heating coil: Wait at least 5 minutes after shutting down the unit before opening the door.

00184

 The safety switch is not designed for start-up and/or shutdown of the unit.

The unit must always be switched off before inspection or maintenance begins. A torch or head lamp should preferably be used for inspection and maintenance.

1. Read "[1 SAFETY](#)", page 7.
2. Read the warnings at the beginning of this chapter.
3. Switch off the unit via the service switch in the control equipment.
4. Lock all safety switches in the 0 position. Please note that different parts may have separate safety switches.
5. Before opening covers, wait until all fans have stopped.

5.5 Starting the unit after maintenance

1. Reset any alarms. Refer to "[6.1 Reset alarms after action](#)", page 39.
2. Ensure that no loose parts, such as tools, remain in the unit.

5.6 Maintenance of unit cabinets and surfaces



CAUTION!

Risk of damage to the product.

Corrosive substances and strong cleaning agents can damage the surface layer.

- Never use strong cleaning agents or corrosive substances when cleaning the unit.

00183



CAUTION!

Risk of damage to the product.

Swarf from drilling left behind after assembly can lead to corrosion and rust on the surface layer of the unit.

- Make sure that the surfaces of the unit are clean of swarf.

00195

1. Shut down the unit. See "[1.6 Safe shut-off of units](#)", page 8.
2. Vacuum inside.
3. Dry the interior surfaces with a wet cloth. Use warm water and mild (non-corrosive) detergent.
4. For heavy soiling, use an environmentally friendly degreasing agent. Follow the manufacturer's instructions.

5.7 Maintenance of water trap



CAUTION!

Risk of environmental impact.

Depending on the business at which the unit is in operation, the extract air may contain environmentally harmful substances that can condense into drains from the unit.

- Ensure compliance with applicable national and international environmental regulations.

00380

Every 12 months and as needed

Make sure the water trap is working and not clogged.

Slag products and coatings in the water trap can cause flooding in the unit.

1. Open the water trap.
2. Remove and clean the ball.
3. Flush the water trap with warm water; use dishwashing liquid if necessary. Make sure no coatings remain.



Operation and maintenance

Envistar Flex

5.8 Maintenance of filters

**WARNING!****Risk of inhalation of harmful particles.**

When changing filters, particles, such as dust, may come loose from the used filter.

- Wear a protective mask when changing filters.
- Use caution when handling used filters.
- Thoroughly clean the filter cabinet after replacement as particulate matter may become loose and remain in the cabinet.

00325

At least every 12 months

Visually confirm that unit parts are clean inside and outside. See "[5.6 Maintenance of unit cabinets and surfaces](#)", page 19.

Replace filter if dirty or clogged. Check the seal for damage and tightness along the entire filter surface. Replace if necessary. Filter replacement intervals vary depending on the operating mode and the amount of particles and odour emitting substances in the air. Manual control only needs to be done if the unit is not equipped with FLC. See "[5.8.1 Replacing disposable bag filter or carbon filter](#)", page 20 or "[5.8.3 Automatic filter control - FLC](#)", page 21.

Replace the filter if the specified pressure drop is reached or the filter alarm is triggered. See "[5.8.4 Check pressure drop manually \(not carbon filter in Home Concept\)](#)", page 21

5.8.1 Replacing disposable bag filter or carbon filter

1. Shut down the unit. See "[1.6 Safe shut-off of units](#)", page 8.
2. If there is a permanently mounted filter monitor; loosen the necessary measuring hoses for the door/post to open the inspection door.
3. Pull the red handles until the filter comes off the rails and stops.

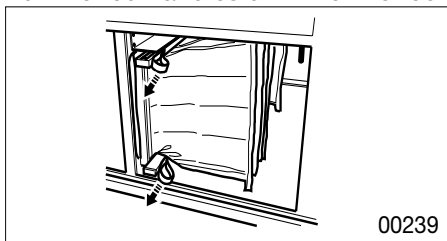

4. Release the handles and grip the filter frame.
5. Pull the filter gently outwards and lift it out carefully.
6. Place the used filter in a rubbish bag/sack and seal. In some filter kits, bags are included for filter replacement.
7. Insert a new filter. Make sure it is pushed as far as it will go into the filter cabinet.
8. Press in the top and bottom filter locks (at the red handles) until a click is heard.
9. Close the inspection door.
10. Dispose of the used filter in accordance with applicable environmental regulations. Refer to "[8 DECOMMISSIONING AND RECYCLING](#)", page 42.

5.8.2 Cleaning the aluminium filter

1. Shut down the unit. See "[1.6 Safe shut-off of units](#)", page 8.
2. When the fans stop, open the inspection door.
3. Pull out filter. See "[5.8.1 Replacing disposable bag filter or carbon filter](#)", page 20.
4. Brush the filter with a soft brush.

5. Gently vacuum the surface with a soft vacuum nozzle.
6. Wipe the filter with a wet cloth or rinse it under warm water. Use mild (non-corrosive) detergent.
7. For heavy soiling, use an environmentally friendly degreasing agent. Follow the instructions on the packaging.
8. Clean the interior of the unit cabinet. See "[5.6 Maintenance of unit cabinets and surfaces](#)", [page 19](#).
9. Refit the filter. See "[5.8.1 Replacing disposable bag filter or carbon filter](#)", [page 20](#).

5.8.3 Automatic filter control - FLC

In units with automatic filter control FLC, the filter alarm is triggered if a filter needs to be replaced.

Reset the filter control function on the hand-held terminal display before starting the unit. For more information, see separate control documentation for Climatix.

5.8.4 Check pressure drop manually (not carbon filter in Home Concept)

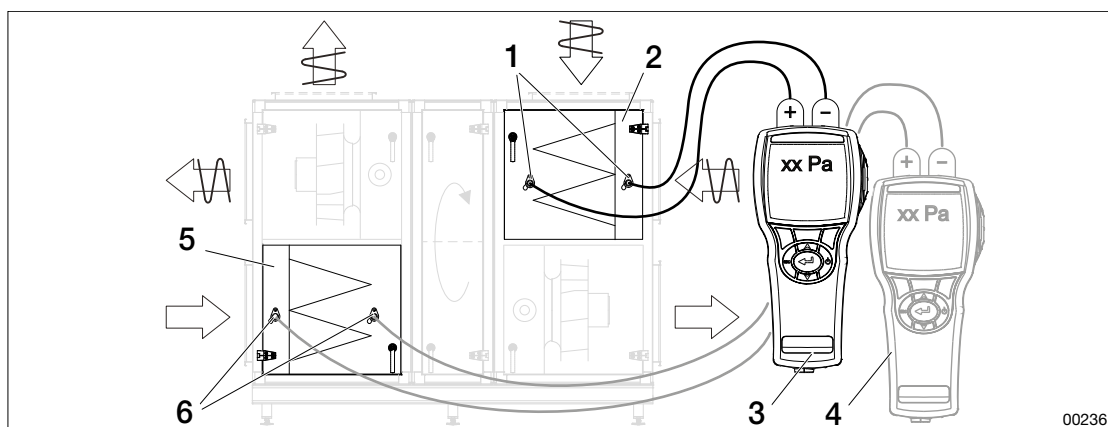

Figure: Check the pressure drop across the filter.

- | | |
|--|--|
| 1. Measuring socket on extract air side | 4. Pressure gauge for supply air side |
| 2. Extract air filter | 5. Supply air filter |
| 3. Pressure gauge for extract air filter | 6. Measuring socket on supply air side |

1. Connect the pressure gauge to the measuring sockets on each side of the extract air filter.
2. Measure the filter pressure drop.
3. Compare the value with the initial pressure drop measured when the unit was commissioned (on the filter section's sign).
4. Replace filter if pressure drop reaches final pressure drop as listed in Technical Data.
5. Repeat the procedure for the supply air filter.



Operation and maintenance

Envistar Flex

5.9 Maintenance of rotary heat exchanger

**CAUTION!****Risk of damage to the product.**

Touch and contact may damage the surface layer of the rotary heat exchanger.

- Make sure that the surface does not come in contact with tools or any part of the body.
- When working with the rotary heat exchanger, wear protective gloves.

00270

Every 12 months and as needed

Visually confirm that unit parts are clean inside and outside. See "[5.6 Maintenance of unit cabinets and surfaces](#)", page 19.

Visually confirm that the thermal wheel surface is clean and free of coatings (dust, etc.) and that the air ducts in the thermal wheel surface are not clogged. See "[5.9.1 Cleaning the rotary heat exchanger](#)", page 23.

Visually confirm that the brush strip is clean and intact and seals against the side plates. Replace brush strip if thermal wheel surface is visible through the brush, if brush strip is broken, or if soiled. See "[5.9.2 Replacing the brush strip](#)", page 23 and spare parts list for new brush strip.

Make sure, by hand, that the thermal wheel rotates easily. If the wheel feels sluggish, check the vertical position of the thermal wheel for abnormal tilting. Refer to Assembly Instructions to adjust the thermal wheel. Make sure brush strips are flush and not damaged. Replace if necessary. See "[5.9.2 Replacing the brush strip](#)", page 23 and spare parts list for new brush strip.

Make sure the drive belt is intact and clean and that it is taut with no slipping. The correct speed is at least 8 rpm when recovery is required. Adjust drive belt if necessary. See "[5.9.3 Replacing or shortening the drive belt](#)", page 25 and spare parts list for new drive belt.

Ensure that pressure balance between measuring sockets P2 and P3 corresponds to the set pressure balance setpoint (-10 Pa) in the control unit. See "[5.10 Checking differential pressure between supply air \(SA\) and extract air \(EA\)](#)", page 27. Adjust trim damper if necessary. See "[5.16.2 Checking/adjusting the damper](#)", page 37.

Check the differential pressure across the thermal wheel and adjust the purging sector if the value is incorrect. See "[5.10.1 Check differential pressure between outdoor air and extract air](#)", page 27 and "[5.9.4 Adjusting the purging sector](#)", page 26.

Ensure pressure balance and leakage function are correct. Adjust the purging sector if the value is incorrect. See "[5.10.2 Checking pressure balance/leakage function - Home Concept](#)", page 28 and "[5.9.4 Adjusting the purging sector](#)", page 26.

5.9.1 Cleaning the rotary heat exchanger



- The thermal wheel's purging function ensures that the ducts do not become clogged. If the air contains sticky dust, manual cleaning may be necessary.
- The rotary heat exchanger is automatically run to prevent odours.
- The bearings and drive motor are permanently lubricated and do not require additional lubrication.
- When applying liquid to the surface of the thermal wheel during cleaning, it is recommended that the unit is running to avoid moisture or excess liquid remaining in the unit. The purging sector should be fully open and the rotational speed should be 8 rpm to ensure adequate detergent intake. Post-rinsing is not normally required.

1. Shut down the unit. See "[1.6 Safe shut-off of units](#)", [page 8](#).
2. When the fans stop, open the inspection door.
3. Gently vacuum with a soft vacuum nozzle.
4. Wipe with a wet cloth or rinse under warm water. Use mild (non-corrosive) detergent.
5. Use low-pressure compressed air to blow the thermal wheel ducts clean. To avoid damage, do not hold the compressed air nozzle closer to the thermal wheel surface than 5-10 mm. Compressed air on the thermal wheel surface of the heat exchanger must not exceed 6 bar.
6. For heavy or oily soiling, spray the thermal wheel surface with a mixture of water and detergent that does not corrode aluminium or with a cleaning agent specifically designed for heat exchangers, such as Re-Coilex.
7. To remove residual odours, spray the surface with a mild alkaline detergent. If possible, apply while the unit is running, so that the cleaner is drawn through the thermal wheel.
8. Clean the interior of the unit cabinet. See "[5.6 Maintenance of unit cabinets and surfaces](#)", [page 19](#).

5.9.2 Replacing the brush strip

Remove and fit a new brush strip to the upper intermediate level

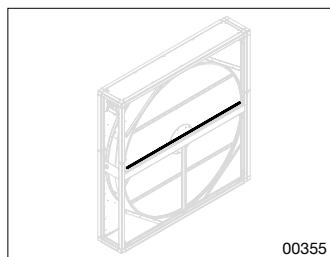

1. Shut down the unit. See "[1.6 Safe shut-off of units](#)", [page 8](#).
2. Unscrew the old strip.
3. Cut a new seal brush strip in the same length as the old one.
4. Screw the new one in the same place as the old one.
5. Make sure it seals against the side plate.

Remove and fit a new brush strip around thermal wheel

1. Shut down the unit. See "[1.6 Safe shut-off of units](#)", [page 8](#).
2. Lift the drive belt off the motor shaft. Make sure that the drive belt does not settle too far out towards the edges as it may get stuck when the thermal wheel is rotated.
3. Rotate the wheel upwards until the brush strip joint is visible.



Operation and maintenance

Envistar Flex

- Continue rotating the wheel while unscrewing the brush strip screws except the two that are on both sides of the joint.

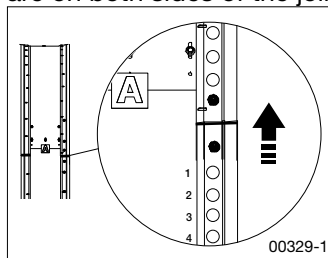

- Hold the brush strip and unscrew the last two screws, above and below the joint. The brush strip is now loose.
- Grip one end and pull out the brush strip completely.
- Cut a new brush strip in the same length as the existing one.
- Place one end of the new brush strip where the old joint was.
- Screw in the first screw closest to the joint. Make sure the brush is flush against the surface of the thermal wheel.

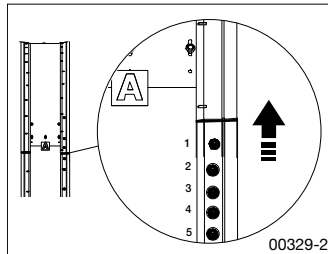

- Rotate the wheel upwards and screw the entire brush strip into the joint using self-tapping screws. Use the holes located on the brush strip. It is sufficient to use every other hole. Preferably make new holes in the thermal wheel. Make sure that the brush is flush against the surface of the thermal wheel at each screw and that it is flush at the joints of the thermal wheel.
- When all screws are in place, insert a thin string into the joint where the ends of the brush strip meet.

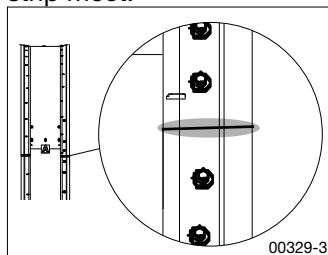

- Open the inspection door next to the thermal wheel on the side where the brush strip has been replaced. Place a putty string between the thermal wheel and brush strip and into the joint so that the brush strip seals.
- Fit the drive belt onto the motor shaft. It does not need to be exactly in the middle. It automatically adjusts when the thermal wheel is running.

5.9.3 Replacing or shortening the drive belt



- The thermal wheel is operated with a round belt or v-belt or depending on the size of the thermal wheel. For the correct belt and belt length, refer to the Spare Parts list.
- Never use grease or other lubricants to push the pin into place in the round belt.

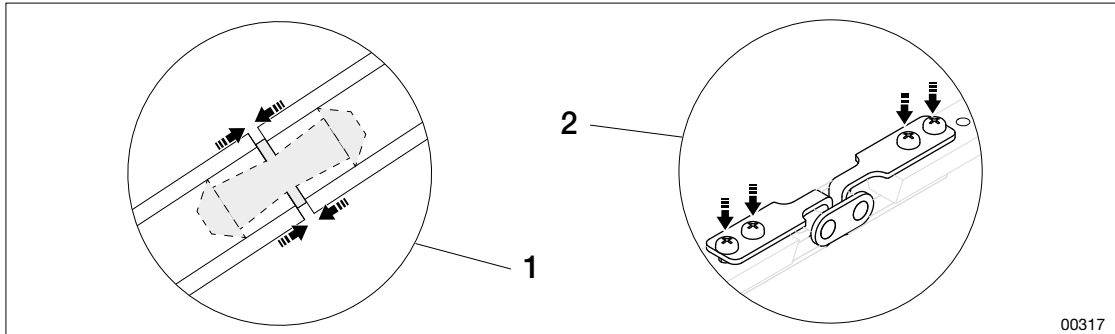

Figure: Cross-section of round belt and v-belt

1. Cross-section of round belt with pin

2. V-belt with v-belt lock

1. Shut down the unit. See "[1.6 Safe shut-off of units](#)", page 8.
2. Remove the old belt.
3. Measure a new belt, or tighten the existing belt by pulling it together to the correct length. For lengths, refer to the Spare Parts list.
4. Cut off the excess.
5. Fit the new belt around the thermal wheel in the same way as the old one. Make sure that the v-belt is properly seated in the motor groove, with the narrow part facing downwards. It is advisable to tape the end so that the belt attaches when the wheel is rotated.
6. Tighten and join the belt using the same method as before.
 - Round belt: Push the round belt over the cones on the pin. Make sure the belt splice is centred over the centre of the pin and as taut as possible. Use tongue-and-groove pliers or a similar tool.
 - V-belt: Screw the v-belt lock onto the new v-belt.
7. Remove the tape when the belt is spliced.

Before starting

1. Reset any alarms. Refer to "[6.1 Reset alarms after action](#)", page 39.



Operation and maintenance Envistar Flex

5.9.4 Adjusting the purging sector

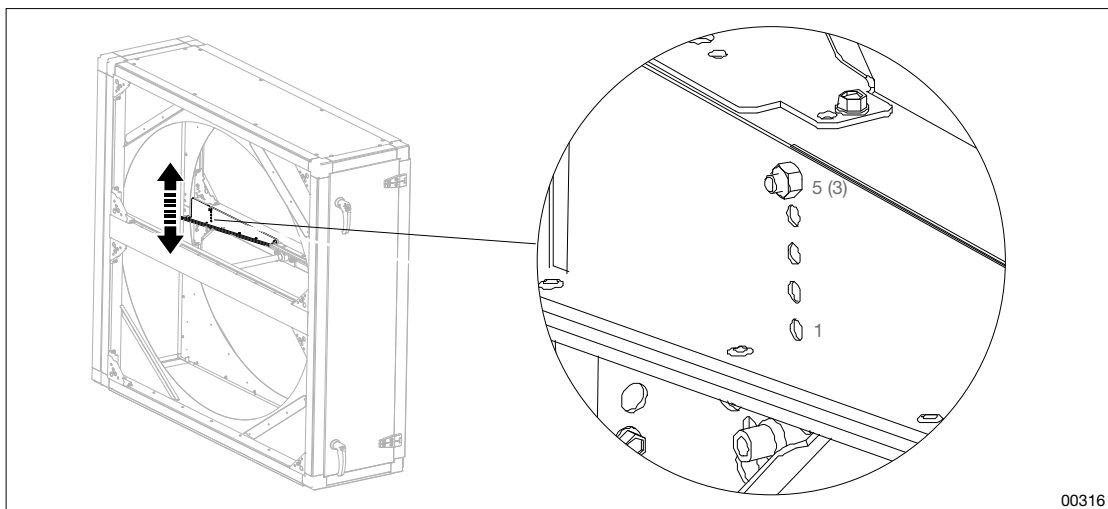
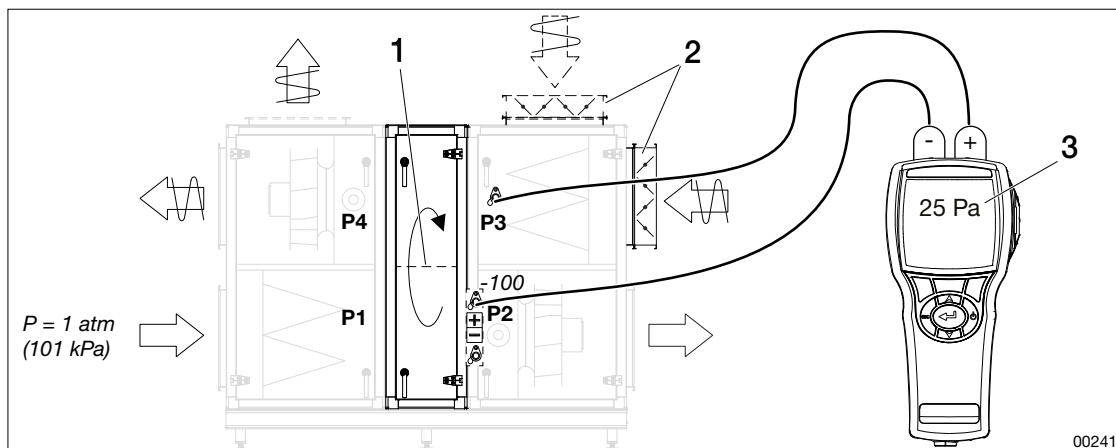

Figure: Purging sector from the back of the thermal wheel. Adjustment holes for setting (3 holes on smaller thermal wheels and 5 holes on larger ones).

1. Shut down the unit. See "[1.6 Safe shut-off of units](#)", page 8.
2. Loosen the screw and move the purging sector plate up or down.
3. Screw the screw into the pre-drilled screw holes according to the following table.

Adjustment hole in the purging sector	Thermal wheel variant: R20, R30, R40, NO, NE, HY, HE, EX	Thermal wheel variant: R50, R60, NP, NX, HP
	Pressure diff. P1 – P3 (Pa)	Pressure diff. P1 – P3 (Pa)
5 (open)	< 200	< 300
4	200 – 400	300–500
3	400–600	500–700
2	> 600	> 700
1 (closed)	-	-

5.10 Checking differential pressure between supply air (SA) and extract air (EA)



1. Purging sector
2. Trim damper
3. Pressure gauge

1. Connect the pressure gauge negative side to P2 and the positive side to P3.
2. Measure the pressure difference.
3. If P3 is greater than P2 or if difference is below 25 Pa, use the extract air side trim damper to throttle pressure balance.

Example:

- P2: SF generates negative pressure in relation to the atmospheric pressure (atm), for example, -100 Pa.
- P3: EF and trim damper generate greater negative pressure than at P2, for example, -125 Pa.

5.10.1 Check differential pressure between outdoor air and extract air

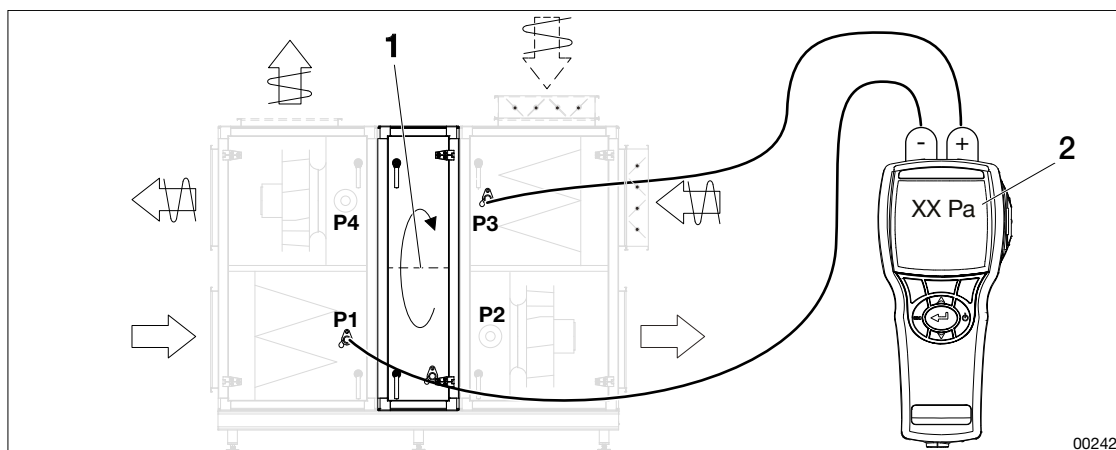

1. Purging sector
2. Pressure gauge

1. Connect the pressure gauge negative side to P1 and the positive side to P3.
2. Measure the pressure difference.
3. Compare values in the table "[5.9.4 Adjusting the purging sector](#)", page 26.
4. If the set value does not match the recommended value, adjust the purging sector.



Operation and maintenance Envistar Flex

5.10.2 Checking pressure balance/leakage function - Home Concept

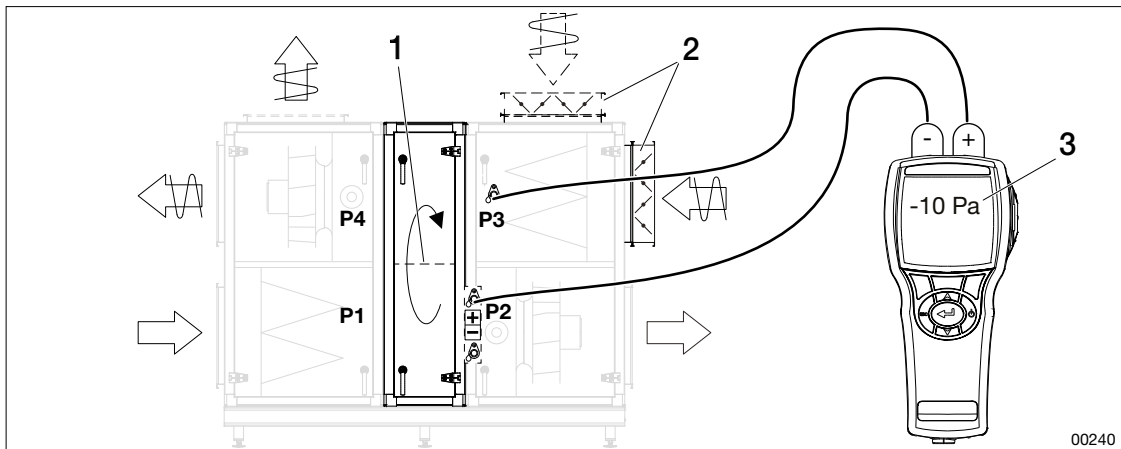

1. Purging sector
2. Trim damper
3. Pressure gauge

1. Connect the pressure gauge negative side to P2 and the positive side to P3.
2. Measure the pressure difference.
3. If the pressure balance does not match the set pressure balance set point in the control unit (-10 Pa), adjust the trim damper.

Example:

- P2: SF generates negative pressure in relation to the atmospheric pressure (atm), for example, -100 Pa.
- P3: EF and trim damper generate greater negative pressure than at P2, for example, -110 Pa.

5.10.3 Adjusting the rotary heat exchanger



- To adjust the thermal wheel, follow the instructions and observe the warnings in the unit's Assembly Instructions. The manual is available at IV Produkt's order portal.

During manufacturing and assembly, the thermal wheel is adjusted to stand straight in the frame, but at high air pressure across the thermal wheel, it may need to be positioned against the direction of air to stand straight during operation.

Control during operation:

1. Open the inspection door and visually check that the brush strip extends equally at the top and bottom of the thermal wheel. Use caution when the inspection door is open. The thermal wheel rotates and there is a moderate pinching hazard at the belt. Do not touch the thermal wheel.
2. If necessary, the thermal wheel can be arranged in a y-direction towards the air direction. For instructions, refer to the unit's Assembly Instructions. When adjusting, the thermal wheel must be turned off.

5.11 Maintenance of the plate heat exchanger

Every 12 months and as needed
Visually confirm that unit parts are clean inside and outside. See " 5.6 Maintenance of unit cabinets and surfaces ", page 19.
Visually confirm that sealing strips are in place, sealed and undamaged.
Visually confirm that the coil fins are clean and undamaged. See " 5.6 Maintenance of unit cabinets and surfaces ", page 19.
Visually confirm that the bypass damper is tightly shut when defrosting is not taking place.
Visually confirm that the dampers are in the correct position (closed or open) depending on whether there is a frost or freeze risk. See " 5.11 Maintenance of the plate heat exchanger ", page 29.
Visually confirm that drip tray, bottom plate, and drain are clean. Clean if necessary.
Ensure that the water trap (without non-return valve) is water filled and not clogged. See " 5.7 Maintenance of water trap ", page 19.
Make sure that the defrost function works. See " 5.11.2 Checking damper for defrosting function (ODS) ", page 29.
Ensure that the freeze protection works. See " 5.11.3 Checking damper for freeze protection (BYP) ", page 30.

5.11.1 Cleaning the heat exchanger

1. Shut down the unit. See "[1.6 Safe shut-off of units](#)", page 8.
2. When the fans stop, open the inspection door.
3. Gently vacuum the coil fins with a soft vacuum nozzle or use low pressure compressed air.
4. Before flushing with warm water, check that the drain and water trap are working.
5. Flush with warm water. Use mild, non-corrosive cleaning agents that do not corrode aluminium. High pressure flushing must not be directed at the fins. Perform flushing carefully to ensure that the fins do not become deformed or break.
6. Clean the interior of the unit cabinet. See "[5.6 Maintenance of unit cabinets and surfaces](#)", page 19.
7. Check and clean the water trap. See "[5.7 Maintenance of water trap](#)", page 19.

At operating temperatures below 0°C, ensure that the heat exchanger is dry before commissioning.

5.11.2 Checking damper for defrosting function (ODS)

The defrost function starts automatically if defrosting is needed. The program is pre-set upon delivery and may not be adjusted or modified without support from IV Produkt.

	Damper over heat exchanger	Bypass damper
Full heat recovery	Fully open	Closed
Shut down unit	Closed	Closed
Defrosting active	In different modes	Partially open



Operation and maintenance Envistar Flex

5.11.3 Checking damper for freeze protection (BYP)

Freeze protection starts automatically when the temperature on the exhaust air side falls below the temperature at a reference point in a given location. For units with MX control equipment, the program is pre-set upon delivery and must not be adjusted or changed without support from IV Produkt. For units without control equipment (MK, US, UC), it must be programmed and integrated into external control equipment by the customer.

	Damper over heat exchanger	Bypass damper
Full heat recovery	Fully open	Closed
Shut down unit	Fully open	Closed
Frost hazard exists	Partially open	Partially open

5.12 Maintenance of fan

Every 12 months and as needed
Visually confirm that unit parts are clean inside and outside. See " 5.6 Maintenance of unit cabinets and surfaces ", page 19 .
Visually confirm that the fan parts are clean and dust-free. See " 5.12.1 Clean fan and motor ", page 31 .
Ensure that: - the fan does not make noise (for example, scraping, knocking, or rattling noises). - the fan does not vibrate or is unbalanced. Well-functioning bearings make a faint humming sound. If the fan appears to be damaged, contact a service technician.
Visually confirm that the fan impeller overlaps the inlet cones.
Visually confirm that the fan rotates in the direction indicated by the markings on the fan. If the fan is in the wrong direction of rotation, contact a service technician.
Visually confirm that mounting screws, suspension devices, supports, vibration dampers and gaskets (around connecting hole) are secure and undamaged. Screw tight or replace if necessary.
Check the ring line for flow measurement. See " 5.12.4 Check the ring line for flow measurement ", page 32 .
Ensure that the overheat protection is working properly. See " 5.12.2 Checking/adjusting overheat protection ", page 31 .
Ensure air flows match settings. See " 5.12.3 Check air flow ", page 31 .

5.12.1 Clean fan and motor

1. Shut down the unit. See "[1.6 Safe shut-off of units](#)", [page 8](#).
2. When the fans stop, open the inspection door.
3. Pull out the fans. Refer to the **Assembly Instructions** for the unit. Note the position of the hoses before pulling them out.
4. Vacuum the fan and motor gently with a soft vacuum nozzle.
5. Wipe the fan impeller and surfaces with a wet cloth. Use warm water and mild (non-corrosive) detergent.
6. For heavy soiling, use an environmentally friendly degreasing agent.
7. Clean the interior of the unit cabinet. See "[5.6 Maintenance of unit cabinets and surfaces](#)", [page 19](#).
8. Refit the fan. Refer to the **Assembly Instructions** for the unit.
9. Ensure that all hoses and connectors are returned to their original location.

5.12.2 Checking/adjusting overheat protection

There is a risk of internal overheating if thick layers of dirt prevent cooling of the stator structure.

Reset overheat protection (applies to ELFF-EC01, -EC02, -ECA2)

1. Cut the power supply to the fan motor.
2. Wait at least 20 seconds after the fan impeller has stopped rotating.
3. Restore power supply to fan motor.

5.12.3 Check air flow.

An excessive pressure drop in the duct system can lead to insufficient supply air flow, which can result in a poor room climate, for example, humid air can be pushed out into the building.

Unit with control equipment (MX)

Read the displayed flow on the hand-held terminal display.

Units without control equipment (UC, MK, US, HS)

1. Measure Δp in the measuring sockets for air flow measurement +/-
2. Read the unit's flow sign to determine which flow corresponds to the measured Δp .

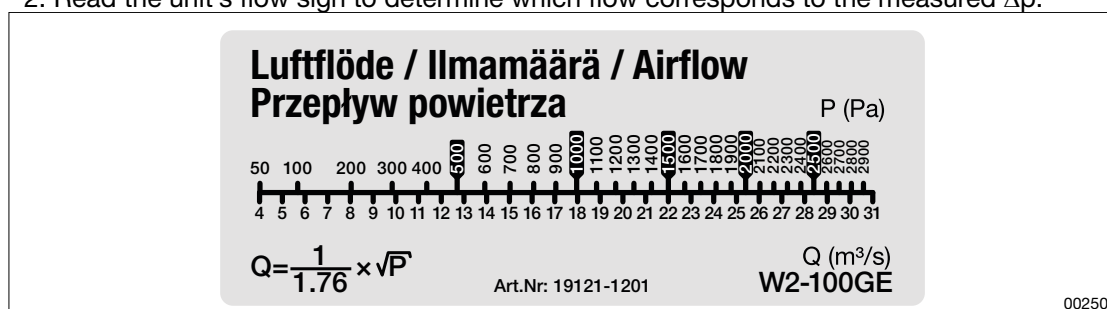



5.12.4 Check the ring line for flow measurement

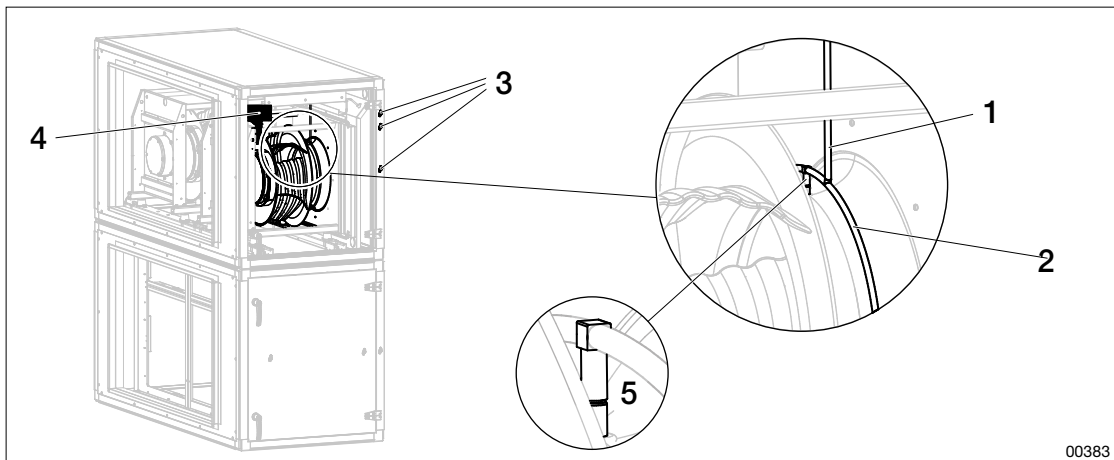

Figure: Check ring line

- | | |
|---------------------|---------------------|
| 1. Measuring hose | 4. Pressure sensors |
| 2. Ring line | 5. Measuring nipple |
| 3. Measuring socket | |

Check hose routing and ensure that:

- the ring line is attached to the respective measurement nipple on the fan cone.
- the ring line is undamaged and does not leak.
- the measuring hose is attached to the ring line.
- the entire hose between the ring line and the pressure sensor/measuring socket is undamaged and is not pinched or leaking.

5.13 Maintenance of run-around coil unit

Every 12 months and as needed

Ensure proper function of the recovery circuit valve actuators. The valve must open or closed when setpoints/conditions change. See "[5.13.1 Checking valve actuator recovery circuit](#)", [page 33](#). If the function is incorrect, contact a service technician.

For maintenance of coil parts, see "[5.14 Maintenance of air heater/air cooler water](#)", [page 34](#).

5.13.1 Checking valve actuator recovery circuit

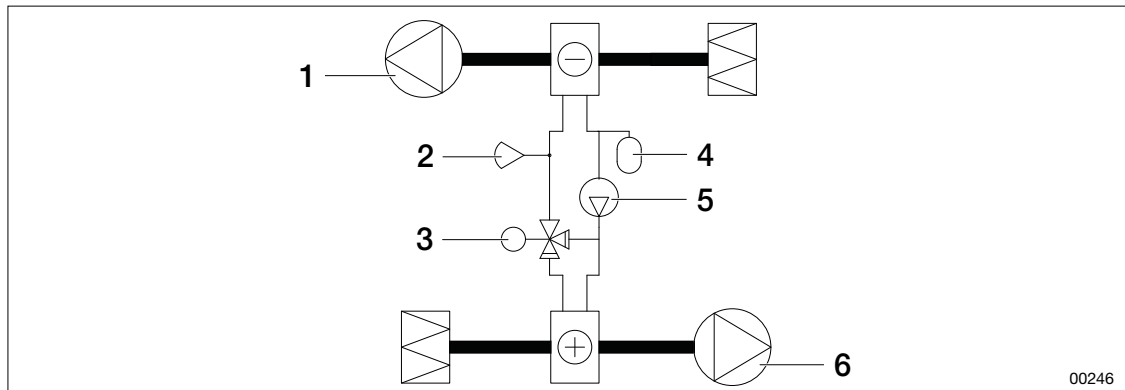

Figure: Coil recovery function diagram

- | | |
|--------------------------|--|
| 1. Extract air fan (EA) | 4. Expansion vessel (EXP) |
| 2. Freezing sensor (GT9) | 5. Circulation pump recovery circuit (CP3) |
| 3. Valve actuator (SV3) | 6. Supply air fan (SA) |

1. Manually set control signal to 100% open and visually confirm valve opening.
2. Manually set the control signal to 0% open and visually confirm that the valve is closed.
3. Reset from manual to automatic control.



Operation and maintenance

Envistar Flex

5.14 Maintenance of air heater/air cooler water

	WARNING! Risk of burns.
	<p><i>The parts, pipes and components of the unit may be hot during and after operation of the unit.</i></p> <ul style="list-style-type: none">• When the unit is in operation, inspection hatches must be closed and locked.• During service or other interventions, the unit must be switched off.• Inspection hatch for cooling unit/reversible heat pump: Wait at least 30 minutes after shutting down the unit before opening the compressor door.• Inspection hatch for heating coil: Wait at least 5 minutes after shutting down the unit before opening the door.

00184

Every 12 months and as needed

Ensure that the coil fins are clean and undamaged. If damaged, contact a service technician.

Make sure the coil is not leaking. In case of leakage, contact a service technician.

Visually confirm that drip tray and bottom plate are clean. Clean if necessary.

Ensure that the water trap (without non-return valve) is filled with water. See "[5.7 Maintenance of water trap](#)", page 19.

Ensure that the system pressure is the same as during installation. If necessary, add fluid to the system. See "[5.14.3 Bleeding the coil](#)", page 35.

Make sure the coils are bled. See "[5.14.3 Bleeding the coil](#)", page 35.

Ensure that the water flow is correct, according to Technical Data.

Thermoguard coils require additional maintenance. See "[5.14.4 Additional maintenance of Thermoguard coil](#)", page 35.

5.14.1 Clean the coils

1. Shut down the unit. See "[1.6 Safe shut-off of units](#)", page 8.
2. When the fans stop, open the inspection door.
3. From the inlet side: Gently vacuum with a soft vacuum nozzle.
4. From the outlet side: Gently clean with compressed air.
5. For heavy soiling, clean with hot water mixed with a dishwashing detergent that does not corrode aluminium.
6. Clean the interior of the unit cabinet. See "[5.6 Maintenance of unit cabinets and surfaces](#)", page 19.

5.14.2 Checking that the air heater regulates heating/cooling

Cooling is blocked when the outdoor temperature drops below the set value for cooling start.

1. Temporarily raise (for heat) or reduce (for cooling) the temperature setting (setpoint) to check that the coil is providing the intended temperature.

5.14.3 Bleeding the coil

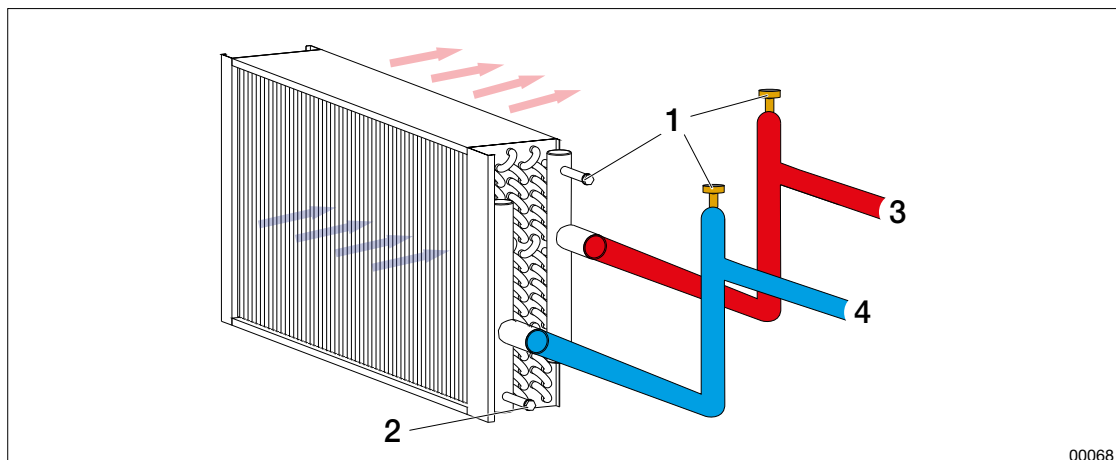

Figure: Bleeding and drainage

1. Nipple for bleeding
2. Nipple for drainage
3. Warm
4. Cold

1. Shut down the unit. See "[1.6 Safe shut-off of units](#)", page 8.
2. Prime the pipes by opening the bleeder screw/nipple in the pipe connection (top of the coil) and/or air vessel.

5.14.4 Additional maintenance of Thermoguard coil



CAUTION!

Risk of damage to Thermoguard air heater.

Start-up of a frozen air heater can severely damage or destroy the product.

- Ensure that the air heater is fully thawed before putting into operation

Every 12 months and as needed

Ensure that the pressure relief valve is not leaking. Flush or replace valve regularly, preferably more frequently than every 12 months. See "[Checking/cleaning the pressure relief valve](#)", page 35.

Make sure the coil is not frozen. See "[Defrosting frozen Thermoguard coil](#)", page 36.

Checking/cleaning the pressure relief valve

The pressure relief valve protects the coil from breaking during freezing. Shut-off valves on the supply or return lines must not be closed if freezing temperatures are likely.

A leaking valve may be due to impurities from the pipe system that have accumulated on the valve seat. If the leakage is not stopped after flushing, the pressure relief valve must be replaced with a valve of the same type and with the same opening pressure.

1. Flush the valve seat by gently turning the valve knob.
2. If leakage persists, replace the valve with one of the same type, with the same opening pressure.



Operation and maintenance

Envistar Flex

Defrosting frozen Thermoguard coil

- If the heat recovery unit is located:
- before the coil, run energy recovery until the coil defrosts.
- after the coil, use an external heat source to defrost the coil.

Before start-up, ensure that the coil, elbows, and pipes are completely defrosted. When the coil is fully defrosted, the fluid pressure drop at full liquid flow over the coil, must be consistent with the measured fluid pressure drop according to the adjustment procedure.

5.15 Maintenance of air heater electric

WARNING!

Risk of burns.

The parts, pipes and components of the unit may be hot during and after operation of the unit.



- When the unit is in operation, inspection hatches must be closed and locked.
- During service or other interventions, the unit must be switched off.
- Inspection hatch for cooling unit/reversible heat pump: Wait at least 30 minutes after shutting down the unit before opening the compressor door.
- Inspection hatch for heating coil: Wait at least 5 minutes after shutting down the unit before opening the door.

00184

Every 12 months and as needed

Visually confirm that the air heater is clean and undamaged. See "[5.15.1 Cleaning the air heater electric](#)", [page 36](#). If damaged, contact a service technician.

Make sure that the overheat protection works. If the overheat protection has tripped, the cause must be determined and corrected before the system is re-started. See "[5.15.2 Checking the overheat protection](#)", [page 36](#).

Visually confirm that the air heater is attached to the suspension and not deformed. If damaged, contact a service technician.

5.15.1 Cleaning the air heater electric

1. Shut down the unit. See "[1.6 Safe shut-off of units](#)", [page 8](#).
2. When the fans stop, open the inspection door.
3. Gently vacuum with a soft vacuum nozzle.
4. Wipe with a dry cloth.
5. Clean the interior of the unit cabinet. See "[5.6 Maintenance of unit cabinets and surfaces](#)", [page 19](#).

5.15.2 Checking the overheat protection



The risk of overheating increases as the air flow through the unit decreases. The air speed should not be lower than 1.5 m/s.

The overheat protection is located on the air heater side, on the cover panel. It triggers at around 120 °C. The air heater is equipped with double temperature delimiters. The one that resets itself automatically must be set to 70 °C.

1. Simulate a reduced power requirement by lowering the temperature setting (setpoint) so that all electrical steps (contractors) are OFF.
2. Greatly increase the setpoint and check that the electrical steps are ON.
3. Reset the setpoint.
4. Stop the unit without cutting power via the safety switch. All electrical steps (contractors) will turn OFF. Please note that the unit stop may be delayed approximately 2-5 minutes to cool down the air heater.

Manually resetting the overheat protection

If the unit triggers an alarm for electric heater failure, press the electric heater reset button and listen for clicking sounds.

5.16 Maintenance of damper and filter bypass

Every 12 months and as needed
Visually confirm that the damper is clean and undamaged. See "5.16.1 Cleaning the damper and filter bypass", page 37.
Visually confirm that the damper opens and closes properly. If not, contact a service technician.
Visually confirm that the damper seals when closed. Adjust actuator (not at trim damper). Make sure no there are screws through the drive mechanism/damper blades.
Make sure that the trim damper for the thermal wheel purging function works. See "5.16.2 Checking/adjusting the damper", page 37. For faults, contact a service technician.
Ensure gaskets are undamaged and seal. Replace damaged gaskets. See "5.16.3 Checking the gaskets", page 37.



Faulty shut-off damper function may result in increased fire hazard.

5.16.1 Cleaning the damper and filter bypass

1. Shut down the unit. See ["1.6 Safe shut-off of units", page 8.](#)
2. When the fans stop, open the inspection door.
3. Gently vacuum with a soft vacuum nozzle.
4. Wipe with a wet cloth. Use warm water and mild (non-corrosive) detergent.
5. For heavy soiling, use an environmentally friendly degreasing agent. Follow the instructions on the packaging.

5.16.2 Checking/adjusting the damper

Adjusting the damper motor

Make sure the damper closes and opens fully. If not, adjust the damper motor on the damper shaft.

Checking/adjusting trim damper for thermal wheel purging function

If the trim damper for the thermal wheel purging function is not working or is incorrectly set, it may result in odours from the extract air being transferred to the supply air via the thermal wheel. Make sure that the damper closes and opens correctly and that it is correctly set.

5.16.3 Checking the gaskets

1. Feel the gasket with your hands and make sure it has no dents or damage.
2. Check and ensure that the gasket closes tightly with no play.



5.17 Maintenance of intake section, exhaust air section, recirculating unit

Follow the damper inspection and maintenance points, see "[5.16 Maintenance of damper and filter bypass](#)", [page 37](#). If the exhaust air section part has drainage, check the water trap.

5.18 Maintenance of sound attenuator

Every 12 months and as needed

Visually confirm that the surfaces of the baffle elements are clean and undamaged. See "[5.18.1 Cleaning the extendible baffle](#)", [page 38](#).

5.18.1 Cleaning the extendible baffle

1. Shut down the unit. See "[1.6 Safe shut-off of units](#)", [page 8](#).
2. When the fans stop, open the inspection door.
3. Pull out the baffle.
4. Gently vacuum with a soft vacuum nozzle.
5. Wipe with a wet cloth. Use warm water and mild (non-corrosive) detergent.
6. For heavy soiling, clean with rotating nylon brush.
7. Before replacing the baffle, clean the interior of the unit cabinet. See "[5.6 Maintenance of unit cabinets and surfaces](#)", [page 19](#).

5.19 Maintenance of humidifier

Typically, the unit is not equipped with humidifiers. For maintenance and cleaning of humidifiers, refer to the manufacturer's care instructions.

6 ALARM

This section applies to the MX control equipment.

6.1 Reset alarms after action



- In the event of an alarm, a **red light flashes** on the hand-held terminal.
- After taking action, reset alarms by following the instructions on the hand-held terminal label (located on the unit).

6.2 Fire alarm (fire damper, fire fan)



WARNING!

Risk of life-threatening or serious personal injury.

Added oxygen to the unit can spread the fire. The unit may be hot.

- If a fire is suspected in the unit:
 - Do not open the door.
 - Call emergency services.
- Use caution when touching the unit surfaces/doors.

00356

Alarm Display	Possible cause of error	Actions if incorrect
Fire alarm	Central fire alarm Smoke/fire in the unit, duct, or in the building.	If a fire is suspected, call emergency services.
Fire alarm temp Extract air / Supply air	> 40 °C in extract air or > 50 °C in supply air. Increased temperature due to hot water in heating water line or fire in unit/duct.	Make sure there is no fire. If there is no fire, but the duct detectors shine red, reset the detectors manually. Make sure that the air heaters are working properly.
Fire damper in wrong position	Fire damper open when it should be closed or vice versa.	Adjust fire damper.
Fire fan - no feedback	Pressure hoses incorrectly connected.	Make sure the pressure line is in the duct.
Fire damper feedback	Fire damper is in incorrect position.	Adjust damper.

6.3 Alarm filter

Alarm name on display	Possible cause of error	Actions if incorrect
Filter alarm, fire	Clogged filters or smoke /fire in filters.	Make sure there is no fire. See " 6.2 Fire alarm (fire damper, fire fan) ", page 39 and " 5.8 Maintenance of filters ", page 20.
Filter alarm	Clogged or incorrectly installed filters.	See " 5.8 Maintenance of filters ", page 20.



Operation and maintenance Envistar Flex

6.4 Temperature/cooling/freeze protection alarm

Alarm Display	Possible cause of error	Actions if incorrect
Freeze protection alarm	Incorrect function in: <ul style="list-style-type: none"> • circulation pump • heat exchangers • heating valve/actuator 	Check alarms on the circulation pump display. See "5.9 Maintenance of rotary heat exchanger", page 22 or "5.11 Maintenance of the plate heat exchanger", page 29.
	Non-continuous water flow through the coil due to air in coils, leakage or freezing.	Make sure that the hot water pipes are hot. See "5.14 Maintenance of air heater/air cooler water", page 34 and "5.15 Maintenance of air heater electric", page 36.
Alarm cooling	Cooling circuit error.	See separate Operation and Maintenance instructions for the cooling unit.
Temp deviations	Incorrect function in: <ul style="list-style-type: none"> • heat exchangers • additional heating coil (internal or external) • cooling unit. 	See "5.9 Maintenance of rotary heat exchanger", page 22 and "5.11 Maintenance of the plate heat exchanger", page 29. See "5.14 Maintenance of air heater/air cooler water", page 34 and "5.15 Maintenance of air heater electric", page 36. See separate Operation and Maintenance instructions for the cooling unit.
	Incorrectly set temperature values.	Adjust the set values.
Tempdiff. heating	Unexpected temperature difference: supply air sensor (GT1)/ supply air sensor energy recovery (GT6).	Ensure that the heating valve is not leaking or is manually set to the open position.

6.5 Other alarms

Alarm Display	Possible cause of error	Actions if incorrect
Modbus alarm	Quick connectors incorrectly connected.	Connect quick connectors.
Communication _damper _sensor module _air supply fan _extract air fan _heat recovery	No communication between Climatix and modbus connected device.	Connect quick connectors between unit parts.
Sensors _Not inc. _-252 °C	Sensor defective or incorrectly connected.	Ensure correct function. Replace faulty sensor.
Not config. IO	Configuration incorrectly completed (saved).	Exit and save configuration.

7 TROUBLESHOOTING

Area	Wrong	Reason	Corrective action
Residual current circuit breaker Fuses Electricity	No unit power.	Tripped residual current circuit breaker/fuse. Supply not connected.	Ensure connected supply and installed residual current circuit breaker (300 mA). Ensure fuses are on and properly installed for rated current. Troubleshoot by turning all fuses off and on one at a time. If fuse or residual current circuit breaker trip, contact a licenced electrician.
	Black display.	Display not connected. Voltage supply not functioning.	Make sure the cable is connected.
Water Drain Drainage	Water not draining from drip drums.	Water trap incorrectly installed or clogged. Unit incorrectly positioned.	Ensure that the unit has the correct tilt on the inspection side. See Assembly Instructions for the unit and "5.7 Maintenance of water trap", page 19.
Energy use Heat transfer Air flow	Insufficient efficiency.	Incorrect function in: <ul style="list-style-type: none"> • rotary heat exchanger • plate heat exchanger • coil recovery and air heater/air cooler. 	See "5.9 Maintenance of rotary heat exchanger", page 22 or "5.11 Maintenance of the plate heat exchanger", page 29 or "5.13 Maintenance of run-around coil unit", page 32 or "5.14 Maintenance of air heater/air cooler water", page 34 or "5.15 Maintenance of air heater electric", page 36.
	Reduced air flow.	Incorrect rotation direction of fan impeller. Pressure drop too high in the duct system.	Ensure correct rotation direction and that the flow measurement ring line and connected hoses are undamaged. See "5.12 Maintenance of fan", page 30 or "5.16 Maintenance of damper and filter bypass", page 37.
Odour transfer	Odour transfer between extract air and supply air.	Leakage between extract air and supply air (duct system, intake and exhaust hood, damper or louvre).	See "5.9 Maintenance of rotary heat exchanger", page 22 , "5.11 Maintenance of the plate heat exchanger", page 29 and "5.16 Maintenance of damper and filter bypass", page 37.
Frost build-up Ice build-up	Frost or ice build-up on the heat recovery coil extract air.	The frost protection equipment not functioning correctly.	Contact service personnel for freeze protection sensor setting, function of the three-way valve and pump.
	Freezing in plate heat exchangers.	Abnormally high moisture content in the extract air.	See "5.11.2 Checking damper for defrosting function (ODS)", page 29 or "5.11.3 Checking damper for freeze protection (BYP)", page 30.
Overheating electric heater	Overheat protection tripped.	The electric heater is heavily soiled.	Clean and reset. See "5.15 Maintenance of air heater electric", page 36.



8 DECOMMISSIONING AND RECYCLING



WARNING!

Risk of cutting.

Sharp edges can cause cuts.

- Use appropriate personal protective equipment when the work requires it.

00181



WARNING!

Risk of serious personal injury.

Contact with refrigerants can cause frostbite to the skin.

- Refrigerants and parts containing refrigerants may only be handled by persons with certificates in accordance with current EU regulations for refrigerants.
- Wear appropriate protective clothing.

00331



WARNING!

Risk of personal injury.

Contact with the oil can cause skin irritations.

- Draining oil from the compressor must only be carried out by certified persons in accordance with applicable EU regulations for refrigerants.
- Wear appropriate protective clothing.
- Wash hands and other body parts that have been in contact with the oil.

00330



WARNING!

Risk of inhalation of harmful particles.

When changing filters, particles, such as dust, may come loose from the used filter.

- Wear a protective mask when changing filters.
- Use caution when handling used filters.
- Thoroughly clean the filter cabinet after replacement as particulate matter may become loose and remain in the cabinet.

00325

8.1 Disposal and recycling.

Disposal and recycling must be carried out in an environmentally safe manner according to current regulations in the country where the product is being decommissioned. Up to 90% of the material in the unit can be recycled.

8.2 Before disassembly



- Cooling unit/reversible heat pump and DX coils must be emptied of refrigerant by a certified cooling technician before disassembly. See separate Operation and Maintenance instructions for ThermoCooler HP and EcoCooler.
- Air heaters and air coolers must be drained of fluid (for example, glycol) before disassembly.
- Liquids may contain additives or contaminants and must be handled in accordance with applicable national and international environmental requirements.

8.3 Dismantling the unit

1. Switch off all electricity and make sure there is no power to the unit. See "[1.6 Safe shut-off of units](#)", [page 8](#).
2. Remove covers, electrical components and filters.
3. Knock apart profiles and joins.
4. Split the covers and remove internal insulation.
5. Sort and recycle in accordance with applicable national regulations in the country where the unit is decommissioned.

8.4 Material content

For more specific information about materials, see the Building Product Declaration under Documentation on ivprodukt.docfactory.com or contact IV Produkt.

9 SERVICE SCHEDULE

For descriptions of different unit parts and their functions, refer to Functional Descriptions in Section "3 DESCRIPTION OF THE UNIT", page 12.

Service year:		Order no:	Project name:			
Notes:			Service performed (date/signature)			
Unit part	Code	Check: (refer to Instructions For Use in the sections below)	12 months	24 months	36 months	48 months
Filter	ELEF	<i>"5.8 Maintenance of filters", page 20</i>				
Rotary heat exchanger	EXR	<i>"5.9 Maintenance of rotary heat exchanger", page 22</i>				
Plate heat exchanger Counter-flow heat exchanger	EXP EXM	<i>"5.11 Maintenance of the plate heat exchanger", page 29</i>				
Fan	ELFF	<i>"5.12 Maintenance of fan", page 30</i>				
Run-around coil unit	EXL	<i>"5.13 Maintenance of run-around coil unit", page 32</i>				
Air heater water	EMT-VV MIE-CL/ELEV ESET-TV MIE-CL/ELTV	<i>"5.14 Maintenance of air heater/air cooler water", page 34</i>				
Air cooler water	ESET-VK MIE-CL/ELBC MIE-CL/ELBD	<i>"5.14 Maintenance of air heater/air cooler water", page 34</i>				
Air heater electric	ESET-EV MIE-EL/ELEE	<i>"5.15 Maintenance of air heater electric", page 36</i>				
Damper	EMT-0, ESET-TR	<i>"5.16 Maintenance of damper and filter bypass", page 37</i>				
Outdoor intake section with damper	MIE-IU	<i>"5.17 Maintenance of intake section, exhaust air section, recirculating unit", page 38</i>				
Outdoor exhaust air section with damper	EAU	<i>"5.17 Maintenance of intake section, exhaust air section, recirculating unit", page 38</i>				
Recirculating unit section with damper	EBE	<i>"5.17 Maintenance of intake section, exhaust air section, recirculating unit", page 38</i>				
Noise attenuator	EMT-02 MIE-KL	<i>"5.18 Maintenance of sound attenuator", page 38</i>				
Humidifier		<i>"5.19 Maintenance of humidifier", page 38</i>				
Filter bypass	ENFT-10	<i>"5.16 Maintenance of damper and filter bypass", page 37</i>				
Reversible heat pump	TCH TCR	See separate Operation and Maintenance instructions for Thermocooler HP				
Cooling unit	ECO ECX	See separate Operation and Maintenance instructions for EcoCooler				

Operation and maintenance Envistar Flex





Order Portal

Operation and maintenance Envistar Flex

Operation and maintenance Envistar Flex



You are welcome to contact us



IV Produkt AB, Sjöuddevägen 7, S-350 43 Växjö, Sweden
+46 470 – 75 88 00
www.ivprodukt.se, www.ivprodukt.com
www.ivprodukt.no, www.ivprodukt.dk, www.ivprodukt.de



Support:

Control: +46 470 75 89 00, styr@ivprodukt.se
Service: +46 470 75 89 99, service@ivprodukt.se
Spare parts: +46 470 75 86 00, reservdelar@ivprodukt.se
DU/Documentation: +46 470 75 88 00, du@ivprodukt.se

For support, enter the Order Number.

Order number:

Project name:
