



Operation and maintenance

Envistar Top

Size 04-28



Order number:

Project name:





Documentation for your unit

1. Scan QR code or enter orderdocs.ivprodukt.com in your web browser.
2. Enter your order number.
3. Press ENTER or click search.
4. Select your order.

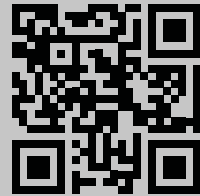

Is documentation missing?

See information in section
"2.1 Documentation and Support" page 2.

Unit specification

Unit type

TEM	TXM		TEXM
TER	TXR		TEXR
TEC-R		1V	2V
TECO		1V	2V
TECX		1V	2V
TTCH		1V	2V
TEC-M			
TTC			

Home Concept configuration

Unit parts and accessories

Rotary heat exchanger TXRR

Counter-flow exchanger TXMM

Air heater water ETAB-VV

Power variant 1 2 3

Air heater water SBK-VV

ThermoGuard ETAB-TV

Power variant 1 2

Air heater electric ETAB-EV

Power variant 1 2 3

Air heater electric ETKB-EV

Power variant 1 2 3 4

Air heater electric ETAB-SV

Air cooler water ETKB-VK

Air cooler water SBK-VK

Damper ETSP-UM, ETSP-TR, ETRL

Sound attenuator ETLD

Size

04	06	09	10
12	17	22	28

Control equipment

MX

UC

MK

US

HS

For filter class and size, see Technical data for the unit on IV Produkt's order portal.

Operation and maintenance

Envistar Top

TABLE OF CONTENTS

1	SAFETY	7
1.1	Intended application	7
1.2	Unintended use	7
1.3	General safety	7
1.4	Structure of warning messages	8
1.5	General warning notices	8
1.6	Safe shutdown of the unit	8
1.7	Signs on the unit	8
1.7.1	Type plate.....	8
1.8	Accidents and incidents	9
1.9	Product liability	9
1.10	Noise	10
1.11	Handling of refrigerant	10
1.12	After the product's lifetime	10
2	GENERAL INFORMATION	11
2.1	Documentation and support	11
2.2	Informational message, not safety-related	11
2.3	Spare parts	11
2.4	Terms and abbreviations in the manual	11
2.5	Symbols on dimension drawings (technical data)	12
3	DESCRIPTION OF UNIT	13
3.1	Unit design.....	13
3.2	Orientation of the unit sides/parts	13
3.3	Signs on the unit	13
3.4	Basic functions.....	14
3.4.1	Filter	14
3.4.2	FLC - Automatic filter control.....	14
3.4.3	Fan	14
3.4.4	Air heater electric	15
3.4.5	Air heater/air cooler water.....	16
3.4.6	Damper	16
3.5	Heat exchanger	16
3.5.1	Rotary heat exchanger - Home Concept	16
3.5.2	Counter-flow heat exchanger - Defrost/freezing.....	16

Operation and maintenance Envistar Top



3.6	Optional extras	16
3.6.1	Recirculating unit with shut-off/control damper (option)	16
3.6.2	EcoCooler cooling unit (option).....	16
3.6.3	Reversible heat pump ThermoCooler (option)	17
3.6.4	Heating mode.....	17
3.7	Refrigerant detector system	18
4	COMMISSIONING AND OPERATION.....	19
4.1	Switch off the unit for service.....	19
4.2	Before commissioning.....	20
4.3	Status information	20
4.3.1	Detection system	20
4.3.2	Cooling unit 04-12	21
4.3.3	Cooling unit 17-22	23
4.3.4	Reversible heat pump	24
5	MAINTENANCE	26
5.1	Maintenance intervals	26
5.2	Hygiene inspection VDI 6022 (optional extra).....	26
5.3	Downtime.....	26
5.4	Switch off the unit before maintenance.....	26
5.5	Starting the unit after maintenance	28
5.6	Maintain unit cabinets and surfaces.....	28
5.7	Water trap maintenance	28
5.8	Filter maintenance	29
5.8.1	Replacing disposable bag filter or carbon filter	29
5.8.2	Cleaning the aluminium filter.....	30
5.8.3	Check pressure drop across filter	30
5.9	Maintenance of rotary heat exchanger.....	31
5.9.1	Cleaning the rotary heat exchanger	31
5.9.2	Replacing the brush strip.....	32
5.9.3	Replacing or shortening the drive belt	33
5.9.4	Check pressure balance/leakage direction - Home Concept (with automatic pressure balance control)	34
5.9.5	Check the pressure balance in the AHU (air handling unit) with manual trim damper ..	35
5.9.6	Check differential pressure across rotary heat exchangers.....	36
5.9.7	Adjusting the purging sector.....	37
5.9.8	Purging sector - setting values	37
5.10	Maintenance of counter-flow heat exchangers	38
5.10.1	Cleaning heat exchangers.....	38
5.10.2	Checks	39
5.11	Fan maintenance	40
5.11.1	Clean the fan and motor	40
5.11.2	Checks	40

Operation and maintenance

Envistar Top

5.12	Maintenance of air heater/air cooler water	42
5.12.1	Clean air heater/air cooler water	42
5.12.2	Check that air heater/air cooler water regulates heating/cooling	42
5.12.3	Aerate air heater/air cooler water	43
5.12.4	Additional maintenance Thermoguard air heater	43
5.13	Maintenance of air heater electric	44
5.13.1	Cleaning the air heater electric	44
5.13.2	Checking the overheat protection.....	44
5.14	Maintenance of refrigerant circuit	45
5.14.1	Checks/record keeping, according to the European F-gas Regulation.....	45
5.14.2	Registry administration of events/inspections	45
5.14.3	Use and inspection of pressurised equipment	45
5.14.4	Country-specific requirements and laws	45
5.14.5	Refrigerant detector system.....	45
5.15	Damper maintenance	45
5.15.1	Clean dampers.....	46
5.15.2	Control	46
5.16	Sound attenuator maintenance	46
6	ALARM	47
6.1	Reset the alarm.	47
6.1.1	Alarm reset - High-pressure switch tripped	47
6.1.2	Alarm reset - Alarm from the inverter or compressor	47
6.2	Alarm Control system AHU (air handling unit)	48
6.3	Alarm Control system cooling unit/heat pump	49
6.4	Fire alarm (fire damper, fire fan)	51
6.5	Alarm filter	51
6.6	Temperature/cooling/freeze protection alarm	52
6.7	Other alarms	52
7	TROUBLESHOOTING	53
8	DECOMMISSIONING AND RECYCLING	54
8.1	Disposal and recycling	54
8.2	Dismantling the AHU (air handling unit).....	55
8.3	Material content	55
9	SERVICE SCHEDULE	56

1 SAFETY

This section addresses important safety aspects during operation and maintenance, with the aim of increasing safety awareness and avoiding injury to people or damage to the environment and the unit.

For units in vulnerable environments, servicing and maintenance are essential for maximum service life and maintained warranty. Follow the applicable operating and care instructions for each unit part in this document. See separate Operation and maintenance for EcoCooler cooling unit and ThermoCooler HP reversible heat pump.



- This manual contains important instructions. Read it carefully and follow the instructions.
- Pay special attention to warning and information messages, as well as markings on the product.
- Keep the manual for future use.

00177

1.1 Intended application

Intended use

The unit is intended for use as an air handling unit for comfort ventilation in buildings.

Intended users

The contents of this manual are intended for personnel with the knowledge necessary to commission and operate the AHU (air handling unit) and carry out ongoing maintenance. Maintenance and servicing of the cooling unit/reversible heat pump must be carried out by a certified refrigeration technician.

Intended use environment

- The AHU (air handling unit) is usually placed indoors.
- When installed indoors, the unit should be placed in a ventilated space that maintains a temperature of +7 – +30 °C and, during winter, a humidity level of < 3.5 g/kg dry air.
- The unit can also be equipped for assembly in cold attics.

1.2 Unintended use

Only uses specified in Intended Use are permitted. The unit must not be used in potentially explosive environments.

1.3 General safety

Failure to comply with the safety precautions may result in injury to persons or damage to air handling units. To avoid injury to persons, or damage to surroundings or equipment:

- Follow national and local laws/regulations for safe work, e.g. fall protection when working at a height.
- Do not wear loose-fitting clothing or jewellery that could get caught.
- Do not step or climb on the unit.
- Use appropriate tools.
- Use appropriate personal protective equipment.
- Note the unit's markings, product signs, information labels and warning stickers.
- Ensure that all doors are in place and closed during operation.

Personal protective equipment

Personal protective equipment should always be used based on the risks that occur in the workplace. For example, wear protective footwear with steel toecaps, hearing protection, safety helmet, gloves, safety eyewear or goggles, fully-covering clothing, safety overalls, face mask/protective mask and/or fall protection where the work and work environment require it.



Operation and maintenance Envistar Top

1.4 Structure of warning messages

Warning messages in the instructions warn of risks when handling and assembling the product. Carefully follow the instructions in the warning messages.



The warning symbol indicates that a risk exists.

WARNING! indicates a potential hazard which, if not avoided, could result in death or **serious** injury.

CAUTION! indicates a potential hazard which, if not avoided, could result in **material damage** to the product or its surroundings, as well as impaired product function.

"**Risk for xxxxxx.**" indicates the risk in a short risk title.

Descriptions in italics provide more detailed information about what the risk entails.

- The points indicate how the user can avoid harm.

1.5 General warning notices

See warnings in section "*5 MAINTENANCE*", page 26.

1.6 Safe shutdown of the unit

Before and during maintenance and service, follow instructions and read warnings in section "*5.4 Switch off the unit before maintenance.*", page 26.

1.7 Signs on the unit

Keep signs and decals clean from dirt. Replace missing, damaged or illegible signs and decals on the machine. Contact IV Produkt for replacement stickers.

1.7.1 Type plate

The unit and any associated cooling unit/reversible heat pump have a type plate affixed to the front. The type plate is used to identify the product.

Air handling unit

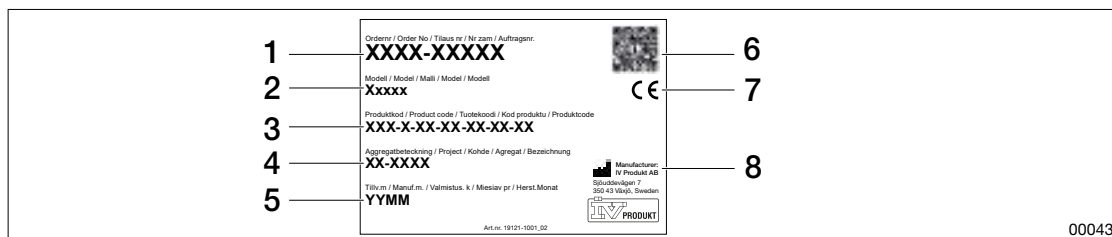

Figure: Example image: Unit type plate

- | | |
|-----------------------|------------------------|
| 1. Order number | 5. Date of manufacture |
| 2. Product name/model | 6. QR code |
| 3. Product code | 7. CE mark |
| 4. AHU designation | 8. Manufacturer |

Cooling/heating units (ThermoCooler HP/EcoCooler)

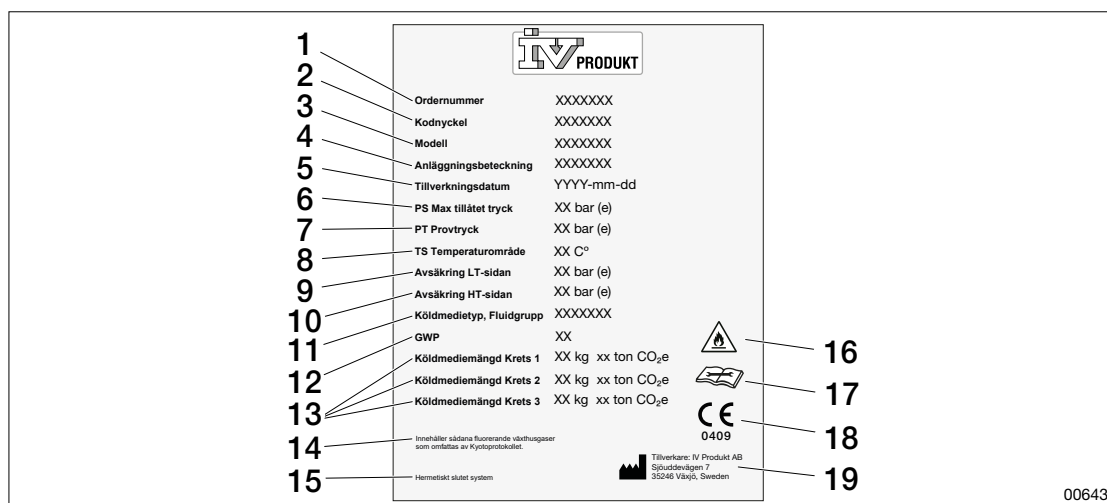

Figure: Type plate for cooling/heating units

- | | |
|--|---|
| 1. Order number | 12. GWP |
| 2. Code key (AHU (air handling unit) type) | 13. Refrigerant volume, Circuit 1/2/3, kg, CO ₂ e |
| 3. Model | 14. Contains fluorinated greenhouse gases controlled by the Kyoto Protocol. |
| 4. Facility designation | 15. Hermetically sealed system. NB! Not available at Easy Access. |
| 5. Date of manufacture | 16. Contains mildly flammable substance |
| 6. PS Max allowed pressure, bar (e) | 17. Read service manual |
| 7. PT Pressure test, bar (e) | 18. CE marking, Notified body |
| 8. TS Temperature range, °C | 19. Manufacturer |
| 9. Fuse LT side, bar (e) | |
| 10. Fuse HT side, bar (e) | |
| 11. Refrigerant type, Fluid Group | |

1.8 Accidents and incidents

Report accidents and incidents according to national and local laws/regulations.

1.9 Product liability

The unit complies with industry requirements for quiet air handling units with high-efficiency recovery systems for heating and cooling.

CE marking

The air handling unit is CE marked and meets the requirements according to specified directives and standards in the Declaration of Conformity. The marking covers the unit in the version in which it was delivered and provided that it has been assembled and put into operation according to IV Produkt's instructions. This does not cover units that have been modified, components that have been added later, or other systems in which the unit may be included. The unit may not be put into use until the system in which it is part complies with the requirements for CE marking.

The Declaration of Conformity can be downloaded from IV Produkt's order portal. See "[Documentation for your unit](#)", page 2.

Manufacturer

The air handling unit is manufactured by IV Produkt AB, Sjöuddevägen 7, S-350 43 VÄXJÖ.



Operation and maintenance

Envistar Top

Guarantee

For proper function and for the warranty to be valid, IV Produkt's assembly instructions must be followed.

Extended warranty

Extended warranty is additional to the order and in order to claim the extended warranty (5 years) a complete documented and signed IV Produkt Service and Warranty Book must be presented, according to ABM 07 with supplement ABM-V07 or according to NL 17 with supplement VU 20.

Disclaimer

Ongoing product development may result in changes without prior notice.

1.10 Noise

	<p>WARNING! Risk of personal injury due to high noise levels. <i>High noise levels can cause damage to hearing.</i></p> <ul style="list-style-type: none">• Check the noise level in the current operation point. See information in Technical Data for the unit in question.• Comply with local and national regulations for work at higher noise levels.	00259
--	---	-------

Hearing protection is recommended for extended work in noisy environments, such as plant rooms.

1.11 Handling of refrigerant

This document summarises the requirements and guidelines of the European F-Gas Regulation. For further information, please refer to national requirements for handling of refrigerant

Leakage control and registration

Leakage control and registration must be carried out in accordance with national, applicable regulations.

1.12 After the product's lifetime

For dismantling and decommissioning, see "[8 DECOMMISSIONING AND RECYCLING](#)", page [54](#).

2 GENERAL INFORMATION

2.1 Documentation and support

The documentation for your unit can be found in the Order Portal. See "[Documentation for your unit](#)", page 2.

It can take up to two weeks for all documentation to be available in the Order Portal. The text "Documentation in progress" is displayed until the documentation is complete. If documentation is missing or incorrect, please contact DU/Documentation. For other support, contact the department to which the case applies. See contact information on the back of the manual.

2.2 Informational message, not safety-related



Symbol together with information text highlights difficulties and also gives tips and recommendations.

00182

2.3 Spare parts

Spare parts list can be found in the Order Portal. Order spare parts and accessories from IV Produkt. See contact information on the back of the manual. Please state the order number and AHU designation from the type plate, located on the unit.

2.4 Terms and abbreviations in the manual

Term	Explanation
Thermal wheel	Rotary heat exchanger
Unit part	Part of the unit. May contain function (for example fan, media etc) but may also be an empty part.



Operation and maintenance Envistar Top

Order portal

2.5 Symbols on dimension drawings (technical data)

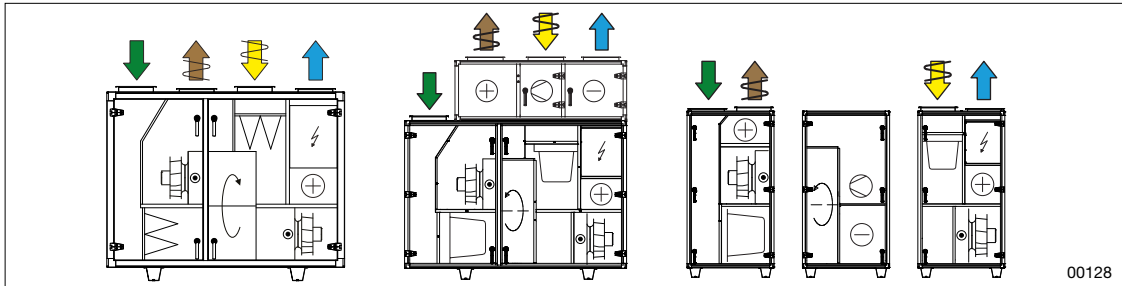

Figure: Example installation drawing

	Outdoor air		Extract air
	Supply air		Exhaust air
	Fan		Filter
	Shut-off damper		Trim damper
	Air cooler water		Air heater water
	Air heater electric		Sound attenuator
	Rotary heat exchanger		Counterflow heat exchanger
	Cooling unit		Reversible heat pump
	Compressor		Media section/Control cabinet
	Quick contact		

3 DESCRIPTION OF UNIT

3.1 Unit design

The AHU (air handling unit) is available in different sizes 04-28, in right-hand or left-hand configurations and with different functional components. The framework of the units consists of aluminium profiles.

3.2 Orientation of the unit sides/parts

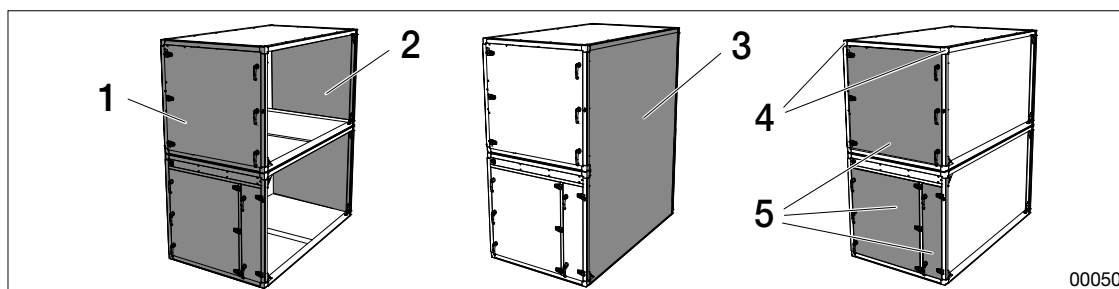



















Figure: Parts of the unit

- | | |
|--|--|
| <ul style="list-style-type: none"> 1. Access side 2. Back 3. Gable side | <ul style="list-style-type: none"> 4. Assemble cover detail on joint 5. Covers |
|--|--|

3.3 Signs on the unit

	Filter		Air turner
	Rotary heat exchanger		Flue gas bypass from above
	Fan		Flue gas bypass from the side
	Air cooler water		Media
	Air heater liquid		Empty
	Air heater electric		Angle
	Damper		Earth
	Sound attenuator		Inspection
	Temperature sensors		



Operation and maintenance

Envistar Top

3.4 Basic functions

More information can be found in the section "[5 MAINTENANCE](#)", page 26.

3.4.1 Filter

Different filters have different dirt accumulation capacities. When replacing them, filters of the same quality and capacity of those originally supplied must be used. Refer to the Technical Data document or the Spare Parts list.

Bag filter: The bag filters are designed as single use. Used filters must be disposed of in accordance with applicable environmental regulations.

Aluminium filter: Aluminium woven flat filter, used for extract air containing grease particles. Cleanable.

3.4.2 FLC - Automatic filter control

In units with automatic filter control FLC, the filter alarm is triggered if a filter needs to be replaced.

Reset the filter control function on the hand-held terminal display before starting the AHU (air handling unit). For more information, see separate control documentation for Climatix.

3.4.3 Fan

The radial fans are wall-mounted (size 04/06) or mounted on rails fitted with vibration dampers.

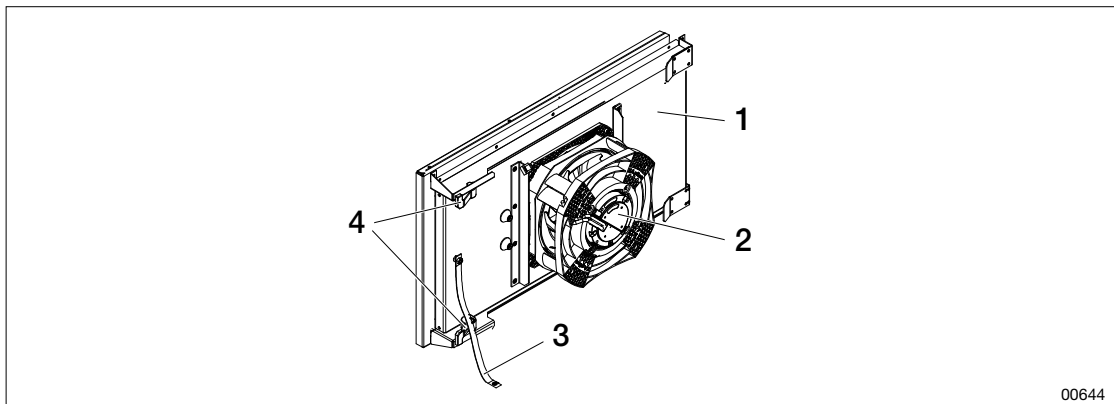

Figure: Example fan unit size 04 with fan impeller 020

- | | |
|----------------------------|-------------------|
| 1. Mounting plate fan | 3. Earthing braid |
| 2. Fan impeller with motor | 4. Snap lock |

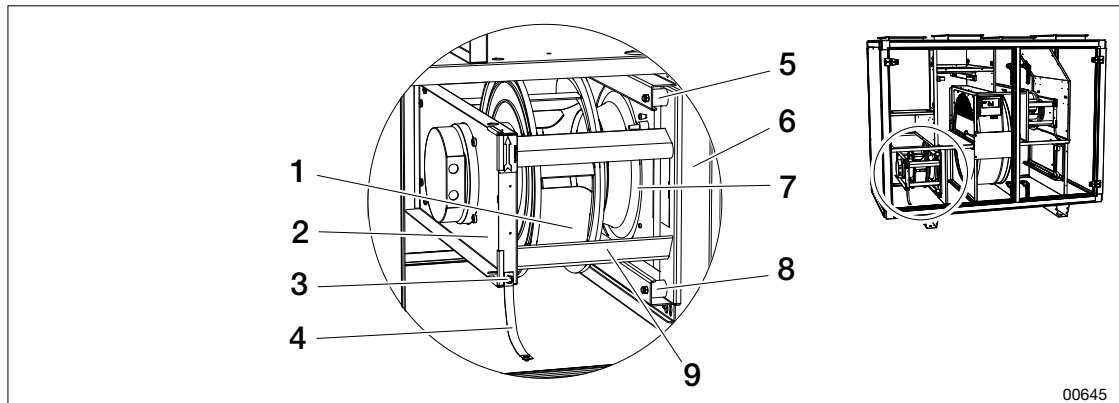

Figure: Example fan unit Wall mounted, size 04-06 with impeller 025

- | | |
|----------------------------|---------------------------|
| 1. Fan impeller with motor | 6. Connection plate |
| 2. Mounting plate fan | 7. Inlet cone |
| 3. Edge cover | 8. Vibration damper |
| 4. Earthing braid | 9. Anti-vibration support |
| 5. Screws suspension | |

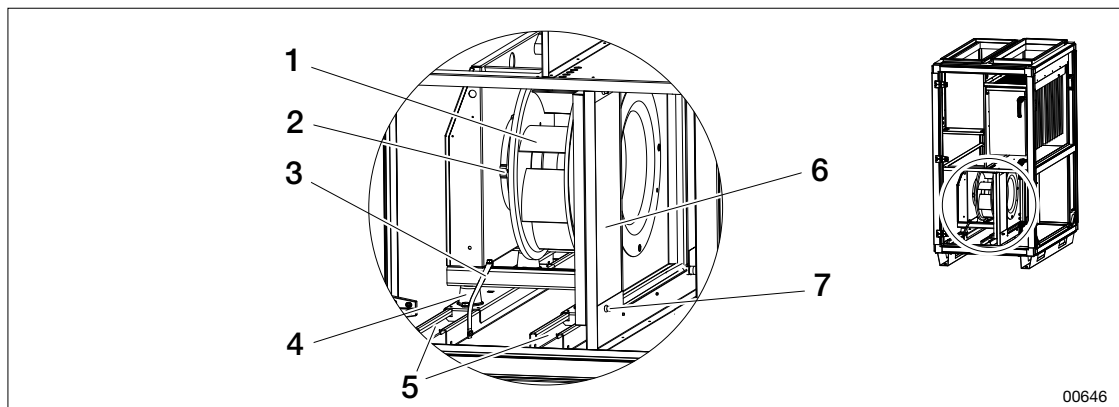

Figure: Example fan unit mounted on rails, size 09-28

- | | |
|---------------------|----------------------|
| 1. Fan impeller | 5. Rails |
| 2. Motor | 6. Side cover |
| 3. Earthing braid | 7. Screws side cover |
| 4. Vibration damper | |

3.4.4 Air heater electric

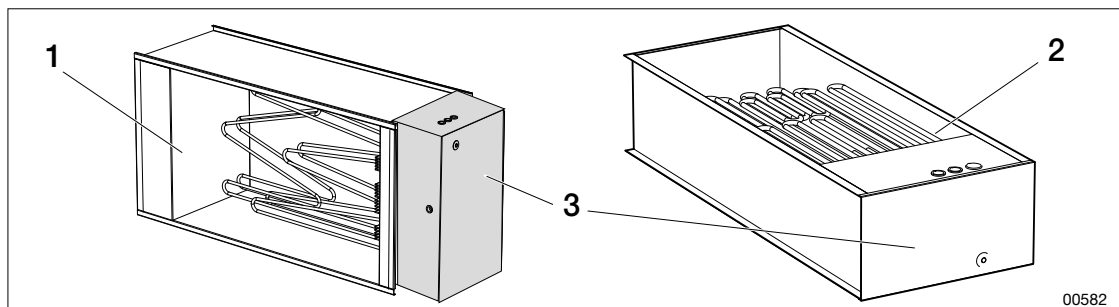

Figure: Air heater

- | | |
|--|-------------------|
| 1. Air heater electric (ETKB-EV) for duct mounting | 3. Connection box |
| 2. Air heater electric (ETAB-EV) for unit mounting | |



Operation and maintenance

Envistar Top

3.4.5 Air heater/air cooler water



CAUTION!

Risk of damage to Thermoguard air heater.

Start-up of a frozen air heater can severely damage or destroy the product.

- Ensure that the air heater is fully thawed before putting into operation again.

00354

Thermoguard air heater

The air heater safety valve prevents the air heater from freezing. The safety valve must be installed by the customer and is not included in the product on delivery.

3.4.6 Damper

Dampers, such as shut-off/control dampers and trim dampers with manual control, may be placed at different locations in the system.

3.5 Heat exchanger

3.5.1 Rotary heat exchanger - Home Concept

Units in the Home Concept configuration are equipped with a function to control the pressure balance to ensure the correct leakage function and purging function. The trim damper automatically regulates the pressure balance according to the set value in the control unit. For units supplied with MX control equipment, the function is connected at the factory. In units delivered without control equipment, the function must be connected by the customer. The purging sector is set to its maximum open value upon delivery.

3.5.2 Counter-flow heat exchanger - Defrost/freezing

Defrost function ODS (TXMM-XP/NP)

The defrost function regulates the dampers to defrost the plate heat exchanger after ice formation. The program is pre-set upon delivery and may not be adjusted or modified without support from IV Produkt.

Anti-freeze BYP (TXMM-NP)

The freeze protection regulates the dampers on the outdoor air side of the plate heat exchanger to prevent freezing. For units with MX control equipment, the program is pre-set upon delivery and must not be adjusted or changed without support from IV Produkt. For units without control equipment (MK, US, UC), it must be programmed and integrated into external control equipment by the customer.

3.6 Optional extras

3.6.1 Recirculating unit with shut-off/control damper (option)

The recirculating unit with shut-off/control damper is used to recirculate air when heating premises at night and to modulate recirculating air.

3.6.2 EcoCooler cooling unit (option)

The integrated cooling unit with EcoCooler is available as an optional extra to an Envistar Top AHU (air handling unit) with a rotary heat exchanger or counter-flow exchanger.

The Envistar Top EcoCooler with R454B is equipped with integrated control equipment (code MX).

The AHU (air handling unit) has an electronic expansion valve and speed-controlled compressor.

3.6.3 Reversible heat pump ThermoCooler (option)

The integrated reversible heat pump ThermoCooler HP is available as an optional extra to an Envistar Top unit with a rotary heat exchanger. The units are intended to be used to cool or heat supply air in properties.

Envistar Top with ThermoCooler HP always comes with integrated control equipment (code MX).

The AHU (air handling unit) has an electronic expansion valve and speed-controlled compressor.

Compressor and compressor protection

The reversible heat pump is equipped with a speed-controlled PM scroll compressor. In some sizes, the reversible heat pump is equipped with an additional fixed compressor to achieve cooling or heating output. The control is variable.

The reversible heat pump is interlocked over the air handling unit, which means that if any of the fans stop, the reversible heat pump is stopped. It cannot be restarted until the minimum airflow rate is reached. The same applies if a heater is fitted. The interlock and demand signal is sent via Modbus. See "[6 ALARM](#)", [page 47](#).

Cooling mode

The condenser is normally located in the extract air, but can also be located in the exhaust air for additional cooling power.

- Supply air battery = evaporator (cooling coil)
- Extract air battery = condenser (heating coil)

3.6.4 Heating mode

The compressor will only start when the heat exchanger's energy recovery is insufficient to heat the supply air.

- Extract air battery = evaporator (cooling coil)
- Supply air battery = condenser (heating battery)



3.7 Refrigerant detector system

Reversible heat pump (size 09 and larger) and cooling unit (size 12 and larger) with refrigerant R454B, are equipped with detectors to detect refrigerant leakage as standard. For units with refrigerant R410A, the detector equipment is available as an option.

To ensure acceptable dilution in the event of a refrigerant leak, the air flow on both the supply and extract sides must exceed the AHU (air handling unit)'s specified minimum flow rate, see docs.ivprodukt.com (Technical data).

In the event of a refrigerant leak, the installed detector system ensures that the minimum permissible air flow is always achieved, which dilutes the refrigerant to an approved level.

For leak detection and ventilation to work effectively, the unit must have power and the service switch must remain in the 'Auto' position at all times after installation, except during work/servicing.

If the detector triggers a leak alarm, the unit's fans are started to dilute the refrigerant to an approved level, and an alarm notification is shown on the Climatix display.

Should a detector be non-functional, an alarm is triggered and the air handling unit is kept running until the fault is rectified.

In the event of an alarm, correct the fault and then reset the alarm.

If necessary, call a certified refrigeration service with the necessary knowledge of handling and maintaining equipment with refrigerants.

4 COMMISSIONING AND OPERATION



WARNING!

Risk of life-threatening or serious personal injury.

Electrical voltage can cause electric shock, burns and death. The product must not be energised during assembly.

- Electrical connection and electrical work may only be carried out by a qualified electrician.
- For initial start-up of the unit, see Operation and Maintenance of the unit on IV Produkt's Order portal.

00176



CAUTION!

Risk of damage to compressor.

Circulation of cold oil in the speed-controlled compressor may damage the compressor.

- The reversible heat pump must be powered up for at least 8 hours before it is first started.
- Make sure that no alarm is triggered about 30 seconds after the unit is energised. If an alarm is triggered, follow instructions for the alarm.

00188

Commissioning of the unit must be carried out by competent personnel according to documentation from IV Produkt. See "[Documentation for your unit](#)", page 2.

Documents for commissioning:

- Commissioning protocol (for units delivered with MX control equipment)
- Control diagram
- Connection instructions (separate manual for general connection and fuse protection)

Prior to commissioning, the customer shall ensure:

- that electricity is connected via a lockable safety switch.
- that the air heater/air cooler is connected.
- all ducts are connected, airways are cleaned and not obstructed.
- that dampers and air vents are connected and open.
- that there are no loose parts inside the unit.
- that, for cooling, drainage is routed to the floor drain

4.1 Switch off the unit for service.



The safety switch is not designed for starting and/or stopping the unit.

1. Switch off via the service switch in the control equipment.
2. Turn the safety switch to position 0.
3. Lock the safety switch.



Operation and maintenance

Envistar Top

4.2 Before commissioning

For reversible heat pumps with refrigerant R454B, make sure that external dampers communicate with the unit's control equipment so that the air flow through the unit cannot be blocked uncontrollably.

1. See "*1 SAFETY*", *page 7*.
2. Connect power via lockable safety switch.
3. Connect all ducts.
4. Wait at least eight hours before starting the unit.

4.3 Status information

4.3.1 Detection system

Climatix display

Information	Value/example	Explanation
Supply air		
Refrigerant leakage	Normal	Information about leak alarms
Alarm detector	Normal	Information about alarms on the detector
Concentration LFL	0.0%	Measured current refrigerant concentration
Chip temperature	22.2 °C	Internal detector temperature
Temperature heater	25.0 °C	Internal detector heater temperature
Firmware Version	1.0	Software version in the detector
Sensor ID	54291003	The detector's identification number
Extract air		
Refrigerant leakage	Normal	Information about leak alarms
Alarm detector	Normal	Information about alarms on the detector
Concentration LFL	0.0%	Measured current refrigerant concentration
Chip temperature	23.5 °C	Internal detector temperature
Temperature heater	25.0 °C	Internal detector heater temperature
Firmware Version	1.0	Software version in the detector
Sensor ID	54291211	The detector's identification number
Calibrate detector		Function to calibrate or test the detector
Calibration status supply air	OK	Calibration information
Calibration status extract air	OK	Calibration information

4.3.2 Cooling unit 04-12

Control equipment from IV Produkt Climatix display

Information	Value/example	Explanation
Cooling unit status	Unit ON	Normal status for cooling mode if the compressor is running depends on the cooling load.
	OFFbyALR	Switched off caused by alarm.
	OFFbyDIN	Switched off due to interlock. Climatix interlocks cooling operation.
	OFFbyKey	Switched off due to Carel's ON/OFF menu.
	High cond. temp.	The compressor's speed is limited due to high pressure.
Cooling	50%	Cooling load sent from Climatix to Carel.
Frequency inverter output signal	60%	
Compr. no		Compressor number, 1 x compressor (C1)
Compr. Sa.alarm		
Alarm management		

Compressor_C1	From/To	Compressor operating mode.
Suction gas temp_C1	17°C	Measured suction gas temp.
Evaporating temp_C1	10°C	Calculated evaporating temp based on low pressure.
Overheating_C1	7 K	Measured superheating.
Expansion valve_1	65%	Expansion valve position.
Refrigerant leakage	Normal	Information about leak alarms
Alarm detector	Normal	Information about alarms on the detector
Concentration LFL	0.0%	Measured current refrigerant concentration
Chip temperature	22.2 °C	Internal detector temperature
Temperature heater	25.0 °C	Internal detector heater temperature
Firmware Version	1.0	Software version in the detector
Sensor ID	54291003	The detector's identification number
Calibrate detector		Function to calibrate or test the detector
Calibration status supply air	OK	Calibration information
Calibration status extract air	OK	Calibration information



Operation and maintenance Envistar Top

Not control equipment from IV Produkt Carel display - Main menu > Status > I/O

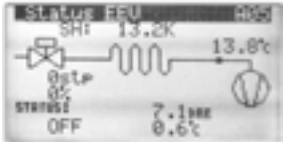
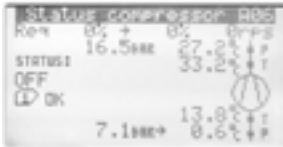
Information	Value/example	Explanation
Status A01		
U6 = Cool.demand:	50%	Cooling load from ventilation control
Remove start delay:	No / Yes	Opportunity to quick start the compressor if Yes is set.
J6 = Modbus Online:	No/Yes	Information about Modbus communication is received.
Modbus command:	Stop/start	Information about command received from Climatix.
Modbus demand:	50%	Information about cooling load received from Climatix.
Status A02		
High Press:	25.00 bar	High pressure
Disch.temp:	50.00°C	Hot gas temperature
Low press:	10.00 bar	Low pressure
Suct.temp:	17.00 °C	Suction gas temperature
Status A03		
U7 = start/stop	Stop	Input for interlock cooling operation
U10 = Alarm reset	No reset	Input to reset alarm
Status A04		
NO6 = General alarm	N/C	Output for sum alarm
Status A05		
		Overheating Suction gas temperature Valve opening Low pressure Evaporating temperature
Status A06		
		Cooling load, Output signal, Speed High pressure Condensing temperature Status Hot gas temperature Suction gas temperature Low pressure Evaporating temperature
Status A08		
Status	Off/Run/Alarm/ Heat	
Current	4.3 Arms	Compressor's power consumption
Voltage	124 Vrms	Power to compressor
Power	0.92 kW	Electrical output used by compressor
DC voltage	391 V	Internal voltage of the inverter
DC ripple	6 V	Variation of internal voltage of the inverter
Drive temp	40.0°C	The inverter's internal temperature
Status A09		
Working hour		Operating time
Compressor 1	50 h	

4.3.3 Cooling unit 17-22

Control equipment from IV Produkt with Siemens expansion valve control POL94M

Climatix display

Information	Value/example	Explanation
Regulator	50%	Cooling regulator output signal
Cooling output signal	50%	Cooling need
Cooling unit status	Text	Cooling unit status text
Service switch, cooling	Auto/Off	Setting to block/allow cooling mode
Alarm	-	Shows active alarms
Preferences	-	Preferences
DX cooling	From/To	Cooling need
Compressor C1	From/To	Compressor operating mode
Frequency inverter output C1	60%	Output signal from frequency inverter
Compr. frequency	Hz	Compressor frequency
Suction gas temp C1	17°C	Measured suction gas temp.
Evaporation temperature C1	10°C	Calculated evaporation temperature based on low pressure
MOP	°C	Max. evaporating temperature
Low pressure C1	3.5bar	Measured low pressure
Superheating actual value C1	7K	Measured overheating
Superheating setpoint C1	7K	Setpoint for superheating
Expansion valve actual value 1	35%	Expansion valve position
Expansion valve setpoint 1	35%	Expansion valve setpoint
High pressure C1	11.2bar	Measured high pressure
Condensation temp C1	45°C	Calculated condensing temperature based on high pressure.
Hot gas temp C1	75°C	Measured hot gas temperature
Liquid line temp C1	40°C	Measured liquid line temperature
Supercooling C1	5K	Calculated supercooling

Not control equipment from IV Produkt

Carel display - Main menu > Status > I/O

Information	Value/example	Explanation
Status A01		
B1 = Cool.demand:	50%	Cooling load from ventilation control
B2 = Heat demand	0%	Heating requirement
Remove start delay:	NO / YES	Opportunity to quick start the compressor if Yes is set.
Status A03		
ID1= Comp.1 alarm	O	Alarm IN for high-pressure switch and frequency inverter
B6 = Remote on/off	O	Interlock from ventilation control
Status A04		
EVD 1 - DI 1:	O	IN expansion control EVD
EVD 1 - DI 2:	O	IN expansion control EVD



Operation and maintenance Envistar Top

Information	Value/example	Explanation
Status A05		
NO1 = Compressor 1	O	OUT for compressor 1
NO2 = Global alarm	C	Alarm OUT for ventilation control
NO3 = 4way valve	C	Not used
Status A06		
Y2= Comp.inverter	0%	OUT signal 0-10V frequency inverter
J8= Modbus activity	NO	Shows whether Modbus is connected
Status A06b		
		Overheating Suction gas temperature Valve opening Low pressure Evaporating temperature
Status A10		
Working hour		Operating time
Compressor 1	50 h	
Status A11		
cCO address	1	Shows connected EVD on terminal J5

4.3.4 Reversible heat pump

Control equipment from IV Produkt Climatix display

Information	Value/example	Explanation
Status Cooling machine	UnitOn	Normal status for cooling mode if the compressor is running depends on the cooling load.
	OFFbyALR	Switched off caused by alarm.
	OFFbyDIN	Switched off due to interlock. Climatix interlocks cooling operation.
	OFFbyKey	Switched off due to Carel's ON/OFF menu.
	HighcondTmp	Compressor speed lowered due to the high pressure is high.
Status HP	FrostProtOpr	Compressor speed lowered to protect the evaporator from freezing. Results of extract air flow and extract air temperature.
	Alarm	The heat pump is in alarm mode.
	OffbyKey	Switched off due to Carel's ON/OFF menu.
	Temp ctrl.off	The unit is shut off.
	Cooling mode	The heat pump is in cooling mode.
	Low outdoor temp	The heat pump is blocked as the outdoor temperature is too low.
	Low air flow	The heat pump is blocked as the air flow is too low.
	Low return air temp	The heat pump is blocked as the return air temperature is too low.
	HP Tmp dead	The heat pump does not start due to a small temperature deviation.
	Switch off delay	The heat pump is prevented from switching off due to a short time since start.
	Switch on delay	The heat pump is prevented from starting due to a short time since stop.

Operation and maintenance Envistar Top



Information	Value/example	Explanation
	Heating mode	The heat pump is in heating mode.
	No need	No need to run the compressor in the heat pump.
Heating	0%	Heating requirement sent from Climatix to Carel.
Cooling	50%	Cooling load sent from Climatix to Carel.
Freq. inv. output	x.x%	Shows how much of the full capacity is used by the compressor.
Compr. no	Comp1	No. of compressors
Compr. Sa.alarm	Normal	Display of sum alarm.
Danfoss invert. Sa alarm		Sum alarm from the frequency inverter for the compressor.
Alarm	>	Alarm information in submenu.
Compressor C1	To/From	Compressor operating mode.
Suction gas temp C1	17 °C	Measured suction gas temp.
Evaporation temperature C1	10 °C	Calculated evaporating temp based on low pressure.
Low pressure C1	10 bar	Relative pressure from low pressure sensor.
Overheating C1	7 K	Measured superheating.
High pressure C1	25 bar	Relative pressure from high pressure sensor.
Expansion valve_1	80%	Expansion valve position
Condensation temp C	42.7°C	Calculated condensation temperature based on high pressure.
Hot gas temperature	75°C	Hot gas temperature
Liquid line T	40°C	Liquid line temperature
Sub-cooling	2.7°C	Sub-cooling
Compr. frequency	Hz	Compressor frequency
Overheating ref.	K	Setpoint for superheating. Adjusted automatically.



5 MAINTENANCE

5.1 Maintenance intervals

Checks and measures should be carried out at least every twelve months and/or as necessary. In the event of high moisture levels in extract air and in certain environments such as laundry rooms with chemicals, more frequent inspection and cleaning intervals are needed.

See recommended maintenance in the section for each unit part. A service list to facilitate maintenance is provided at the end of the manual.

5.2 Hygiene inspection VDI 6022 (optional extra)

For inspecting and maintaining hygiene according to the VDI 6022 standard, follow the instructions in this document and additional maintenance in separate documentation in the Order Portal.

5.3 Downtime

In case of prolonged standstill in air treatment systems (more than 48 hours), it should be ensured that no moist areas can be found downstream of the cooling coils or humidifier.

To avoid the accumulation of moisture in the unit – turn off the cooling coils and humidifier in good time and ventilate the air ducts until dry (gradual shut-down). Also set or program automatic dry blowing of the air cooler and downstream sections.

5.4 Switch off the unit before maintenance.



WARNING!

Risk of personal injury.

During operation, an overpressure can be created inside the unit.

- Allow the pressure to drop before you open the inspection doors.

00187



WARNING!

Risk of serious injury; shock or burns.

Applies to installed lighting EMMT-07: The lighting is supplied externally and does not switch off when power is cut through the unit's safety switch.

- Before maintenance or servicing, ensure that there is no power supply to the lamp.

00326



WARNING!

Risk of life-threatening or serious personal injury.

Electrical voltage can cause electric shock, burns and death. The unit must be turned off during maintenance.

- Shut down the unit at the service switch in the control equipment.
- Turn all safety switches to the 0 position. Note that the unit's parts may have separate safety switches.

00327



WARNING!

Risk of pinch injury, crush injury or cutting injury due to moving parts.

The device may start unexpectedly during remote control or demand-driven start-up.

- Control parameters may only be changed by personnel with extended privileges.
- The device must be turned off with all safety switches before covers can be opened.

00257



WARNING!

Risk of crushing, compression injury or cuts.

There is no contact guard on moving parts, such as rotating fan impellers, rotary heat exchangers and opening/closing dampers.

- The unit must not be powered until all ducts are connected.
- When the unit is in operation, inspection doors must be closed and locked.
- During service or other procedures, the unit must be switched off.
- Ensure power is off before placing hands in moving parts.
Fan inspection door: Wait at least 3 minutes after shutting down the unit before opening the door.
- Rotary heat exchanger inspection door: Wait at least 3 minutes after shutting down the unit before opening the door.
- Damper inspection door: Wait at least 3 minutes after shutdown before opening the hatch.
- Make sure that hands do not get caught in dampers that have a spring return (which can be closed even when not powered).

00185



WARNING!

Risk of burns.

The parts, pipes and components of the unit may be hot during and after operation of the unit.

- When the unit is in operation, inspection hatches must be closed and locked.
- During service or other interventions, the unit must be switched off.
- Inspection hatch for cooling unit/reversible heat pump: Wait at least 30 minutes after shutting down the unit before opening the compressor door.
- Inspection hatch for heating coil: Wait at least 5 minutes after shutting down the unit before opening the door.

00184



The safety switch is not designed for starting and/or stopping the unit.

The unit should always be switched off before starting any inspection or maintenance. A torch or headlamp can be used for inspection and maintenance.

1. Read "[1 SAFETY](#)", [page 7](#).
2. Read the warnings at the beginning of this chapter.
3. Switch off the unit via the service switch in the control equipment.
4. Lock all safety switches in the 0 position. Please note that different parts may have separate safety switches.
5. Before opening doors, wait until all fans have stopped.



Operation and maintenance

Envistar Top

5.5 Starting the unit after maintenance

1. Clear any alarms. See "[6.1 Reset the alarm.](#)", [page 47.](#)
2. Make sure that there are no loose items, such as tools, in the unit.

5.6 Maintain unit cabinets and surfaces



CAUTION!

Risk of damage to the product.

Corrosive substances and strong cleaning agents can damage the surface layer.

- Never use strong cleaning agents or corrosive substances when cleaning the unit.

00183



CAUTION!

Risk of damage to the product.

Swarf from drilling left behind after assembly can lead to corrosion and rust on the surface layer of the unit.

- Make sure that the surfaces of the unit are clean of swarf.

00195

1. Switch off the unit. See "[5.4 Switch off the unit before maintenance.](#)", [page 26.](#)
2. Vacuum the inside.
3. Wipe the interior surfaces with a damp cloth. Use warm water and mild (non-corrosive) detergent.
4. In case of heavy soiling, use an environmentally friendly degreaser. Follow the manufacturer's instructions.

5.7 Water trap maintenance



CAUTION!

Risk of environmental impact.

Depending on the business at which the unit is in operation, the extract air may contain environmentally harmful substances that can condense into drains from the unit.

- Ensure compliance with applicable national and international environmental regulations.

00380

Every 12 months and as needed

Make sure the water trap is working and not clogged.

Waste products and deposits in the water trap can cause flooding in the unit.

1. Open the water trap.
2. Flush the water trap with hot water, if necessary with added detergent. Make sure that no deposits remain. If ball is present - remove ball and clean.
3. Top up with water before operation.

5.8 Filter maintenance



WARNING!

Risk of inhalation of harmful particles.

When changing filters, particles, such as dust, may come loose from the used filter.

- Wear a protective mask when changing filters.
- Use caution when handling used filters.
- Thoroughly clean the filter cabinet after replacement as particulate matter may become loose and remain in the cabinet.

00325

At least every 12 months

Ensure (visually) that the unit parts are clean inside and out. See "[5.6 Maintain unit cabinets and surfaces](#)", page 28.

Replace the filter if it is dirty or clogged. Check the sealing gasket for damage and tightness along the entire contact surface of the filters. Replace if necessary. Filter replacement intervals vary depending on operating conditions and the amount of particles and odour-causing substances in the air. Manual checks only needs to be carried out if the unit is not equipped with FLC.

Replace the filter if the specified pressure drop is reached or the filter alarm is triggered.

In units with automatic filter control **FLC**, the filter alarm is triggered if a filter needs to be replaced.

Reset the filter control function on the hand-held terminal display before starting the unit. For more information, see separate control documentation for Climatix.

5.8.1 Replacing disposable bag filter or carbon filter

1. Switch off the unit. See "[5.4 Switch off the unit before maintenance](#)", page 26.
2. If there is a permanently mounted filter guard, detach the necessary measuring hoses to the hatch/post to be able to open the inspection hatch.
3. Pull the red handles until the filter comes loose from the rails and stops.

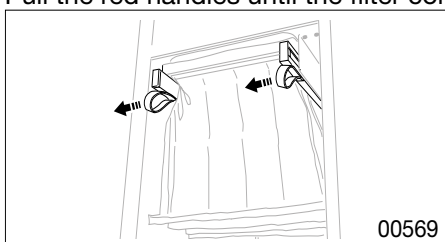

4. Grasp the frame of the filter and gently pull the filter outwards. Lift it out carefully.
5. Place the used filter in a bag/rubbish bag and seal. Some filter kits include bags for filter replacement.
6. Check and ensure that the gaskets in the filter frame are intact.
7. Remove any dirt that has accumulated ahead of the filter.
8. Clean the inside of the unit cabinet. See "[5.6 Maintain unit cabinets and surfaces](#)", page 28.
9. Install a new filter. Make sure it is pushed in as far as it will go into the filter cabinet.
10. Press the filter locks (at the red handles) until you hear a clicking sound.
11. Close the inspection hatch.
12. Dispose of the used filter according to applicable environmental regulations. See "[8 DECOMMISSIONING AND RECYCLING](#)", page 54.



Operation and maintenance Envistar Top

5.8.2 Cleaning the aluminium filter

1. Switch off the unit. See "[5.4 Switch off the unit before maintenance.](#)", page 26.
2. When the fans have stopped, open the inspection hatch.
3. Pull out filter.
4. Brush the filter with a soft brush.
5. Gently vacuum the surface with a soft vacuum nozzle.
6. Wipe the filter with a wet cloth or rinse it under warm water. Use mild (non-corrosive) detergent.
7. In case of heavy soiling, use an environmentally friendly degreaser. Follow the instructions on the packaging.
8. Clean the inside of the unit cabinet. See "[5.6 Maintain unit cabinets and surfaces](#)", page 28.
9. Refit the filter.

5.8.3 Check pressure drop across filter

Only applies if the AHU (air handling unit) is not equipped with filter monitoring.

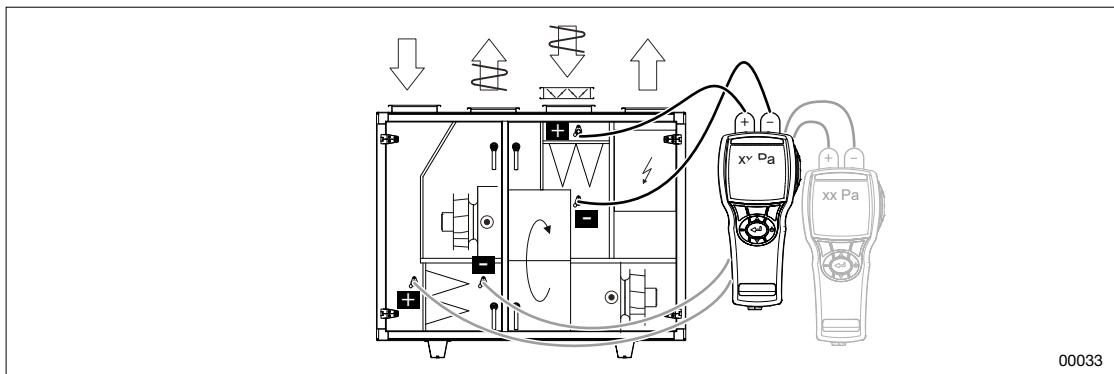

00033

Figure: Check pressure drop across filter

1. Measuring socket on extract air side
 2. Extract air filter
 3. Pressure gauge for extract air filter
 4. Pressure gauge for supply air side
 5. Supply air filter
 6. Measuring socket on supply air side
1. Connect the pressure gauge to the measuring outlets on each side of the filters.
 2. Measure the filter pressure drop.
 3. Compare the value with the initial pressure drop measured when the unit was put into operation (on the filter part label).

FILTERDATA

Nominellt luftflöde m³/s
 Nominal air flow..... m³/h

Antal filter Mått
 Number of filters.....Dimensions.....

Filterklass/Filter Class.....

Begynnelsestryckfall
 Initial Pressure Drop.....Pa

Sluttryckfall
 Final Pressure Drop.....Pa

Art. Nr: 19121-1101_02SV

4. Replace filter if pressure drop reaches final pressure drop as listed in Technical Data.
5. Repeat the procedure for the supply air filter.

5.9 Maintenance of rotary heat exchanger



CAUTION!

Risk of damage to the product.

Touch and contact may damage the surface layer of the rotary heat exchanger.

- Make sure that the surface does not come in contact with tools or any part of the body.
- When working with the rotary heat exchanger, wear protective gloves.

00270

Every 12 months and as needed

Ensure (visually) that the unit parts are clean inside and out. See "[5.6 Maintain unit cabinets and surfaces](#)", [page 28](#).

Visually confirm that the thermal wheel surface is clean and free of coatings (dust, etc.) and that the air ducts in the thermal wheel surface are not clogged.

Visually confirm that the brush strip is clean and intact and seals against the side plates. Replace brush strip if thermal wheel surface is visible through the brush, if brush strip is broken, or if soiled.

Make sure, by hand, that the thermal wheel rotates easily. If the wheel feels sluggish, check the vertical position of the thermal wheel for abnormal tilting. Refer to Assembly Instructions to adjust the thermal wheel. Make sure brush strips are flush and not damaged. Replace if necessary. See spare parts list for new brush strip.

Make sure the drive belt is intact and clean and that it is taut with no slipping. The correct speed is at least 8 rpm when recovery is required. Adjust drive belt if necessary. See spare parts list for new drive belt.

Ensure that pressure balance between measuring sockets P2 and P3 corresponds to the set pressure balance setpoint (-10 Pa) in the control unit. Adjust trim damper if necessary. See "[5.15 Damper maintenance](#)", [page 45](#).

Check the differential pressure across the thermal wheel and adjust the purging sector if the value is incorrect. See "[5.9.6 Check differential pressure across rotary heat exchangers](#)", [page 36](#).

Ensure that the pressure balance and leakage direction are correct. Adjust the purging sector if the value is incorrect.

5.9.1 Cleaning the rotary heat exchanger



- The thermal wheel's purging function ensures that the ducts do not become clogged. If the air contains sticky dust, manual cleaning may be necessary.
- The rotary heat exchanger is automatically run to prevent odours.
- The bearings and drive motor are permanently lubricated and do not require additional lubrication.
- When applying liquid to the surface of the thermal wheel during cleaning, it is recommended that the unit is running to avoid moisture or excess liquid remaining in the unit. The purging sector should be fully open and the rotational speed should be 8 rpm to ensure adequate detergent intake. Post-rinsing is not normally required.



Operation and maintenance

Envistar Top

1. Switch off the unit. See "[5.4 Switch off the unit before maintenance.](#)", [page 26](#).
2. When the fans have stopped, open the inspection hatch.
3. Vacuum gently with a soft vacuum cleaner nozzle.
4. Wipe with a wet cloth or rinse under warm water. Use mild (non-corrosive) detergent.
5. Use low-pressure compressed air to blow the thermal wheel ducts clean. To avoid damage, the compressed air nozzle must not be held closer than 5-10 mm from the thermal wheel surface. Compressed air pressure on the heat exchanger's thermal wheel surface must not exceed 6 bar.
6. For heavy or oily soiling, spray the thermal wheel surface with a mixture of water and detergent that does not corrode aluminium or use a cleaning agent specifically designed for heat exchangers, such as Re-Coilex.
7. To remove residual odours, spray the surface with a mild alkaline detergent. If possible, apply while the AHU (air handling unit) is running, so that the detergent is drawn through the thermal wheel.
8. Clean the inside of the unit cabinet. See "[5.6 Maintain unit cabinets and surfaces](#)", [page 28](#).

5.9.2 Replacing the brush strip

Remove and fit a new brush strip to the upper intermediate level

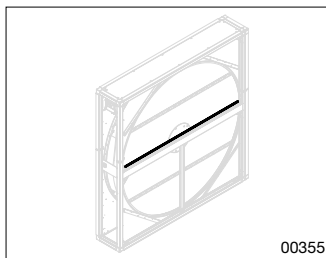

1. Switch off the unit. See "[5.4 Switch off the unit before maintenance.](#)", [page 26](#).
2. Unscrew the old strip.
3. Cut a new seal brush strip in the same length as the old one.
4. Screw the new one in the same place as the old one.
5. Make sure it seals against the side plate.

Remove and fit a new brush strip around thermal wheel

1. Switch off the unit. See "[5.4 Switch off the unit before maintenance.](#)", [page 26](#).
2. Lift the drive belt off the pulley. Make sure that the drive belt does not settle too far out towards the edges as it may get stuck when the thermal wheel is rotated.
3. Rotate the wheel upwards until the brush strip joint is visible.
4. Continue rotating the wheel while unscrewing the brush strip screws except the two that are on both sides of the joint.

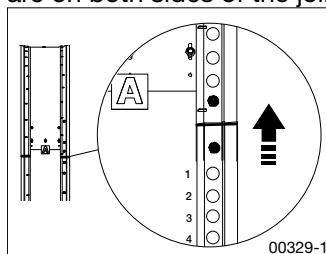

5. Hold the brush strip and unscrew the last two screws, above and below the joint. The brush strip is now loose.
6. Grip one end and pull out the brush strip completely.
7. Cut a new brush strip in the same length as the existing one.
8. Place one end of the new brush strip where the old joint was.

9. Screw in the first screw closest to the joint. Make sure the brush is flush against the surface of the thermal wheel.

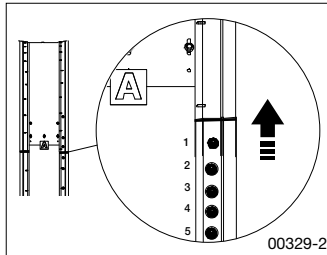

10. Rotate the wheel upwards and screw the entire brush strip into the joint using self-tapping screws. Use the holes located on the brush strip. It is sufficient to use every other hole. Preferably make new holes in the thermal wheel. Make sure that the brush is flush against the surface of the thermal wheel at each screw and that it is flush at the joints of the thermal wheel.
11. When all screws are in place, insert a thin string into the joint where the ends of the brush strip meet.

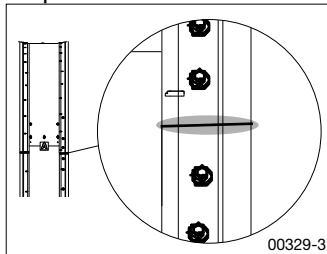

12. Open the inspection door next to the thermal wheel on the side where the brush strip has been replaced. Place a putty string between the thermal wheel and brush strip and into the joint so that the brush strip seals.
13. Lift the drive belt onto the pulley. It does not need to be exactly centred on the surface of the thermal wheel because it adjusts automatically as the thermal wheel moves.

5.9.3 Replacing or shortening the drive belt



- The thermal wheel is operated with a round belt or v-belt or depending on the size of the thermal wheel. For the correct belt and belt length, refer to the Spare Parts list.
- Never use grease or other lubricants to push the pin into place in the round belt.

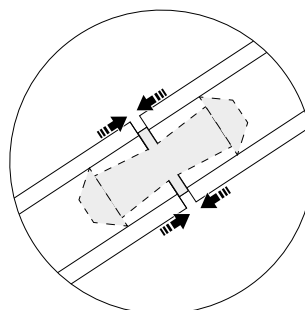

00634

Figure: Cross-section of round belt and v-belt

1. Switch off the unit. See "[5.4 Switch off the unit before maintenance.](#)", [page 26](#).
2. Remove the old belt.
3. Measure a new belt, or tighten the existing belt by pulling it together to the correct length. For lengths, refer to the Spare Parts list.



Operation and maintenance Envistar Top

4. Cut off the excess.
5. Fit the new belt around the thermal wheel in the same way as the old one. Make sure that the v-belt is correctly positioned in the pulley groove. It is advisable to tape the end so that the belt attaches when the wheel is rotated. It does not need to be exactly centred on the surface of the thermal wheel because it adjusts automatically as the thermal wheel moves.
6. Tighten and join the belt by pushing the round belt over the cones on the pin. Make sure the belt splice is centred over the centre of the pin and as taut as possible. Use tongue-and-groove pliers or a similar tool.
7. Remove the tape when the belt is spliced.

Before starting

1. Clear any alarms. See "[6.1 Reset the alarm.](#)", page 47.

5.9.4 Check pressure balance/leakage direction - Home Concept (with automatic pressure balance control)

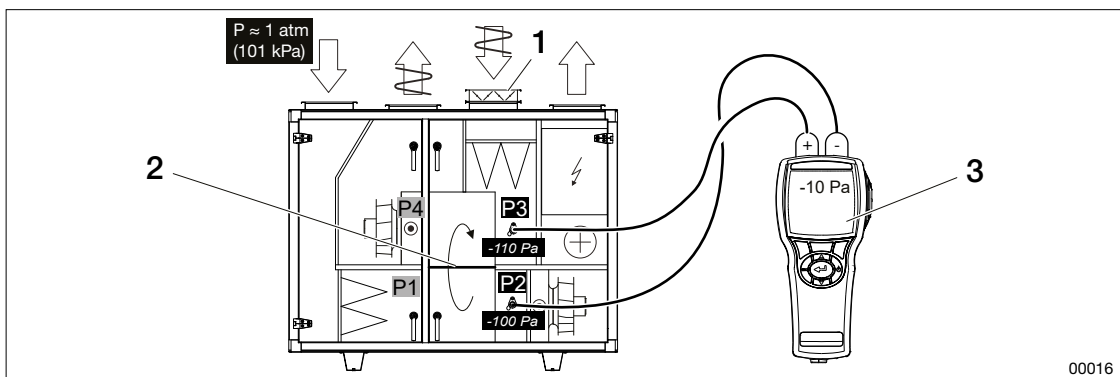

1. Trim damper with damper motor
2. Rotary heat exchanger with purging sector
3. Pressure gauge

Trim damper ETSP-UM/TR automatically regulates the pressure balance against the set value in the process unit. In AHUs (air handling units) without control equipment, the function is not factory-connected and must be connected by the customer.

1. Connect the pressure gauge negative side to P2 and the positive side to P3.
2. Measure the pressure difference.
3. Ensure that the measured pressure balance between measurement outlets P2 and P3 corresponds to the set pressure balance setpoint in the process unit (-10 Pa).
4. If the pressure balance is not correct, ensure that the trim damper is working (closes and opens mechanically).

Example:

- P2: Downstream supply air fan (SF) generates negative pressure in relation to the atmospheric pressure (atm), e.g. -100 Pa
- P3: Measurement outlets for P3: Downstream extract air fan (EF) and trim damper generate greater negative pressure than at P2, e.g. -110 Pa.

5.9.5 Check the pressure balance in the AHU (air handling unit) with manual trim damper

The pressure balance is ensured when the negative pressure P3 is greater than the negative pressure P2 (min. diff 25 Pa).

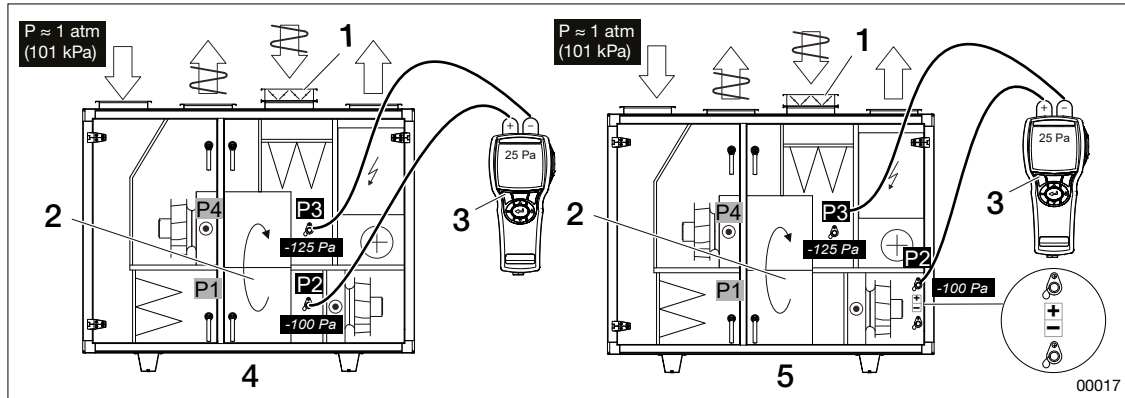

Figure: Measurement outlets for pressure balance – AHU (air handling unit) with control equipment

- | | |
|--|------------------------------------|
| 1. Trim damper (manual) | 4. With control from IV Produkt |
| 2. Rotary heat exchanger with purging sector | 5. Without control from IV Produkt |
| 3. Pressure gauge | |

1. Connect the pressure gauge positive side to P2 and the negative side to P3.
2. Measure the pressure difference.
3. If the pressure balance does not correspond to ≥ 25 Pa, at rated air flow and clean filters, adjust the trim damper.

Example:

- P2: Measurement outlets for P2: Downstream supply air fan (SF) generates negative pressure in relation to the atmospheric pressure (atm), e.g. -100 Pa
- P3: Measurement outlets for P3: Downstream extract air fan (EF) and any trim damper generate greater negative pressure than at P2, e.g. -125 Pa.



Operation and maintenance Envistar Top

5.9.6 Check differential pressure across rotary heat exchangers

During manufacturing and assembly, the thermal wheel is adjusted to stand straight in the frame, but at high air pressure across the thermal wheel, it may need to be positioned against the direction of air to stand straight during operation.

Control during operation:

1. Open the inspection door and visually check that the brush strip extends equally at the top and bottom of the thermal wheel. Use caution when the inspection door is open. The thermal wheel rotates and there is a moderate pinching hazard at the belt. Do not touch the thermal wheel.
2. If necessary, the thermal wheel can be arranged in a y-direction towards the air direction. For instructions, refer to the unit's Assembly Instructions. When adjusting, the thermal wheel must be turned off.

Before checking differential pressure across rotary heat exchangers, check pressure balance according to "[5.9.4 Check pressure balance/leakage direction - Home Concept \(with automatic pressure balance control\)](#)", page 34 and "[5.9.5 Check the pressure balance in the AHU \(air handling unit\) with manual trim damper](#)", page 35.

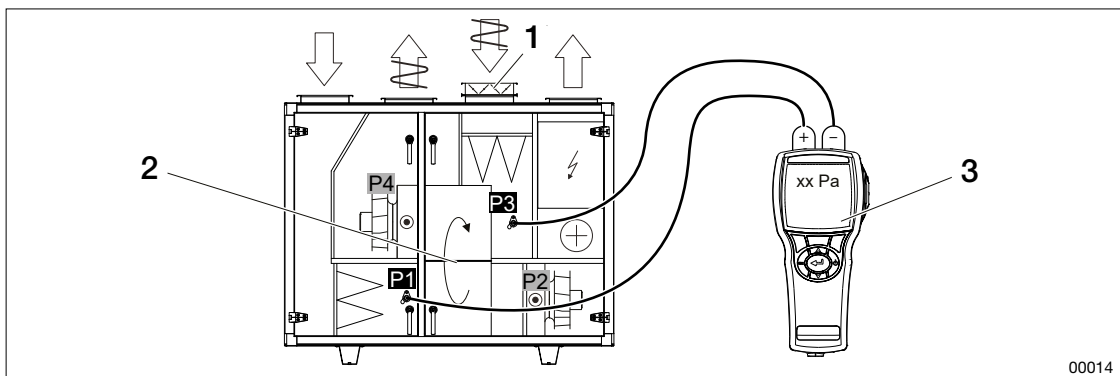

1. Trim damper
2. Rotary heat exchanger with purging sector

3. Pressure gauge

1. Connect the positive side of the pressure gauge to P1 and the negative side to P3.
2. Measure the pressure difference between outdoor air (P1) and extract air (P3).
3. Adjust the purging sector if the measured value does not match the recommended values in "[5.9.8 Purging sector - setting values](#)", page 37.

5.9.7 Adjusting the purging sector



- To adjust the thermal wheel, follow the instructions and observe the warnings in the unit's Assembly Instructions. The manual is available at IV Produkt's order portal.

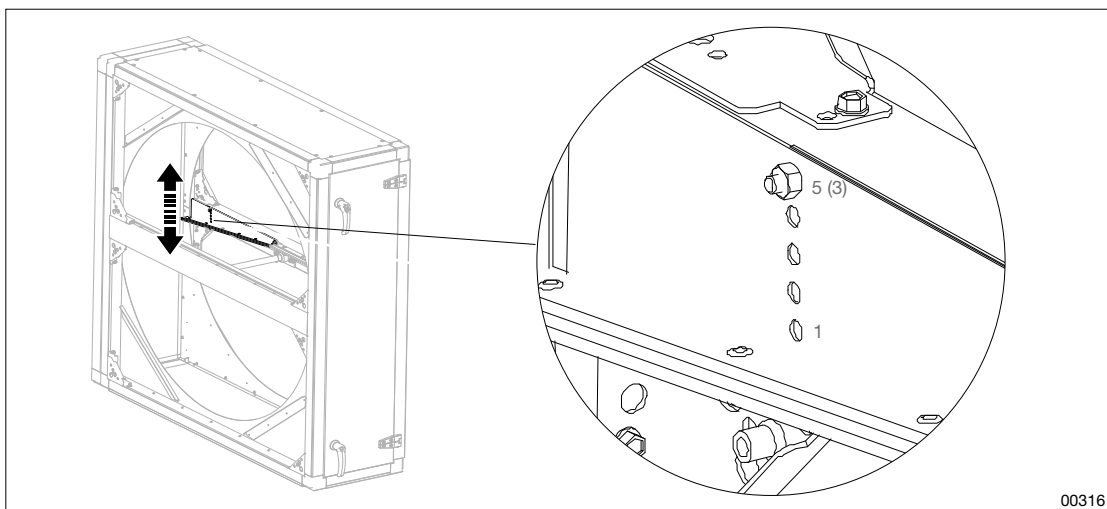

Figure: Purging sector from the back of the thermal wheel. Adjustment holes for setting (3 holes on smaller thermal wheels and 5 holes on larger ones).

- Switch off the unit. See "[5.4 Switch off the unit before maintenance.](#)", page 26.
- Loosen the screw and move the purging sector plate up or down.
- Screw the screw into the pre-drilled screw holes according to the values in "[5.9.8 Purging sector - setting values](#)", page 37.

5.9.8 Purging sector - setting values

Table for the purging sector - smaller thermal wheel size

Adjustment hole in the purging sector	Thermal wheel variant: R20, R30, R40	Thermal wheel variant: R50, R60
	Pressure diff. P1 – P3 (Pa)	Pressure diff. P1 – P3 (Pa)
3 (open)	< 300	< 400
2	> 300	> 400
1 (closed)	-	-

Table for the purging sector - larger thermal wheel size

Adjustment hole in the purging sector	Thermal wheel variant: R20, R30, R40, NO, NE, HY, HE, EX	Thermal wheel variant: R50, R60, NP, NX, HP
	Pressure diff. P1 – P3 (Pa)	Pressure diff. P1 – P3 (Pa)
5 (open)	< 200	< 300
4	200 – 400	300–500
3	400–600	500–700
2	> 600	> 700
1 (closed)	-	-



5.10 Maintenance of counter-flow heat exchangers

Every 12 months and as needed
Ensure (visually) that the unit parts are clean inside and out. See " 5.6 Maintain unit cabinets and surfaces ", page 28 .
Visually confirm that sealing strips are in place, sealed and undamaged.
Visually confirm that the coil fins are clean and undamaged.
Visually confirm that the bypass damper is tightly shut when defrosting is not taking place.
Visually confirm that the dampers are in the correct position (closed or open) depending on whether there is a frost or freeze risk.
Visually confirm that drip tray, bottom plate, and drain are clean. Clean if necessary.
Ensure that the water trap (without non-return valve) is water filled and not clogged. See " 5.7 Water trap maintenance ", page 28 .
Make sure that the defrost function (ODS) works.
Ensure that the freeze protection (BYP) works.

5.10.1 Cleaning heat exchangers

1. Switch off the unit. See "[5.4 Switch off the unit before maintenance](#)", [page 26](#).
2. When the fans have stopped, open the inspection hatch.
3. Gently vacuum the coil fins with a soft vacuum nozzle or use low pressure compressed air.
4. Before flushing with warm water, check that the drain and water trap are working.
5. Flush with warm water. Use mild, non-corrosive cleaning agents that do not corrode aluminium. High pressure flushing must not be directed at the fins. Perform flushing carefully to ensure that the fins do not become deformed or break.
6. Clean the inside of the unit cabinet.
7. Check and clean the water trap.

At operating temperatures below 0°C, ensure that the heat exchanger is dry before commissioning.

5.10.2 Checks

Checking damper for defrosting function (ODS)

The defrost function starts automatically if defrosting is necessary. The program is pre-set upon delivery and may not be adjusted or modified without support from IV Produkt.

	Damper over heat exchanger	Bypass damper
Full heat recovery	Fully open	Closed
Shut down unit	Closed	Closed
Defrosting active	In different modes	Partially open

Check the damper for freeze protection (BYP)

Freeze protection starts automatically when the temperature on the exhaust air side falls below the temperature at a reference point in a given location. For units with MX control equipment, the program is pre-set upon delivery and must not be adjusted or changed without support from IV Produkt. For units without control equipment (MK, US, UC), it must be programmed and integrated into external control equipment by the customer.

	Damper over heat exchanger	Bypass damper
Full heat recovery	Fully open	Closed
Shut down unit	Fully open	Closed
Frost hazard exists	Partially open	Partially open



5.11 Fan maintenance

Every 12 months and as needed
Ensure (visually) that the unit parts are clean inside and out. See " 5.6 Maintain unit cabinets and surfaces ", page 28 .
Ensure (visually) that the fan parts are clean and dust-free.
Ensure: - that the fan does not make any unusual noises (for example, scraping, thumping or rattling noises). - that the fan does not vibrate or is unbalanced. Well-functioning bearings emit a faint humming sound. If the fan appears to be damaged, contact a service technician.
Ensure (visually) that the impeller overlaps the inlet cones.
Ensure (visually) that the fan rotates in the direction indicated by the markings on the fan. If the fan has the wrong rotation direction, contact a service technician.
Ensure (visually) that the fixing screws, suspension devices, stand, vibration dampers and gaskets (around the connection hole) are secure and undamaged. Tighten or replace if necessary.
Check the ring line for flow measurement.
Check and ensure that the overheat protection is working properly.
Check and ensure that airflows match settings.

5.11.1 Clean the fan and motor

1. Switch off the unit. See "[5.4 Switch off the unit before maintenance](#)", [page 26](#).
2. When the fans have stopped, open the inspection hatch.
3. Remove fans. See **the Assembly Instructions** for the unit. Note how the hoses are positioned before removing.
4. Vacuum the fan and motor carefully with a soft vacuum cleaner nozzle.
5. Wipe the fan wheel and surfaces with a damp cloth. Use warm water and mild (non-corrosive) detergent.
6. For heavier soiling, use an environmentally friendly degreaser.
7. Clean the inside of the unit cabinet. See "[5.6 Maintain unit cabinets and surfaces](#)", [page 28](#).
8. Put the fan back in place. See **the Assembly Instructions** for the unit.
9. Ensure that all hoses and connectors are returned to their original locations.

5.11.2 Checks

Check/adjust overheating protection

Risk of internal overheating if thick layers of dirt prevent cooling of the motor stator frame.

Reset overheat protection (applies to ELFF-EC01, -EC02, -ECA2)

1. Disconnect power to the fan motor.
2. Wait at least 20 seconds after the impeller stops rotating.
3. Restore power to the fan motor.

Check air flow.

Too high a pressure drop in the duct system can lead to too low an air flow, which can cause a poor room climate, for example, humid air can be pushed out into the building.

AHU (air handling unit) with control equipment from IV Produkt

Read the displayed flow on the hand-held terminal display.

AHU (air handling unit) without control equipment from IV Produkt

4. Measure Δp in the measuring outlets for flow measurement +/-
5. Read the AHU (air handling unit)'s flow sign to determine which flow corresponds to the measured Δp .

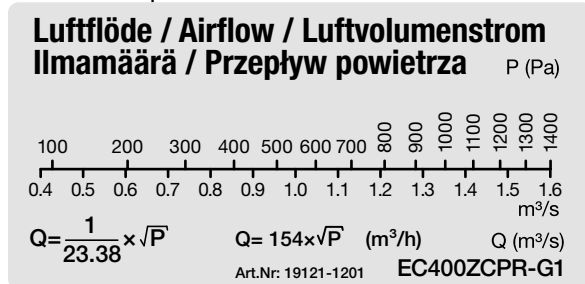

Check the ring line for flow measurement

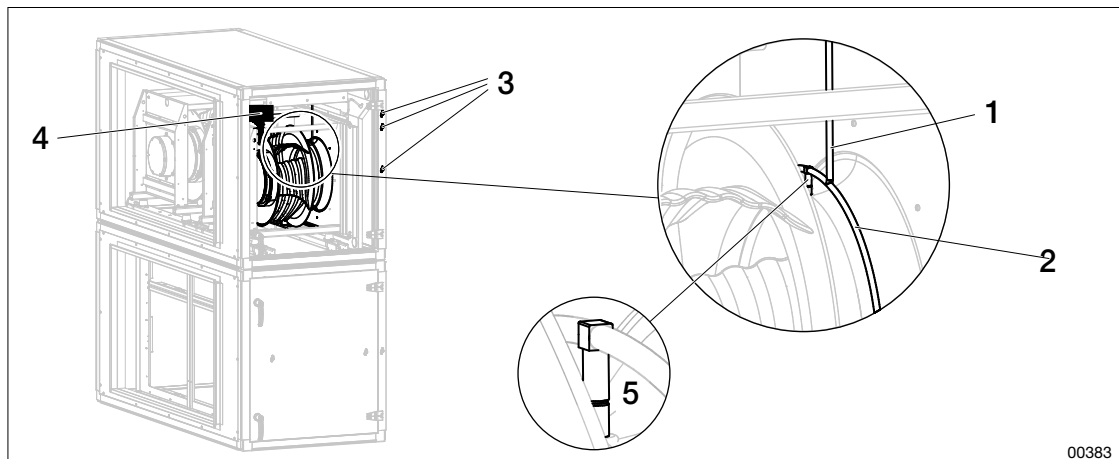

Figure: Check ring line

- | | |
|-----------------------|---------------------|
| 1. Measuring hose | 4. Pressure sensor |
| 2. Ring line | 5. Measuring nipple |
| 3. Measurement outlet | |

Check the hose routing and ensure:

- that the ring line is attached to the respective measuring nipple on the fan cone
- that the ring line is undamaged and not leaking.
- that the measuring hose is attached to the ring line.
- that the entire hose between the ring line and the pressure sensor/measurement outlet is undamaged and not pinched or leaking.



5.12 Maintenance of air heater/air cooler water

	WARNING! Risk of burns. <i>The parts, pipes and components of the unit may be hot during and after operation of the unit.</i>
	<ul style="list-style-type: none">• When the unit is in operation, inspection hatches must be closed and locked.• During service or other interventions, the unit must be switched off.• Inspection hatch for cooling unit/reversible heat pump: Wait at least 30 minutes after shutting down the unit before opening the compressor door.• Inspection hatch for heating coil: Wait at least 5 minutes after shutting down the unit before opening the door.

00184

Every 12 months and as needed
Ensure that the fins are clean and undamaged. If they are damaged, contact a service technician.
Make sure that the air heater is not leaking. In case of leakage, contact a service technician.
Ensure (visually) that the drip tray and bottom plate are clean. Clean if necessary.
Ensure that the water trap (without non-return valve) is filled with water. See " 5.7 Water trap maintenance ", page 28.
Ensure that the system pressure is the same as at installation. If necessary, top up the system with fluid.
Ensure that air heater/air cooler water is aerated.
Ensure that the water flow is correct, according to Technical Data.
Air heaters Thermoguard have additional maintenance. See " 5.12.4 Additional maintenance Thermoguard air heater ", page 43.

5.12.1 Clean air heater/air cooler water

1. Switch off the unit. See "[5.4 Switch off the unit before maintenance.](#)", page 26.
2. When the fans have stopped, open the inspection hatch.
3. From the inlet side: Vacuum gently with a soft vacuum cleaner nozzle.
4. From the outlet side: Blow clean carefully with compressed air.
5. For heavier soiling, spray with warm water with added detergent, which does not corrode aluminium.
6. Clean the inside of the unit cabinet. See "[5.6 Maintain unit cabinets and surfaces](#)", page 28.

5.12.2 Check that air heater/air cooler water regulates heating/cooling

Cooling is blocked when the outdoor temperature drops below the set value for cooling start.

1. Temporarily raise (for heat) or reduce (for cooling) the temperature setting (setpoint) to check that the air heater/air cooler water is providing the intended temperature.

5.12.3 Aerate air heater/air cooler water

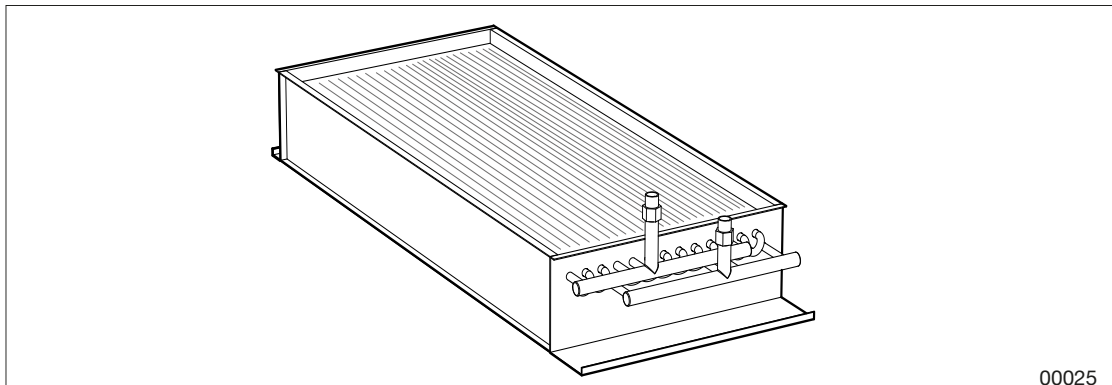

Figure: Air heater water (ETAB-VV)

1. Switch off the unit. See "5.4 Switch off the unit before maintenance.", page 26.
2. Prime the pipes by opening the bleed screw/nipple in the pipe connection (top of the coil) and/or air vessel.
3. Check pressure in the expansion tank and top up water/glycol if necessary

5.12.4 Additional maintenance Thermoguard air heater



CAUTION!

Risk of damage to Thermoguard air heater.

Start-up of a frozen air heater can severely damage or destroy the product.

- Ensure that the air heater is fully thawed before putting into operation again.

00354

Every 12 months and as needed

Ensure that the pressure relief valve is not leaking. Flush or replace valve regularly, preferably more frequently than every 12 months.

Make sure the coil is not frozen.

Checking/cleaning the pressure relief valve

The air heater must be fitted with a safety valve to protect against freezing. Shut-off valves on the supply or return lines must not be closed if freezing temperatures are likely. The safety valve is installed by the customer.

A leaking valve may be due to impurities from the pipe system that have accumulated on the valve seat. If the leakage is not stopped after flushing, the pressure relief valve must be replaced with a valve of the same type and with the same opening pressure.

1. Flush the valve seat by gently turning the valve knob.
2. If leakage persists, replace the valve with one of the same type, with the same opening pressure.

Defrost frozen Thermoguard air heater

If the heat recovery unit is located:

- ahead of the air heater, run recovery until the air heater defrosts.
- after the air heater, use an external heat source to defrost the air heater.

Before start-up, ensure that the air heater, elbows, and pipes are completely defrosted. When the air heater is fully defrosted, the liquid pressure drop (at full liquid flow over the air heater) must be consistent with the measured liquid pressure drop according to the adjustment protocol.



Operation and maintenance Envistar Top

5.13 Maintenance of air heater electric

WARNING!

Risk of burns.

The parts, pipes and components of the unit may be hot during and after operation of the unit.



- When the unit is in operation, inspection hatches must be closed and locked.
- During service or other interventions, the unit must be switched off.
- Inspection hatch for cooling unit/reversible heat pump: Wait at least 30 minutes after shutting down the unit before opening the compressor door.
- Inspection hatch for heating coil: Wait at least 5 minutes after shutting down the unit before opening the door.

00184

Every 12 months and as needed

Visually confirm that the air heater is clean and undamaged.

Make sure that the overheat protection works. If the overheat protection has tripped, the cause must be determined and corrected before the system is re-started.

Visually confirm that the air heater is attached to the suspension and not deformed. If damaged, contact a service technician.

5.13.1 Cleaning the air heater electric

1. Switch off the unit. See "[5.4 Switch off the unit before maintenance.](#)", [page 26](#).
2. When the fans have stopped, open the inspection hatch.
3. Vacuum gently with a soft vacuum cleaner nozzle.
4. Wipe with a dry cloth.
5. Clean the inside of the AHU (air handling unit) cabinet. e "[5.6 Maintain unit cabinets and surfaces.](#)", [page 28](#).

5.13.2 Checking the overheat protection



The air speed should not be lower than 1.5 m/s. At lower air speeds, the risk of overheating increases and the overheat protection trips.

The overheat protection is located on the air heater side, on the cover panel. It triggers at around 120°C. The air heater is equipped with double temperature delimiters. The automatic reset should be set to 70 °C.

1. Simulate a reduced power requirement by lowering the temperature setting (setpoint) so that all electrical steps (contractors) are OFF.
2. Greatly increase the setpoint and check that the electrical steps are ON.
3. Reset the setpoint.
4. Stop the unit without cutting power via the safety switch. All electrical steps (contractors) will turn OFF. Please note that the unit stop may be delayed approximately 2-5 minutes to cool down the air heater.

Manually resetting the overheat protection

If the unit triggers an alarm for electric heater failure, press the electric heater reset button and listen for clicking sounds.

5.14 Maintenance of refrigerant circuit

5.14.1 Checks/record keeping, according to the European F-gas Regulation



Leakage checks must be carried out by a certified refrigeration certified technician. See "[1.11 Handling of refrigerant](#)", [page 10](#) and in accordance with applicable national legislation.

Different countries may have different regulations regarding leakage control and registration.

5.14.2 Registry administration of events/inspections

The operator must record events, such as the volume and type of refrigerant topped up, refrigerant taken into possession, results of inspections and work done, persons and companies who carried out service and maintenance.

5.14.3 Use and inspection of pressurised equipment

Inspection must be carried out in accordance with the applicable national legislation.

5.14.4 Country-specific requirements and laws

Unless otherwise specified in this manual, comply with national legal requirements regarding leakage control and registry administration according the country in question.

5.14.5 Refrigerant detector system

For a description of the function of the Detector System, see "[3.7 Refrigerant detector system](#)", [page 18](#).

5.15 Damper maintenance

Every 12 months and as needed

Visually confirm that the damper is clean and undamaged.

Ensure (visually) that the damper opens and closes properly. In the event of a fault, contact a service technician.

Ensure (visually) that the damper seals when closed. Adjust the actuator (not for trim dampers). Make sure that no screws are installed through the drive mechanism/damper blades.

Make sure that the trim damper for the thermal wheel purging function works.

Ensure that gaskets are undamaged and leak-proof. Replace damaged gaskets.



Defective function of shut-off dampers can lead to an increased fire risk.



Operation and maintenance Envistar Top

5.15.1 Clean dampers

1. Switch off the unit. See "[5.4 Switch off the unit before maintenance.](#)", [page 26](#).
2. When the fans have stopped, open the inspection hatch.
3. Vacuum gently with a soft vacuum cleaner nozzle.
4. Wipe with a damp cloth. Use warm water and mild (non-corrosive) detergent.
5. For heavier soiling, use an environmentally friendly degreaser. Follow the instructions on the packaging.

5.15.2 Control

Check/adjust dampers

Adjust the damper motor

Ensure that the damper closes and opens fully. If not, adjust the damper motor on the damper shaft.

Checking/adjusting trim damper for thermal wheel purging function

If the trim damper for the thermal wheel purging function is not working or is incorrectly set, it may result in odours from the extract air being transferred to the supply air via the thermal wheel. Make sure that the damper closes and opens correctly and that it is correctly set.

Check packing

1. Feel the gasket with your hands and make sure it has no nicks or damage.
2. Check and ensure that the gasket is tight and has no gaps.

5.16 Sound attenuator maintenance

Every 12 months and as needed

Ensure (visually) that the surfaces of the baffle elements are clean and undamaged. "[5.6 Maintain unit cabinets and surfaces](#)", [page 28](#).

6 ALARM



The operating parameters of the reversible heat pump or cooling unit may not be changed so that they are outside the operating range of the AHU (air handling unit). If errors occur, an alarm is triggered and:

- the compressor is stopped.
- a red light flashes on the Climatix display and on the Carel unit.

Call authorised refrigeration service if the same alarm repeats after action has been taken.



- In the event of an alarm, a **red light** flashes on the hand-held terminal.
- After taking action, reset the alarm by following the instructions in the quick manual; label affixed to AHU (air handling unit).

6.1 Reset the alarm.

1. Check what the alarm means.
2. Take action as described.
3. Hold down the Carel display button (*Alarm reset*) for about three seconds.

6.1.1 Alarm reset - High-pressure switch tripped

Press the red button on the pressure switch.



6.1.2 Alarm reset - Alarm from the inverter or compressor

De-energise the AHU (air handling unit) for at least 1 minute.



Operation and maintenance

Envistar Top

6.2 Alarm Control system AHU (air handling unit)



Leak checks and replacement of parts in the refrigerant circuit must be carried out by a certified refrigeration technician. See "[1.11 Handling of refrigerant](#)", page 10.

Alarm code	Possible cause	Measure
Compr. Sa.alarm	Sum alarm.	See alarms in Carel table
C1 H. pressure switch	High pressure switch triggered. Alarm on frequency converter.	Reset the high pressure switch by pressing the red button. Reset the frequency converter by turning off the 3-phase supply (wait 60 seconds) and turning on the 3-phase supply.
C1 EEV engine fault	Fault in the electrical connection to the expansion valve.	Ensure that there is a correct electrical connection to the expansion valve.
C1 low pressure sensor	Open circuit or short circuit to low pressure sensor.	Check that the EVD and sensors are working and that there are no breaks in the cables.
C1 suction gas sensor	Open circuit or short circuit to suction gas sensor.	Check that the EVD and sensors are working and that there are no breaks in the cables.
C1 high pressure sensor	Open circuit or short circuit to high pressure sensor.	Check that the EVD and sensors are working and that there are no breaks in the cables.
C1 low overheating	Compressor stop caused by low overheating.	Reset the alarm so that the compressor can restart. During compressor operation, ensure that the expansion valve regulates the overheating to its setpoint.
C1 LOP	Compressor stop caused by low evaporation temperature.	Reset the alarm. In the event of recurring errors, contact authorised service personnel.
C1 MOP	Compressor stop caused by high evaporation temperature.	Reset the alarm so that the compressor can restart. During compressor operation, ensure that the expansion valve regulates the overheating to its setpoint.
Alarm C2 communication EVD	Communication error to EVD 2 (expansion of valve control).	Ensure that there is no breakage of cables to EVD.
C3 communication EVD	Communication error to EVD 3 (expansion valve control).	Ensure that there is no breakage of cables to EVD.
C1 low suction temp	Low suction gas temperature.	Reset the alarm. In the event of recurring errors, contact authorised service personnel.
Offline cpcoe1	No communication between Carel c.pco and Carel c.pcoe.	Ensure that c.pcoe is energised (communication cable is connected to both Carel c.pco and Carel c.pcoe).
C1 Exhaust air battery pressure sensor failure	Interruption or short circuit to pressure sensor for exhaust air battery.	Ensure that c.pcoe and sensors are working and that there are no breaks in the cables.
C1 Exhaust air battery pressure sensor failure	Interruption or short circuit to pressure sensor for exhaust air battery.	Ensure that c.pcoe and sensors are working and that there are no breaks in the cables.
C1 Expansion line temp sensor fault	Interruption or short circuit to temperature sensor for expansion line.	Ensure that c.pcoe and sensors are working and that there are no breaks in the cables.

Alarm code	Possible cause	Measure
C1 RCP1 Heat PmpDwnT-mOut	The compressor has been pumping refrigerant to the condenser for longer than 240 seconds.	Ensure that the neutral conductor is connected, that the compressor is rotating and building up pressure, and that closed valves are sealed.
C1 ECP1 Heat PmpDwnTmOut	The compressor has been pumping refrigerant to the condenser for longer than 240 seconds.	Make sure the neutral conductor is connected, the compressor is rotating and building pressure, and closed valves are sealed.
C1 RCP1 Cooling PmpDwnT-mOut	The compressor has been pumping refrigerant to the condenser for longer than 240 seconds.	Make sure the neutral conductor is connected, the compressor is rotating and building pressure, and closed valves are sealed.
Refrigerant leakage, supply air	Refrigerant has been detected at the reversible heat pump's supply air coil.	The AHU's (air handling unit's) fans will automatically start provided that the 'Service Switch' is in the 'Auto' position.
Refrigerant leakage, extract air	Refrigerant has been detected at the reversible heat pump's extract air coil.	The AHU's (air handling unit's) fans will automatically start provided that the 'Service Switch' is in the 'Auto' position.
Alarm detector supply air, Busoffl	No communication with the detector.	Check/replace detector.
Detector alarm, extract air, Busoffl	No communication with the detector.	Check/replace detector.

6.3 Alarm Control system cooling unit/heat pump



Leak checks and replacement of parts in the refrigerant circuit must be carried out by a certified refrigeration technician. See "[1.11 Handling of refrigerant](#)", page 10.

Alarm code	Possible cause	Measure
AL 59 Compr 1, Low Cond Temp"	Too low condensing temperature due to too low extract air temperature or too low extract air flow or skewed flows.	Ensure that the extract air is at the correct temperature and that the air flows are correct.
76 Drive MainsPhaseLoss	The incoming phase to the frequency inverter is missing.	Check that all three phases are connected to the frequency inverter.
81 Drive U_phaseLoss	There is no phase between the frequency inverter and the compressor.	Check that all three phases are connected to the frequency inverter.
82 Drive V_phaseLoss	There is no phase between the frequency inverter and the compressor.	Check that all three phases are connected to the frequency inverter.
83 Drive W_phaseLoss	There is no phase between the frequency inverter and the compressor.	Check that all three phases are connected to the frequency inverter.
94 Drive offline	No communication with the frequency inverter.	Check that the frequency inverter is energised with 3-phase 400V.
94 Drive offline	Supply voltage missing.	Connect supply voltage (3x400 V).
118 Compr 1, Low evaporation pressure	Low evaporation temperature or low pressure in circuit 1.	Ensure that there are no leaks in the cooling circuit.



Order portal

Operation and maintenance Envistar Top

Alarm code	Possible cause	Measure
120 Compr 1, Low pressure diff.?"	No pressure difference between high pressure and low pressure side.	Contact a service technician.
121 Compr 1, High pressure switch	High pressure switch tripped in circuit 1.	Ensure that the airflow is correct and that the fire damper is working.
172 Compr 2, Motor protector	Circuit 2, motor protector alarm There is no phase between the frequency inverter and the compressor.	Check that all three phases are connected to the frequency inverter.
173 Compr 3, Motor protector	Circuit 3, motor protector alarm There is no phase between the frequency inverter and the compressor.	Check that all three phases are connected to the frequency inverter.
174 Compr 2, High pressure switch	Circuit 2, high pressure switch tripped.	Ensure that the airflow is correct and that the fire damper is working.
175 Compr 3, High pressure switch	Circuit 3, high pressure switch tripped.	Ensure that the airflow is correct and that the fire damper is working.
176 Compr 2, LowEvapPressure	Low evaporation temperature or low pressure in circuit 2.	Ensure that there are no leaks in the cooling circuit.
177 Compr 3, LowEvapPressure	Low evaporation temperature or low pressure in circuit 3.	Ensure that there are no leaks in the cooling circuit.
180 Compr 1, High pressure switch	High pressure switch tripped in circuit 1.	Ensure that the airflow is correct and that the fire damper is working.
183 AL_ C1_4wayRevValve	Four-way valve in wrong position	Contact a service technician.
189 Phase rotation order	Incorrect phase sequence for supply voltage on compressor 2	Shut off voltage and switch two of the incoming phases
190 Exhaust Air LowEvap-Frost-Protec	The evaporator is at risk of freezing due to too low an extract air temperature or too low an extract air flow or skewed flows.	Ensure that the extract air is at the correct temperature and that the air flows are correct.
228 Offline c.pcoe I/O	No communication between Carel c.pco and Carel c.pcoe.	Ensure that c.pcoe is energised and that the communication cable is connected to both Carel c.pco and Carel c.pcoe.
233 AI C1 PumpDownHtgRet-TimeOut	The compressor has been pumping refrigerant to the condenser for longer than 240 seconds.	Make sure the neutral conductor is connected, the compressor is rotating and building pressure, and closed valves are sealed.
234 AI C1 PumpDownHtgEx-hTimeOut	The compressor has been pumping refrigerant to the condenser for longer than 240 seconds.	Make sure the neutral conductor is connected, the compressor is rotating and building pressure, and closed valves are sealed.
235 AI C1 PumpDownClgRet-TimeOut	The compressor has been pumping refrigerant to the condenser for longer than 240 seconds.	Make sure the neutral conductor is connected, the compressor is rotating and building pressure, and closed valves are sealed.
255 AI TCR C1 SensorReturnAirCoilPressure	Interruption or short circuit to pressure sensor for exhaust air battery.	Ensure that c.pcoe and sensors are working and that there are no breaks in the cables.
256 AI TCR C1 SensorExhaustAirCoilPressure	Interruption or short circuit to pressure sensor for exhaust air battery.	Ensure that c.pcoe and sensors are working and that there is no breakage of cables.
257 AI TCR C1 SensorReturnAirCoilPressure	Interruption or short circuit to temperature sensor for expansion line.	Ensure that c.pcoe and sensors are working and that there are no breaks in the cables.

6.4 Fire alarm (fire damper, fire fan)



WARNING!
Risk of life-threatening or serious personal injury.
Added oxygen to the unit can spread the fire. The unit may be hot.

- If a fire is suspected in the unit:
 - Do not open the door.
 - Call emergency services.
- Use caution when touching the unit surfaces/doors.

00356

Alarm code	Possible cause	Measure
Fire alarm	Central fire alarm Smoke/fire in the unit, duct, or in the building.	If a fire is suspected, call emergency services.
Fire alarm temp Extract air / Supply air	> 40 °C in extract air or > 50 °C in supply air. Increased temperature due to hot water in heating water line or fire in unit/duct.	Make sure there is no fire. If there is no fire, but the duct detectors shine red, reset the detectors manually. Make sure that the air heaters are working properly.
Fire damper in wrong position	Fire damper open when it should be closed or vice versa.	Adjust fire damper.
Fire fan - no feedback	Pressure hoses incorrectly connected.	Make sure the pressure line is in the duct.
Fire damper feedback	Fire damper is in incorrect position.	Adjust damper.

6.5 Alarm filter

Alarm code	Possible cause	Measure
Filter alarm, fire	Clogged filters or smoke /fire in filters.	Make sure there is no fire.
Filter alarm	Clogged or incorrectly installed filters.	Change the filter or correct the filter.



Operation and maintenance Envistar Top

6.6 Temperature/cooling/freeze protection alarm

Alarm code	Possible cause	Measure
Freeze protection alarm	Incorrect operation of the circulation pump, heat exchanger or heating valve/actuator.	Check alarms on the circulation pump display.
	Non-continuous water flow through the coil due to air in coils, leakage or freezing.	Make sure that the hot water pipes are hot.
Alarm cooling	Cooling circuit error.	See separate Operation and Maintenance instructions for the cooling unit.
Temp deviations	Incorrect functioning of the heat exchanger or of the additional heating coil (internal or external) or of the cooling unit.	See the relevant section of this manual.
	Incorrectly set temperature values.	Adjust the set values.
Tempdiff. heating	Unexpected temperature difference: supply air sensor (GT1)/ supply air sensor energy recovery (GT6).	Ensure that the heating valve is not leaking or is manually set to the open position.

6.7 Other alarms

Alarm code	Possible cause	Measure
Modbus alarm	Quick connectors incorrectly connected.	Switch quick connectors.
Communication _damper _sensor module _air supply fan _extract air fan _heat recovery	No communication between Climatix and modbus connected device.	Connect quick connectors between unit parts.
Sensors _Not inc. _-252 °C	Sensor defective or incorrectly connected.	Ensure correct function. Replace faulty sensor.
Not config. IO	Configuration incorrectly completed (saved).	Exit and save configuration.

7 TROUBLESHOOTING

Area	Wrong	Reason	Measure
Residual current circuit breaker Fuses Electricity	No unit power.	Tripped residual current circuit breaker/fuse. Supply not connected.	Ensure connected supply and installed residual current circuit breaker (300 mA). Ensure fuses are on and properly installed for rated current. Troubleshoot by turning all fuses off and on one at a time. If fuse or residual current circuit breaker trip, contact a licenced electrician.
	Black display.	Display not connected. Voltage supply not functioning.	Make sure the cable is connected.
Water Drain Drainage	Water not draining from drip drums. No water in water traps.	Water trap incorrectly installed or clogged. Unit incorrectly positioned.	Ensure that the unit has the correct tilt on the inspection side. See also Assembly instructions for the AHU (air handling unit).
Energy use Heat transfer Air flow	Insufficient efficiency.	Malfunction rotary heat exchanger or in plate heat exchanger or in coil recovery or in air heater/air cooler.	See the relevant section of this manual.
	Reduced air flow.	Incorrect rotation direction of fan impeller. Pressure drop too high in the duct system.	Ensure correct rotation direction and that the flow measurement ring line and connected hoses are undamaged.
Odour transfer	Odour transfer between extract air and supply air.	Leakage between extract air and supply air (duct system, intake and exhaust hood, damper or louvre).	See relevant sections for heat exchangers and dampers.
Frost build-up Ice build-up	Frost or ice build-up on the heat recovery coil extract air.	The frost protection equipment not functioning correctly.	Contact service personnel for freeze protection sensor setting, function of the three-way valve and pump.
	Re-freezing in counter-flow heat exchangers.	Abnormally high moisture content in the extract air.	See BYP and ODS in the section " 5.10 Maintenance of counter-flow heat exchangers ", page 38 .
Overheating electric heater	Overheat protection tripped.	The electric heater is heavily contaminated or airflow is low.	Clean and reset. Check airflow against projected values and adjust if necessary.



8 DECOMMISSIONING AND RECYCLING



WARNING!

Risk of cutting.

Sharp edges can cause cuts.

- Use appropriate personal protective equipment when the work requires it.

00181



WARNING!

Risk of serious personal injury.

Contact with refrigerants can cause frostbite to the skin.

- Refrigerants and parts containing refrigerants may only be handled by persons with certificates in accordance with current EU regulations for refrigerants.
- Wear appropriate protective clothing.

00331



WARNING!

Risk of personal injury.

Contact with the oil can cause skin irritations.

- Draining oil from the compressor must only be carried out by certified persons in accordance with applicable EU regulations for refrigerants.
- Wear appropriate protective clothing.
- Wash hands and other body parts that have been in contact with the oil.

00330



WARNING!

Risk of inhalation of harmful particles.

When changing filters, particles, such as dust, may come loose from the used filter.

- Wear a protective mask when changing filters.
- Use caution when handling used filters.
- Thoroughly clean the filter cabinet after replacement as particulate matter may become loose and remain in the cabinet.

00325

8.1 Disposal and recycling

Disposal and recycling must take place in an environmentally safe manner in accordance with applicable regulations in the country where the product is being disposed of. Up to 90% of the material in the unit can be recycled.

8.2 Dismantling the AHU (air handling unit)



- Cooling unit/reversible heat pump and DX coils must be emptied of refrigerant by a certified cooling technician before disassembly. See separate Operation and Maintenance instructions for ThermoCooler HP and EcoCooler.
- Air heaters and air coolers must be drained of fluid (for example, glycol) before disassembly.
- Liquids may contain additives or contaminants and must be handled in accordance with applicable national and international environmental requirements.

1. Turn off all electricity and ensure that the unit is de-energised. See "[5.4 Switch off the unit before maintenance.](#)", page 26.
2. Remove covers, electrical components and filters.
3. Disassemble profiles and joints.
4. Remove hatches and remove interior insulation.
5. Sort and recycle according to current national regulations in the country where the unit is being disposed of.

8.3 Material content

For more specific information about materials, see the Building Product Declaration under Documentation on ivprodukt.docfactory.com or contact IV Produkt.

9 SERVICE SCHEDULE

For descriptions of different unit parts and their functions, refer to Functional Descriptions in Section "3 DESCRIPTION OF THE UNIT", page 56.

Service year:		Order no.:	Project name:			
Notes:			Service performed (date/signature)			
Unit part	Code	Check (see maintenance instructions in the sections below)	12 months	24 months	36 months	48 months
Filter	ETFL	"5.8 Filter maintenance", page 29				
Rotary heat exchanger	TER, TXR	"5.9 Maintenance of rotary heat exchanger", page 31				
Counter-flow heat exchanger	TEM, TXM	"5.10 Maintenance of counter-flow heat exchangers", page 38				
Fan	ELFF	"5.11 Fan maintenance", page 40				
Air heater water	ETAB-VV ETAB-TV SBC-VV	"5.12 Maintenance of air heater/air cooler water", page 42				
Air cooler water	ETKB-VK SBK-VK	"5.12 Maintenance of air heater/air cooler water", page 42				
Air heater electric	ETAB-EV ETAB-SV ETKB-EV	"5.13 Maintenance of air heater electric", page 44				
Damper	ETSP-UM ETSP-TR ETRL	"5.15 Damper maintenance", page 45				
Sound attenuator	ETLD	"5.16 Sound attenuator maintenance", page 46				
Reversible heat pump	TTC TTCH	"5.14 Maintenance of refrigerant circuit", page 45				
Cooling unit	TEC TECO TECX	"5.14 Maintenance of refrigerant circuit", page 45				

Feel free to contact us



IV Produkt AB, Sjöuddevägen 7, S-350 43 VÄXJÖ
+46 470 – 75 88 00
www.ivprodukt.se, www.ivprodukt.com
www.ivprodukt.no, www.ivprodukt.dk, www.ivprodukt.de



Support:

Control: +46 470 – 75 89 00, styr@ivprodukt.se
Service: +46 470 – 75 89 99, service@ivprodukt.se
Spare parts: +46 470 – 75 86 00, reservdelar@ivprodukt.se
DU/Documentation: +46 470 – 75 88 00, du@ivprodukt.se

For support, enter the Order Number.

Order number:

Project name:
