Operation and Maintenance

EcoCooler 100-1280



Order number:
Project name:



Table of Contents

1	Safety precautions	
1.1	Personal protective equipment	1
1.2	Prevent injury to personal and damage to air handling units	1
1.3	Product signs, information and warning stickers	2
1.4	Safety message	2
1.5	General safety messages	3
2	General	
2.1	Intended use	6
2.2	Manufacturer	6
2.3	Designations	7
2.4	CE marking and EU Declaration of Conformity	8
2.5	Maintenance	8
2.6	Handling of refrigerant	9
2.7	Extended warranty	11
2.8	Spare parts	11
2.9	Dismantling and decommissioning	11
3	Technical description	
3.1	Cooling unit, EcoCooler	12
3.2	Detector system, refrigerant	13
4	Wiring instructions	
4.1	Electrical connections, ECO and ECX cooling units	17
5	Operation	
5.1	Commissioning	18
5.2	Cooling status	19
6	Maintenance instructions	
6.1	Service schedule	21
6.2	Periodic inspection	21
7	Alarm management and troubleshooting	
7.1	Troubleshooting in the event of an alarm	22
7.2	Troubleshooting via symptoms	24



1 Safety precautions

Follow all safety precautions in this document and pay attention to all warning signs on the air handling unit.

Failure to comply with the safety precautions may result in injury to persons or damage to air handling units.

1.1 Personal protective equipment

Personal protective equipment must always be used based on the risks present at the workplace. Comply with national and local laws and regulations.

The following personal protective equipment is recommended where the work requires:

- Protective shoes with steel cap
- Hearing protectors
- Safety helmet
- Gloves
- Goggles
- Covering clothing
- Protective overalls
- Mouthguard/protective mask
- Fall protection

1.2 Prevent injury to personal and damage to air handling units

To avoid injury to persons or damage to air handling units, pay attention to the following:





- Read the entire document before working on the unit.
- Comply with national and local laws and regulations for work safety.
- Do not wear loose clothing or jewellery that may get fasten.
- Do not step or climb on the unit.
- Use recommended tools and equipment intended for the job.
- Use recommended personal protective equipment when the work requires it.
- Observe the unit's product signs, information and warning stickers.
- Keep the unit clean and follow the Operation and Maintenance Instructions.
- Make sure that all covers are in place, that inspection covers are closed and that lockable inspection covers are locked before starting the unit and after repairs/service.
- Use appropriate fall protection when working at heights - normally over 2 meters. Even work at lower heights may require protective measures.

1.3 Product signs, information and warning stickers

Keep signs and stickers free from soiling and replace them if they are lost, damaged or illegible. Contact IV Produkt for replacement stickers; specify the item number.

1.4 Safety message

The following warning symbols and signal words are used in this document to inform of risks.

 DANGER!	Danger - indicates an imminent dangerous situation which, if not avoided, can result in death or serious injury.
 WARNING!	Warning - indicates a potentially dangerous situation which, if not avoided, can lead to serious injury.
 CAUTION!	Caution - indicates a less potentially dangerous situation which, if not avoided, can lead to less serious or minor injuries.
 NB:	NB: – indicates a potentially hazardous situation which, if not avoided, may result in damage or impaired function of the air handling unit.

1.5 General safety messages

Comply with the following general safety messages.

Lockable safety switch

	<p>DANGER! Risk of serious injury. Electrical power can cause electric shock, burns and death.</p> <p>Working on/servicing the unit – Shut down the unit via the service switch in the control equipment, then turn the safety switch to the 0 position and lock it.</p> <p>There may be several safety switches serving the different parts of the unit. All safety switches must be switched off before repairs/service.</p>
---	---

	<p>NB: The safety switch is not designed for starting/stopping the unit. Always use the service switch in the control equipment to start and shut down the unit.</p>
---	---

Electrical connections

	<p>DANGER! Risk of serious injury. Electrical power can cause electric shock, burns and death.</p> <p>Working on/servicing the unit – Shut down the unit via the service switch in the control equipment, then turn the safety switch to the 0 position and lock it.</p> <p>There may be several safety switches serving the different parts of the unit. All safety switches must be switched off before repairs/service.</p>
---	---

	<p>WARNING! Risk of personal injury. Rotating fan impellers can cause crushing injuries or lacerations. The unit must not be energised until all ducts have been connected.</p>
---	--

	<p>NB: Wiring of connections and other electrical work may only be carried out by a qualified electrician or by service personnel recommended by IV Produkt.</p>
---	---

Inspection hatches



WARNING!
Risk of personal injury.
Overpressure in unit.
Allow the pressure to drop before you open the inspection doors.



WARNING!
Risk of personal injury.
The doors in front of moving parts shall normally be locked; there are no contact guards.

During repairs/service, the inspection doors are locked with the supplied keys.

Make sure that all hatches are closed and that lockable inspection hatches are secured before starting the unit and after repairs/service.

Heating coil



WARNING!
Risk of personal injury.
Hot surfaces can cause burns.

Working on/servicing the unit – Shut down the unit via the service switch in the control equipment, then turn the safety switch to the 0 position and lock it.

There may be several safety switches serving the different parts of the unit. All safety switches must be switched off before repairs/service.

Wait at least 5 minutes before opening the battery inspection hatches.

Cooling unit



WARNING!

**Risk of personal injury.
Hot surfaces can cause burns.**

Working on/servicing the unit – Shut down the unit via the service switch in the control equipment, then turn the safety switch to the 0 position and lock it.

There may be several safety switches serving the different parts of the unit. All safety switches must be switched off before repairs/service.

Wait at least 30 minutes before opening the compressor inspection hatches.



WARNING!

Risk of fire in the event of a refrigerant leak.

A2L refrigerants are mildly flammable and can ignite in the event of a leak.

If external damage to the cooling circuit has led to a refrigerant leak, evacuate the ventilation room, ensure good ventilation, and call in a certified refrigeration technician.

Service of cooling units may only be carried out by a certified refrigeration technician. Working on/servicing the unit – Shut down the unit via the service switch in the control equipment, then turn the safety switch to the 0 position and lock it.

There may be several safety switches serving the different parts of the unit. All safety switches must be switched off and locked before repairs/service.

Due to the risk of sparks, safety switches must not be used if there is a suspected refrigerant leak.

When detector system installed:

- Make sure the detector system is functioning.**
- Make sure that external dampers in the ductwork do not block the unit's air flow through uncontrolled closing.**



2 General

2.1 Intended use

The EcoCooler cooling unit is designed to cool supply air in buildings (comfort cooling). The unit is designed to be installed together with IV Produkt AB air handling units.

When installed indoors, the unit must be installed in an area that maintains a temperature between +7 and +30°C, and with a moisture content of <3.5 g/kg in dry air in the winter. The unit can also be equipped for outdoor installation.

Any other use and installation in other environments are prohibited unless specifically permitted by IV Produkt AB.

It is not permitted to use the unit in potentially explosive environments, Eex.

Intended users

The contents of this manual are intended for personnel who commission and carry out regular maintenance on the unit. Maintenance and servicing of the cooling unit must be carried out by a certified refrigeration technician.

2.2 Manufacturer

The EcoCooler cooling unit is manufactured by:

IV Produkt AB
Sjöddevägen 7
S-350 43 VÄXJÖ

2.3 Designations

The EcoCooler comes with a model rating plate placed on the front.

The model type plate shows the series number and the requisite designations to identify the unit.

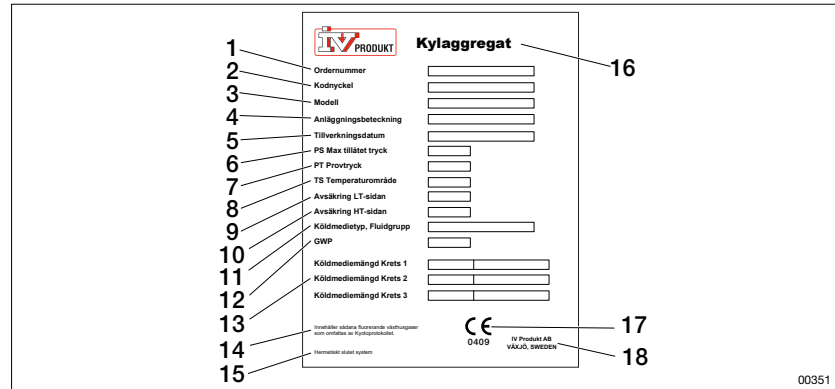

Example of a cooling unit type plate

- | | |
|--|---|
| 1. Order number | 10. Refrigerant type, Fluid Group |
| 2. Code key | 11. GWP |
| 3. Model | 12. Refrigerant volume, Circuit 1, 2, 3 (kg, CO ₂ e) |
| 4. Plant designator | 13. Contains fluorinated greenhouse gases controlled by the Kyoto Protocol. |
| 5. Date of manufacture | 14. Hermetically sealed system. Applies to refrigerants R410A and R454B (not available for Easy Access) |
| 6. PS Max allowed pressure, bar (e) | 15. Cooling unit |
| 7. PT Pressure test, bar (e) | |
| 8. TS Temperature range, °C | |
| 9. Fuse protection LT/HT side, bar (e) | |

2.4 CE marking and EU Declaration of Conformity

The cooling unit is CE-marked, which means that upon delivery, it conforms to applicable provisions in the EU Machinery Directive 2006/42/EC as well as to the EU Directives applicable to the type of unit, e.g. Pressure Equipment Directive.

As certification confirming that the requirements have been met, we provide an EU Declaration of Conformity, which is available under Documentation at ivprodukt.docfactory.com, or under Order Unique Documentation at docs.ivprodukt.com.

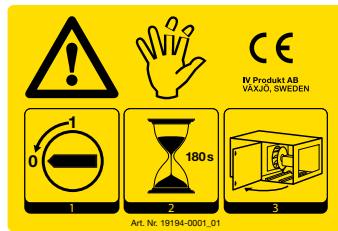

Typical CE label for air handling units

For units without integrated control equipment

The EC declaration applies only to units in the condition in which they have been delivered and installed at the facility in accordance with the enclosed installation instructions. The declaration does not include components that were subsequently added or measures subsequently taken on the unit.

2.5 Maintenance

Maintenance and servicing of the cooling unit must be carried out by a certified refrigeration technician.

2.6 Handling of refrigerant

The following information summarises the requirements and guidelines for handling the refrigerant used in cooling units. For further information, see the F-gas Regulations and the National Refrigerant Handling Regulations.

Responsibility

The physical or legal person (also referred to as ‘operator’) exercising actual responsibility over the technical functioning of the equipment and systems covered by the F-gas Regulation. The operator is usually the owner of the system.

Operator responsibilities:

- Minimise and prevent leakage
- Take corrective action to remedy any leakage that arises
- Ensure that leak inspection, service and repair of the refrigerant circuit are carried out by a certified refrigeration technician
- Ensure that refrigerant is handled in an environmentally safe manner and in accordance with national regulations.

Use and inspection of pressurised equipment

Inspection must be carried out in accordance with the applicable national legislation.

Leakage control and registration



Leakage control must be carried out by a certified refrigeration technician.



Different countries may have different regulations regarding leakage control and record keeping.

Leakage control and record keeping must be carried out in accordance with national applicable regulations.

Refer to the unit’s type plate for refrigerant type, refrigerant quantity, and carbon dioxide equivalent.

All units with refrigerant R410A or R454B are classified as hermetically sealed.

Size	Refrigerant	Leakage control		Register administration
		Assembly leak detection	Every 12 months	In case of control/intervention
100	R410A	-	-	-
	R454B	-	-	-
150	R410A	Yes ¹	-	-
	R454B	-	-	-
190	R410A	Yes ¹	-	-
	R454B	-	-	-
240	R410A	Yes ¹	-	-
	R454B	-	-	-
300	R410A	Yes	Yes	Yes
	R454B	-	-	-
360	R410A	Yes	Yes	Yes
	R454B	-	-	-
400	R410A	Yes	Yes	Yes
	R454B	-	-	-
480	R410A	Yes	Yes	Yes
	R454B	-	-	-
600	R410A	Yes	Yes	Yes
	R454B	-	-	-
740	R410A	Yes	Yes	Yes
	R454B	-	-	-
850	R410A	Yes	Yes	Yes
	R454B	Yes ^{1, 2}	-	-
980	R410A	Yes	Yes	Yes
	R454B	Yes ^{1, 2}	-	-
1080	R410A	Yes	Yes	Yes
	R454B	Yes ^{1, 3}	-	-
1280	R410A	Yes	Yes	Yes
	R454B	Yes ^{1, 3}	-	-

¹ Applicable in Sweden.

² Applies to output variant 1.

³ Applies to output variants 2 and 3.

2.7 Extended warranty

In cases in which the equipment delivered is covered by a 5-year warranty, in accordance with ABM 07 with appendix ABM-V 07 or in accordance with NL 17 with appendix VU20, the IV Produkt Service and Warranty Manual is supplied with the product.

In order to claim an extended warranty, a complete, documented and signed IV Produkt Service and Warranty Manual must be presented.

2.8 Spare parts

Spare parts and accessories for this unit can be ordered from IV Produkt's nearest dealership. When ordering, the order number and designation must be given. These are stated on a model identification label, affixed to each functional section.

There is a separate spare parts list for the unit, refer to Order Unique Documentation at docs.ivprodukt.com.

2.9 Dismantling and decommissioning

When an air handling unit is to be dismantled, separate instructions must be followed, see [Dismantling and decommissioning the AHU](#) under Documentation at ivprodukt.docfactory.com.

3 Technical description

3.1 Cooling unit, EcoCooler



*Fan and filter section
(extract air fan)*

*EcoCooler cooling unit
(with cooling recovery, code ECX)*

*Fan and filter section
(supply air fan)*

EcoCooler is a range of integrated speed controlled cooling units with stepless cooling power.

Two different versions of EcoCooler are available:

- without cooling recovery (without rotary heat exchanger), code ECO
- with cooling recovery (with rotary heat exchanger), code ECX. Cooling recovery means that the thermal wheel starts up when the extract air/room temperature drops below the outdoor temperature and cooling is required.

Cooling units with R454B refrigerant are equipped with integrated control equipment (code MX).

3.2 Detector system, refrigerant

Cooling units with refrigerant R454B are equipped as standard with detectors to detect refrigerant leaks. An exception applies to Size 100, where the detector equipment is available as an optional extra. For units with refrigerant R410A, the detector equipment is available as an optional extra.

To guarantee approved dilution in the event of a refrigerant leak, ensure that the air volumes are greater than the unit's specified minimum air flow, both on the supply air side and extract air side (see docs.ivprodukt.com - Technical data).

In the event of a refrigerant leak, the installed detector system ensures that the minimum permissible air flow is always achieved, which dilutes the refrigerant to an approved level.

For leak detection and ventilation to work effectively, the unit must have power and the service switch must remain in the 'Auto' position at all times after installation, except during work/servicing.

If the detector triggers a leak alarm, the unit's fans are started to dilute the refrigerant to an approved level, and an alarm notification is shown on the Climatix display.

Should a detector be non-functional, an alarm is triggered and the air handling unit is kept running until the fault is rectified.

In the event of an alarm, correct the fault and then reset the alarm.

If necessary, call a certified refrigeration service with the necessary knowledge of handling and maintaining equipment with refrigerants.

Cooling circuit function

A cooling system has four basic components: evaporator, condenser, expansion valve and compressor.

The compressor carries out the work required to run the cooling process.

The evaporator is located in the supply air for the unit. The heat from the outdoor air is taken up in this coil, thereby cooling the supply air.

The energy supplied to the cooling system from the evaporator and the compressor leaves the unit via the condenser. The condenser is located in the extract air (ECO) or the exhaust air (ECX). This means that the exhaust air becomes hot when the cooling unit is running.

It is important to ensure that the air volumes are above the specified minimum flow on both the outdoor air and extract air side. The process cannot work if these air volumes are not available.

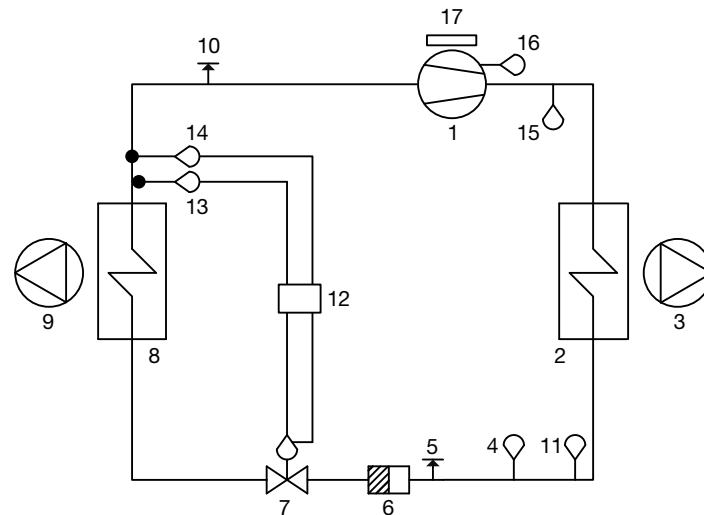

Flow chart for EcoCooler refrigerant system

1 Compressor	10 Measurement outlets – low pressure
2 Condenser	11 Liquid line sensor
3 Extract air fan	12 Control unit
4 Pressure switch – high pressure	13 Temperature sensor suction gas
5 Measurement outlet – high pressure	14 Pressure sensor – low pressure
6 Drying filter	15 Hot gas sensor
7 Expansion valve	16 Temperature sensor sump
8 Evaporator	17 Frequency inverter
9 Supply air fan	

Compressor

EcoCooler is equipped with a speed-controlled PM scroll compressor. Depending on its size, the unit may be equipped with one or two additional fixed compressors.

When cooling is required, the frequency inverter increases the speed of the compressor.

If the EcoCooler is equipped with two or more compressors, the fixed compressors will engage when the speed-controlled compressor has reached its maximum speed. The speed-controlled compressor returns to its minimum speed and can then adjust back up to maximum speed. This achieves infinitely adjustable cooling power.

The function is reversed where less cooling is needed.

Compressor protection

In the event of an alarm initiated by the control equipment or the high pressure switch, the compressor stops and an alarm indication is given. If the unit is equipped with integrated control equipment, the alarm can be read on the Climatix display.

In the event of an alarm, correct the fault and then reset the alarm. If the high pressure alarm trips repeatedly, an authorised refrigeration service company must be called in.

The high pressure switch is tripped when the system is at high pressure and has a manual reset button. To avoid accidental stoppages at high pressure, the unit will lower the power using the high pressure sensor.

Cooling function

For internal control (MX), the cooling unit is interlocked across the air handling unit. If any of the fans stop, the cooling unit will also stop. The interlock and demand signal is sent via Modbus.

For external control (US, UC and MK), the interlock signal must be sent via a potential-free relay. The demand signal must be sent via 0–10 V.

Circuit board

The circuit board for the cooling unit contains the following:

- Main switch
- Fuse
- Control unit with integrated control for expansion valve next to speed controlled compressor
- Control unit for expansion valve next to fixed speed compressor

The circuit board is installed inside the unit and is internally prewired and tested at the factory.

Current limiting

The control unit for EcoCooler is equipped with a function that measures the cooling unit's power consumption. The power consumption can be limited to an adjustable value. If the unit is connected to a fuse that is less than the one recommended in Chapter 3, this function should be used.

To activate the function, do the following in the control unit:



1. Press the circle button.
2. Press the down arrow to highlight "Status – I/O".
3. Press the enter arrow button.
4. Press the up arrow to access the "Current limit" menu.
5. Press the enter arrow button so that the cursor starts flashing.
6. Press the up arrow to change "NO" to "YES".
7. Press the enter arrow button so that the cursor starts flashing on the row below.
8. Use the up/down arrows to set the fuse size.
9. Press the enter arrow button.
10. Press the back arrow button twice to return to the start menu.

4 Wiring instructions

For connection instructions for an associated electrical air heater, refer to the separate wiring diagram under Order-specific Documentation at docs.ivprodukt.com.

For connection instructions for the rotary heat exchanger, refer to Operation and Maintenance under Order-specific Documentation at docs.ivprodukt.com.

4.1 Electrical connections, ECO and ECX cooling units

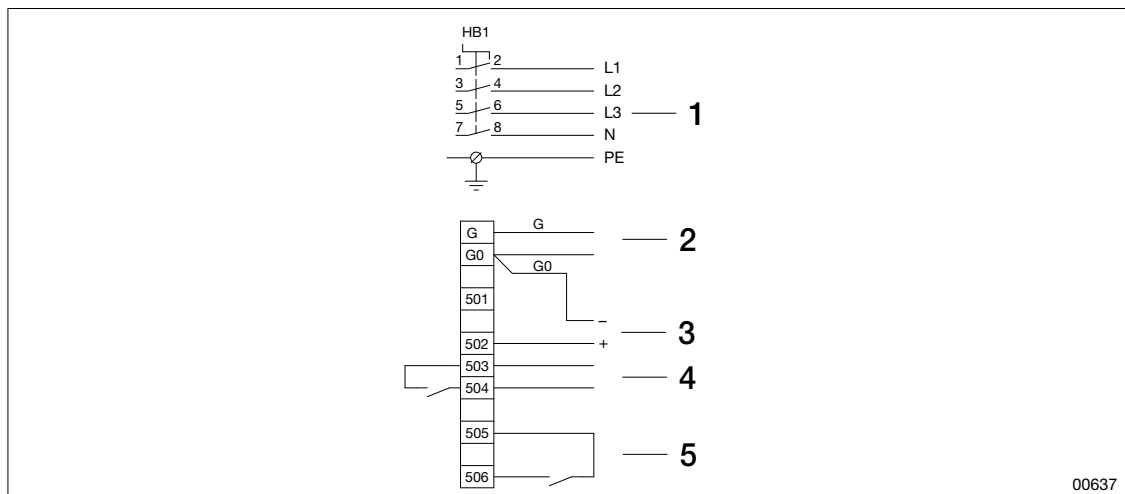

Figure: Electrical diagram, size 100-980

- | | |
|-----------------------------|---|
| 1. POWER SUPPLY 3×400V~50Hz | 4. ALARM, COMPRESSOR (CLOSES IN EVENT OF ALARM) |
| 2. POWER SUPPLY 24 V~ | 5. INTERLOCK, FROM SF AND EF |
| 3. CONTROL 0-10 V= | |

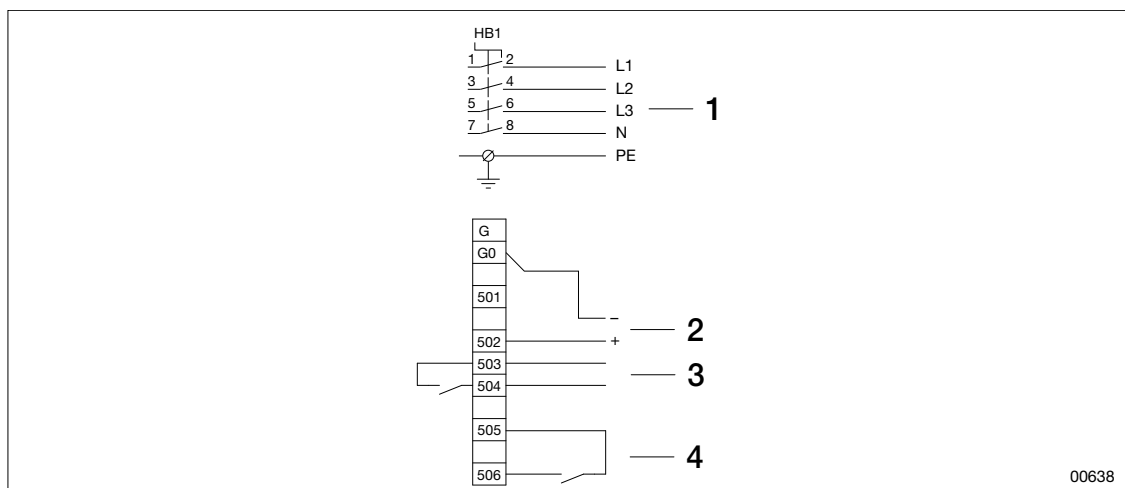

Figure: Electrical diagram, size 1080 och 1280

- | | |
|-----------------------------|---|
| 1. POWER SUPPLY 3×400V~50Hz | 3. ALARM, COMPRESSOR (CLOSES IN EVENT OF ALARM) |
| 2. CONTROL 0-10 V= | 4. INTERLOCK, FROM SF AND EF |

5 Operation

5.1 Commissioning

Commissioning of the cooling unit must be carried out by qualified personnel in accordance with the Commissioning Record, which can be downloaded at docs.ivprodukt.com or ivprodukt.docfactory.com.

The Commissioning Record applies to units that are supplied with control equipment (code MX).

The validity of the product warranty is conditional on the system having been commissioned correctly. Working on the cooling unit during the warranty period without the approval of IV Produkt shall render the warranty void.

Prior to commissioning, the contractor must:

	<p>DANGER! Risk of serious personal injury and/or damage to air handling unit. Read and understand the entire chapter "1.5 General safety messages" before working on, servicing, or inspecting the air handling unit.</p>
---	---

	<p>NB! Risk of compressor damage. The oil in the speed-controlled compressor must be warm before commissioning. The cooling unit must be powered up for at least 8 hours before commissioning.</p>
---	---

1. Connect the unit to the power supply via a lockable safety switch.
2. Connect all ducts.
3. For cooling units with refrigerant R454B – make sure that external dampers communicate with the unit's control equipment so that the air flow through the unit cannot be blocked uncontrollably.

Follow the troubleshooting instructions in the troubleshooting chart before contacting a service representative for servicing a unit under warranty. This will prevent any unnecessary service calls.

5.2 Cooling status

Status information is read on the Climatix display.

Information	Value	Explanation
Regulator	x %	Cooling regulator output signal.
Cooling output signal	x %	Cooling load from Climatix to Carel.
Status Cooling machine		Status of cooling unit
Status HP		Heat pump operation status.
Settings	>	Settings for blocking operation.
DX cooling	Off/step 1	
Alarm		The alarm is displayed if there is a fault with the inverter or compressor. In the event of an alarm, see "Alarm information for inverter and compressor" page 23.

Compressor C1	On/Off	Compressor operating mode.
Suction gas temp C1	x.x°C	Measured suction gas temp.
Evaporation temp C1	x.x°C	Calculated evaporation temp based on low pressure.
Low pressure C1	x.x bar	Relative pressure from low pressure sensor.
Overheating C1	x.x K	Measured overheating.
High pressure C1	x.x bar	Relative pressure from high pressure sensor.
Expansion valve 1	x %	Expansion valve position.
Condensation temp C	x.x°C	Calculated condensation temperature based on high pressure.
Hot gas temperature	x.x °C	Output temperature from compressor.
Liquid line temperature	x.x °C	Temperature after condenser.
Supercooling	x.x °C	Measured supercooling.



Cooling unit with detector system

Status information is read on the Climatix display.

Information	Value/example	Explanation
Supply air		
Refrigerant leakage	Normal	Leak alarm information
Detector alarm	Normal	Detector alarm information
Concentration LFL	0.0 %	Current measured refrigerant concentration
Temperature chip	22.2 °C	Internal detector temperature
Heater temperature	25.0 °C	Internal detector heater temperature
FW Version	1.0	Detector software version
Sensor ID	54291003	Detector identification number
Extract air		
Refrigerant leakage	Normal	Leak alarm information
Detector alarm	Normal	Detector alarm information
Concentration LFL	0.0 %	Current measured refrigerant concentration
Temperature chip	23.5 °C	Internal detector temperature
Heater temperature	25.0 °C	Internal detector heater temperature
FW Version	1.0	Detector software version
Sensor ID	54291211	Detector identification number
Calibrate detector		Function to calibrate or test the detector
Calibration status supply air	OK	Calibration information
Calibration status extract air	OK	Calibration information

6 Maintenance instructions

6.1 Service schedule

For a service schedule, see Operation and Maintenance for Envistar Flex or Flexomix, under Order-specific Documentation at docs.ivprodukt.com.

6.2 Periodic inspection

The operation parameters for the cooling unit must not be changed unless a check is first made to ascertain that the changes will be within the unit's operating range.

Leakage inspection and registration

For information on the operator's responsibility with regards to leakage inspection and registration, see "2.6 Handling of refrigerant" page 9.

Visual check



DANGER!
Risk of serious personal injury and/or damage to air handling unit.
Read and understand the entire chapter "1.5 General safety messages" before working on, servicing, or inspecting the air handling unit.

Check:

- The fins on the condenser and evaporator to detect mechanical deformations.
- The drip tray and drain with water trap (clean if necessary).
- That the water trap (without non-return valve) is filled with water.
- That the non-return valve in a water trap with a non-return valve closes tightly.

Cleaning



DANGER!
Risk of serious personal injury and/or damage to air handling unit.
Read and understand the entire chapter "1.5 General safety messages" before working on, servicing, or inspecting the air handling unit.

If the fins on the condenser and evaporator are fouled, they should be vacuumed from the inlet side. Alternatively, they can be blown clean with compressed air from the outlet side. In the event of heavy soiling, you can clean them with warm water mixed with dishwashing detergent that does not corrode aluminium.

For more information, refer to [Cooling coil, cleaning](https://docs.ivprodukt.com) under Documentation at ivprodukt.docfactory.com.

Function

Check that the cooling unit operates as it should by temporarily lowering the temperature setting (setpoint).

Refrigerant detectors

The detectors are self-calibrating and do not require set-up or maintenance.

7 Alarm management and troubleshooting

For units with control equipment (code MX), alarm information can be read on the Climatix display. For units without control equipment (code UC, MK, US), alarm information can be read on the Carel display. Press the alarm symbol to view alarms.

7.1 Troubleshooting in the event of an alarm

Inspection	Possible cause	Corrective action
Is the alarm "94 Drive offline" displayed?	YES The frequency inverter does ⇒ not have supply voltage 3×400V.	Connect the supply voltage to the frequency inverter. Check fuses. Check cabling for communication between frequency inverter and Carel
NO ↓		
Has the high pressure switch tripped? Is the alarm "121 Compr 1, High pressure switch" or "180 Compr 1, High pressure switch" displayed?	YES No or too low air flow across ⇒ the condenser Defective high pressure switch.	Check the air flow across the condenser. Reset the pressure switch manually. Check/replace. Call a certified refrigeration service.
NO ↓		
Is alarm "118 Compr 1, Low evaporation pressure" or "176 Compr 2, LowEvapPressure" or "177 Compr 3, LowEvapPressure" displayed?	YES Insufficient refrigerant volume ⇒ No air flow or too low air flow across the evaporator. Defective expansion valve or low pressure control.	Look for leakage, seal the leak and top up with refrigerant. Check/adjust the flow. Check/replace. Call a certified refrigeration service.
NO ↓		
Is the LED flashing red on the frequency inverter?	YES Phase failure/voltage drop. ⇒ Overload/defective variable-speed compressor.	Check the 3-phase supply, measure the incoming voltage. Reset the frequency inverter by switching off the voltage for 1 minute or more. Check that the compressor is running without dissonance. Reset the frequency inverter by switching off the voltage for 1 minute or more. Check that the compressor is running without dissonance.
NO ↓		
Is the alarm "189 Phase Rotation order" displayed?	YES Incorrect phase sequence ⇒ for supply voltage on compressor 2	Shut off voltage and switch two of the incoming phases
NO ↓		
Is the alarm "AL 120 Compr 1 Low pressure diff." displayed?	YES No pressure difference ⇒ between the high-pressure and low-pressure side.	Contact service.
NO ↓		
Is the alarm "AL 59 Compr 1 Low Cond Temp" displayed?	YES Condensing temperature too ⇒ low.	Contact service.

Alarm information for inverter and compressor

Alarm Climatix	Explanation and corrective action
Cooling unit	
Sum alarm	Sum alarm, check alarm in Carel, see table below.
Alarm C1 R. pressure switch	High pressure switch tripped or alarm for frequency inverter.
Alarm C1 EEV motor fault	Fault on electrical connection to expansion valve.
Alarm C1 low pressure sensor	Power cut or short circuit to low pressure sensor. Check EVD, cabling and sensor.
Alarm C1 suction gas sensor	Power cut or short circuit to suction gas sensor. Check EVD, cabling and sensor.
Alarm C1 high pressure sensor	Power cut or short circuit to high pressure sensor. Check EVD, cabling and sensor.
Alarm C1 low overheating	Compressor stoppage caused by low overheating.
Alarm C1 LOP	Compressor stoppage caused by low evaporation temperature.
Alarm C1 MOP	Compressor stoppage caused by high evaporation temperature.
Alarm C2 communication EVD	Communication error to EVD 2 (expansion valve control).
Alarm C3 communication EVD	Communication error to EVD 3 (expansion valve control).
Alarm C1 low suction gas temp	Low suction gas temperature.
Refrigerant leakage, supply air	Refrigerant has been detected at the cooling unit's supply air coil. The unit's fans will automatically start provided that the 'Service Switch' is in the 'Auto' position.
Refrigerant leakage, extract air	Refrigerant has been detected at the cooling unit's extract air coil. The unit's fans will automatically start provided that the 'Service Switch' is in the 'Auto' position.
Detector alarm, supply air, Busoffl	No communication with detector.
Detector alarm, extract air, Busoffl	No communication with detector.

Alarm Carel	Explanation and corrective action
76 Drive MainsPhaseLoss	Check that all three phases are connected to the frequency inverter.
81 Drive U_phaseLoss	
82 Drive V_phaseLoss	
83 Drive W_phaseLoss	
94 Drive offline	No communication with the frequency inverter. Check that the frequency inverter is energised with 3-phase 400V.
118 Compr 1, Low evaporation pressure	Circuit 1, low evaporation temp/pressure. Check leakage in cooling circuit.
121 Compr 1, High pressure switch	Circuit 1, high pressure switch tripped. Check air flow.
172 Compr 2, Motor protector	Circuit 2, motor protector alarm.
173 Compr 3, Motor protector	Circuit 3, motor protector alarm.
174 Compr 2, High pressure switch	Circuit 2, high pressure switch tripped. Check air flow.
175 Compr 3, High pressure switch	Circuit 3, high pressure switch tripped. Check air flow and fire damper.
176 Compr 2, LowEvapPressure	Circuit 2, low evaporation temp/pressure. Check leakage in cooling circuit.
177 Compr 3, LowEvapPressure	Circuit 3, low evaporation temp/pressure. Check leakage in cooling circuit.
180 Compr 1, High pressure switch	Circuit 1, high pressure switch tripped. Check air flow.
189 Phase rotation order	Incorrect phase sequence gives incorrect rotation direction. Switch two of the incoming phases.



7.2 Troubleshooting via symptoms

Symptom	Possible cause	Corrective action
Low cooling power - too high temperature in the cooled object	The power supply has been interrupted.	Check the control/safety switches and fuses.
	No air flow or too low air flow across evaporator.	Check that nothing is inhibiting the air flow.
	The control equipment is incorrectly preset/defective	Adjust the settings or replace the equipment.
Compressor is not operating	The power supply has been interrupted.	Check the control/safety switches and fuses.
	The compressor has tripped the high pressure switch.	Check and reset, if needed.
	Defective compressor	Check/replace. Call a certified refrigeration service.
Frost on the evaporator	The expansion valve is incorrectly preset/defective	Check/replace. Call a certified refrigeration service.
	Insufficient refrigerant volume	Search to detect leakage, seal the leak and charge with refrigerant Call a certified refrigeration service.
	Low supply air flow.	Adjust the flow.

Alarm reset

In the event of an alarm initiated by the frequency inverter or the safety circuit, the compressor stops. The alarm is displayed on both Climatix and the Carel display.

In the event of an alarm, take corrective action to correct the fault, and then press the "Alarm reset" button on the Carel display for 3 seconds. If the safety circuit alarm trips repeatedly, an authorised refrigeration service company must be called in.





Air handling with focus on LCC

You are welcome to contact us

Switchboard:	+46 (0)47 075 88 00
Control system support:	+46 (0)47 075 89 00 styr@ivprodukt.se
Service:	+46 (0)47 075 89 99 service@ivprodukt.se
Spare parts:	+46 (0)47 075 86 00 reservdelar@ivprodukt.se
Visit us at:	www.ivprodukt.com
Documentation for your unit:	docs.ivprodukt.com
Technical documentation:	du@ivprodukt.se