

# EcoHeater home concept

A range of highly-efficient extract air handling units with integrated heat pumps for use in apartment buildings



*Air handling with focus on LCC*

# We have been conserving the Earth's **resources** for more than fifty years

Copenhagen Airport, Harpa Concert Hall in Reykjavik, sports arenas, schools, offices, hospitals, shopping centres and homes in a number of countries all have low energy consumption thanks to IV Produkt. IV Produkt has been involved in a long list of projects. With energy-efficient air handling units, we make it possible to recover energy, increase property value and conserve the Earth's resources.

IV Produkt is a privately-owned company based in Växjö in the Swedish county of Småland that develops and manufactures innovative solutions for air handling. We have been doing this since 1969.

Today, we are the market leader in the Nordics and have the fastest development rate in the industry. Quick turnaround times make us efficient, and the way in which we take responsibility makes it both safe and easy for you as a customer.

Energy efficiency and environmental concerns have been part of our business concept since 1991, prompting us to focus on the life cycle cost, LCC. In other words, the total cost of purchasing,



Development, production and head office in Växjö.

operation, service and environmental impact. We want this cost to be as low as possible and regard it as a natural aspect of our product development. We are ISO certified under 9001 and 14001, which we consider essential.

Our products and many years of experience enable us to identify innovative solutions for air handling which are perfect for your particular project. We will gladly help you personally to achieve our common goal of protecting the Earth's resources.

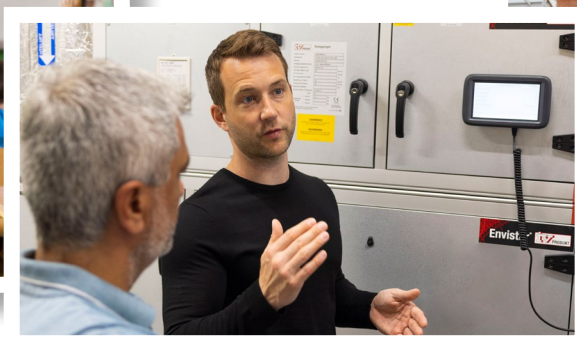

Eurovent Certification is a certification body which verifies the performance of air handling units in accordance with European and international standards. It allows products from different manufacturers to be compared on equal terms.

Our Envistar and Flexomix air handling units have been tested by Eurovent in accordance with EN 1886 and EN 13053. When performance calculations carry the above mark, you can be sure they have been certified by Eurovent Certification.

Europe is facing some major challenges. Many properties are in need of renovation and there is high demand for new-build properties. Existing property portfolios have to halve their energy consumption by 2050. We want to help improve the

energy efficiency of homes across Europe by means of innovative air handling solutions. This is why we have developed a customised Home Concept for blocks of flats, designed for both renovated and new-build properties.

# EcoHeater home concept

## Extract air handling units with integrated heat pumps

- Around 40% energy saving compared to extract air systems without energy recovery
- Energy savings comparable to what would be achieved if you convert to an FTX system
- Easier and less expensive to install than supply air ducts
- Installation does not disturb tenants
- Simple for property owners
- Simple for installation contractors
- One supplier, one contact

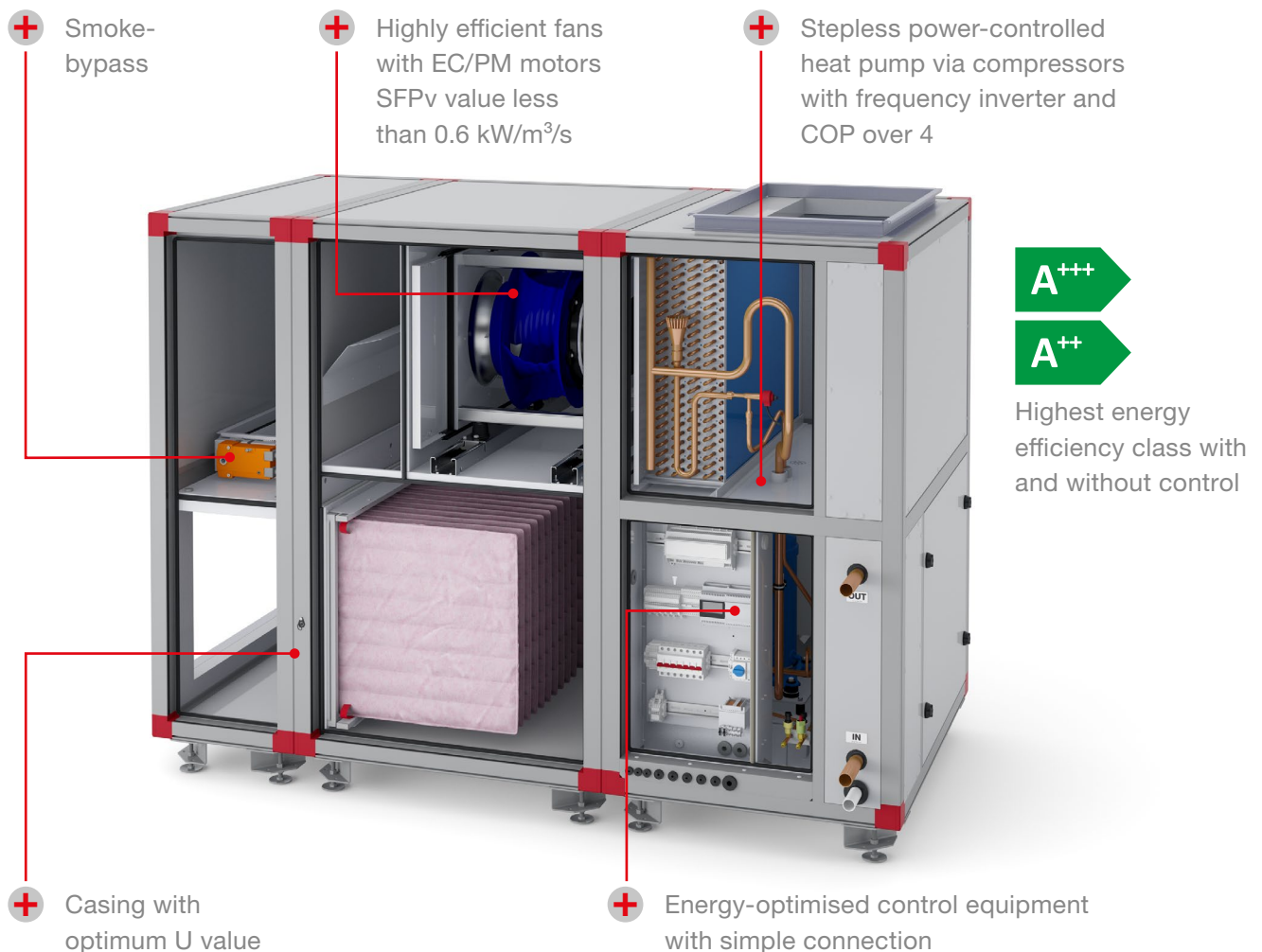

# Ventilation system

## Without energy recovery

Fresh air is brought in via trickle vents in window frames. Extract air is extracted through valves in bathrooms and kitchens. The heat in this system is not recovered, it disappears straight out via an extract air fan.

### Advantages

- Simple duct system

### Disadvantages

- No energy recovery means a lot of energy is wasted
- Does not meet Swedish National Board of Housing, Building and Planning requirements concerning refurbishment and new-builds

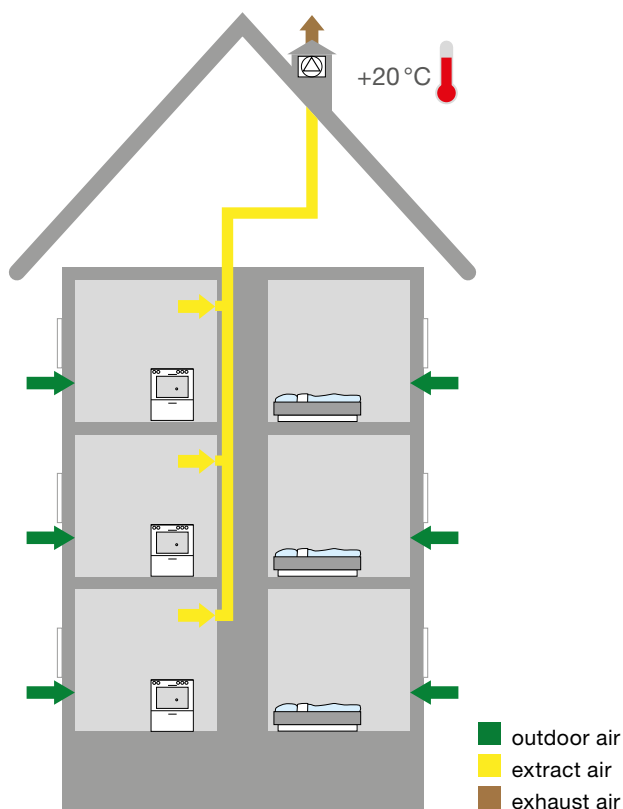

## Recovery via external heat pump

Fresh air is brought in via trickle vents in window frames. Extract air is extracted through valves in bathrooms and kitchens. The heat in this system is recovered through an external heat pump, which is connected to the extract air unit via a brine system.

### Advantages

- Simple duct system
- Heat recovery from the extract air

### Disadvantages

- Two heat exchangers, from air to brine and from brine to heat pump, which means that the efficiency is worse than in the case of a heat exchange.
- Brine systems that use cold liquid give rise to exhaust venting and corrosion problems, and must be insulated to prevent condensation
- Several different control systems have to be coordinated

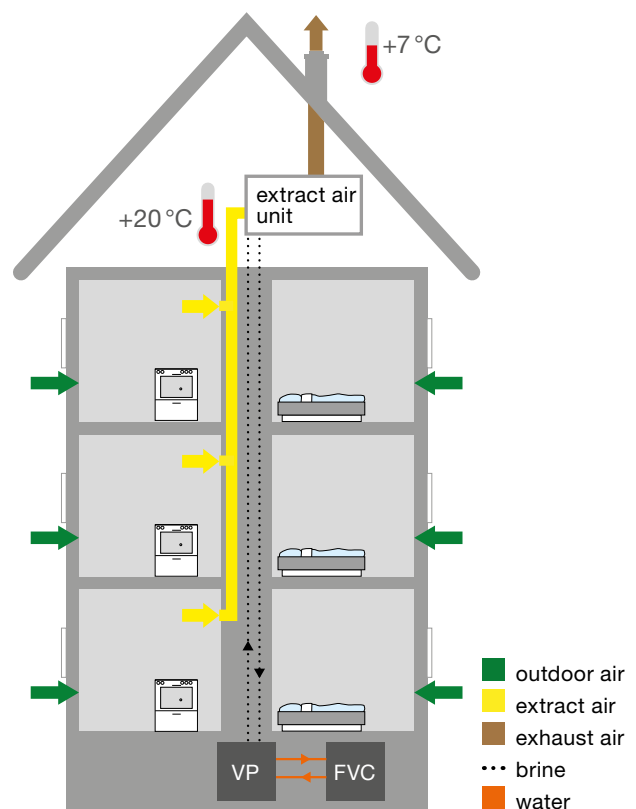

## Energy recovery and heat pump in one unit

EcoHeater recovers the heat in the extract air to heat water. The hot water can then heat the radiator system, and it can also be used for domestic hot water if necessary. The energy saving is comparable with that obtained from converting to an FTX system, and is significantly greater than with an external heat pump.

### Advantages

- Integrated, stepless and high-efficiency heat pump
- Prefabrication of the construction process
- Very simple installation without disturbing tenants
- One supplier, one contact



EcoHeater ensures simple installation with a COP over 4, resulting in enormous energy savings.

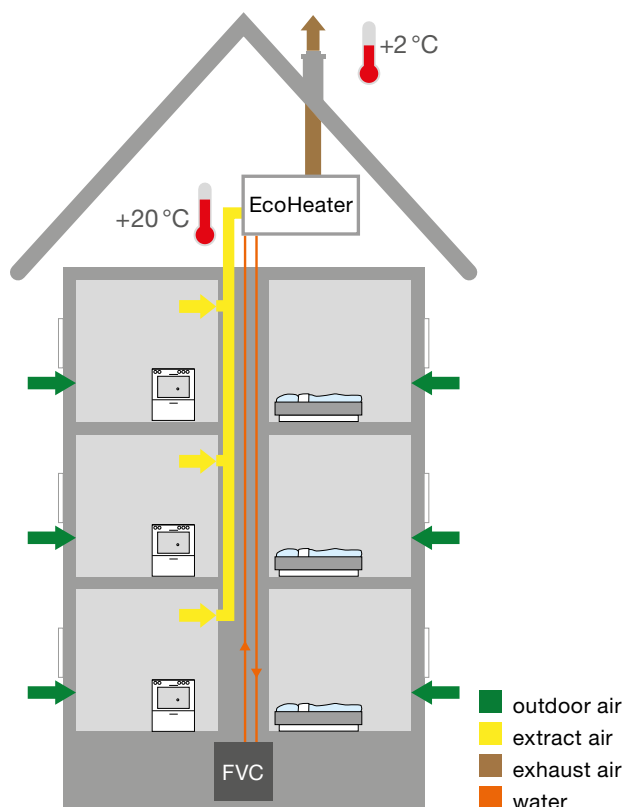

# Two in one

Property owners wanting to recover energy from extract air have traditionally been advised to purchase a heat pump and extract air unit separately from different suppliers. With EcoHeater, we have

created a prefabricated and highly efficient extract air unit with integrated heat pump. What you get is a complete unit from one supplier, with control equipment custom-designed for apartment buildings.

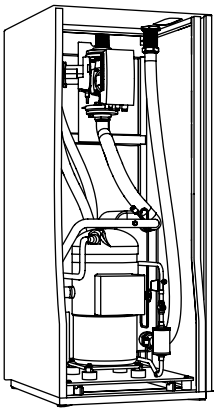

Heat pump

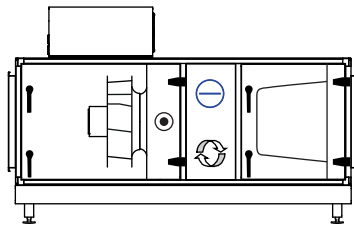

Extract unit



**EcoHeater**



## Unique versatility

The compressor is speed controlled via a frequency inverter, which means that EcoHeater is constantly adjusting in relation to the amount of energy that is available to recover from the extract air.

When tenants cook or take a shower, EcoHeater also recovers the extra energy that arises as a result of a higher moisture content and increased air flow.

This is unique to EcoHeater!

# Integration saves **energy**

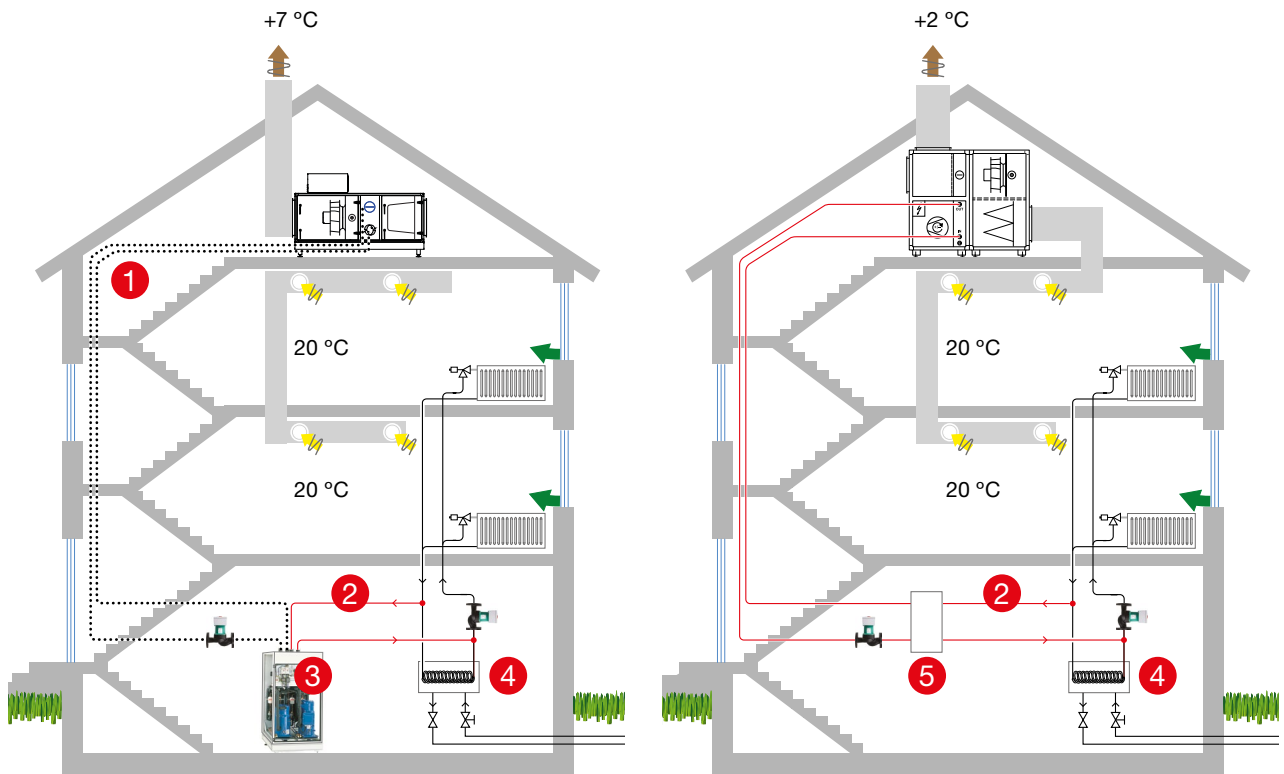

- 1 Brine solution
- 2 Hot water
- 3 Heat pump
- 4 District heating centre
- 5 4-way tank

## Energy recovery via external heat pump

- Two heat exchangers, extract air-to-brine and brine-to-heat pump. Results in **inferior efficiency**
- Requires **two circulation pumps**
- Brine systems that use cold liquid **result in exhaust venting and corrosion problems**, and must be insulated to prevent condensation
- Exhaust air temperature of approx. 7°C common
- **Several different control systems**

## Simpler and more efficient with EcoHeater

- Only one heat exchanger, extract air-to-heat pump. Results in **better efficiency**
- Only **one circulation pump**
- Only hot water between the EcoHeater and the central district heating facility, greatly **simplifies installation** compared with a brine solution
- Exhaust air temperature of approx. 2°C, i.e. 5 degrees more heat recovery
- **One control system**

# Bears comparison

Here we have performed energy calculations for a model building using identical assumptions in order to compare different solutions for ventilation and heat recovery. Depending on the annual mean temperature and the type of building and climate shell, EcoHeater can offer energy recovery comparable with an FTX system.

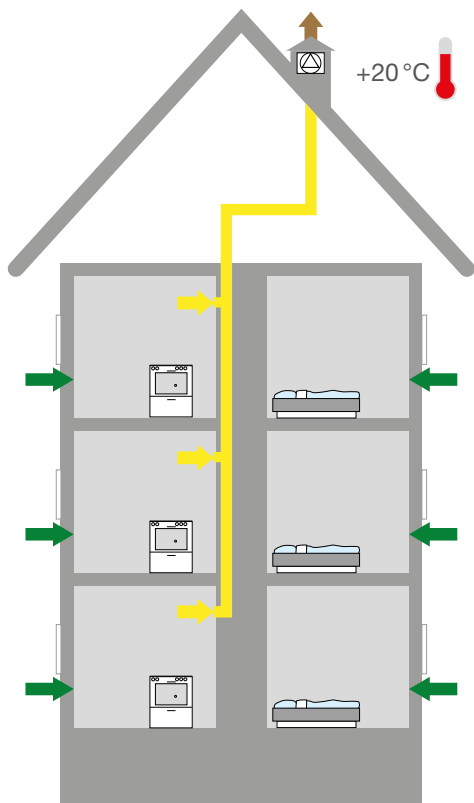

**Extract air system  
without heat recovery**

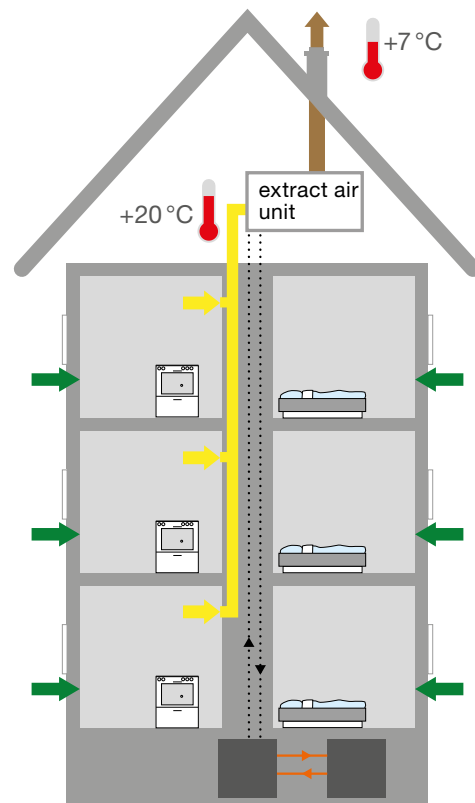

**Extract air system  
with heat recovery  
via external heat pump**

Running costs	40,400 €/year
Energy use	150 kWh/m <sup>2</sup> /year
Heating requirement	367,500 kWh
Recovered energy	0 kWh
Net saving <sup>2</sup>	0 kWh
Energy saving	0 kWh/m <sup>2</sup> /year
Energy saving	0 %
Cost saving	0 €/year
Cost saving	0 %

Running costs	31,900 €/year
Energy use	113 kWh/m <sup>2</sup> /year
Heating requirement	367,500 kWh
Recovered energy <sup>1</sup>	121,773 kWh
Net saving <sup>2</sup>	89,586 kWh
Energy saving	37 kWh/m <sup>2</sup> /year
Energy saving	24 %
Cost saving	8,600 €/year
Cost saving	21 %

**Criteria<sup>3</sup> for a model building 150 kWh/m<sup>2</sup>/year**

Air flow:	1.0 m <sup>3</sup> /s
Forced air flow:	1.3 m <sup>3</sup> /s
Annual mean temperature:	+6 °C
Return air temperature:	+20 °C
Surface area:	2,450 m <sup>2</sup>
Energy price for heating:	Cents 11/kWh
Energy price for electricity:	Cents 15/kWh

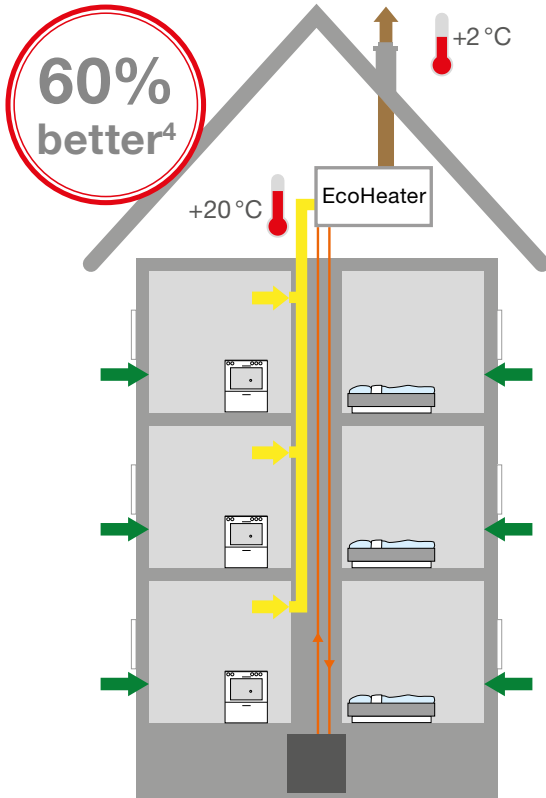

**EcoHeater**

Extract air unit with integrated heat pump

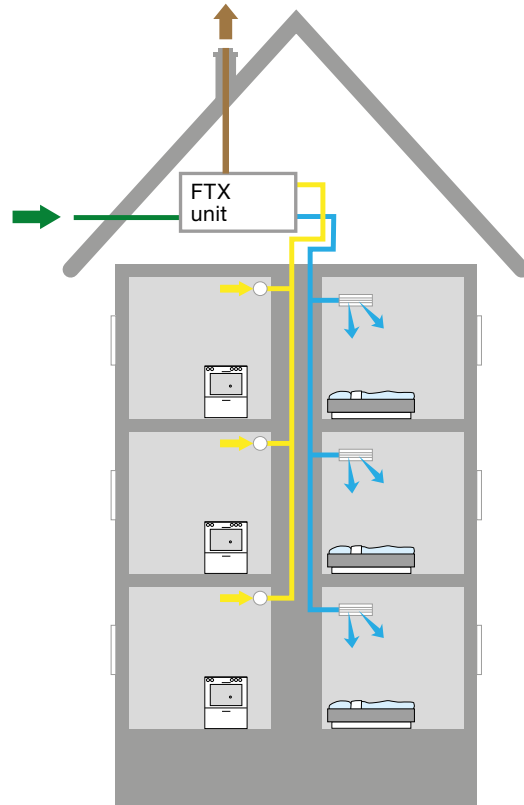

**Envistar<sup>®</sup>**

FTX system, extract/supply air unit with heat recovery

Running costs	26,100 €/year
Energy use	90 kWh/m <sup>2</sup> /year
Heating requirement	367,500 kWh
Recovered energy	192,486 kWh
Net saving <sup>2</sup>	146,656 kWh
Energy saving	60 kWh/m <sup>2</sup> /year
Energy saving	40 %
Cost saving	14,300 €/year
Cost saving	35 %

Running costs	28,200 €/year
Energy use	103 kWh/m <sup>2</sup> /year
Heating requirement	367,500 kWh
Recovered energy <sup>5</sup>	122,094 kWh
Net saving	114,385 kWh
Energy saving	47 kWh/m <sup>2</sup> /year
Energy saving	31 %
Cost saving	12,300 €/year
Cost saving	30 %

1 Brine system with an exhaust air temperature of +7 °C.  
 2 Recovered energy minus electricity consumption by compressors, pumps, etc.  
 3 Excl. hot water and energy to extract air fans.  
 4 With an external heat pump, operating costs are reduced by € 8,600/year and energy usage is reduced by 37 kWh/m<sup>2</sup>/year. EcoHeater reduces operating costs by € 14,300/year, and energy usage is reduced by 60 kWh/m<sup>2</sup>/year, which is approx. 60% better than with an external heat pump.  
 5 SFPv 1.5 kW/m<sup>3</sup>/s, dry temperature efficiency 82%.

# Top performance

## Stepless power-controlled heat pump

- Adaptive, adjustable heat recovery
- Speed controlled scroll compressors with PM motors
- Electronic expansion valve
- Flow sensor for the water circuit, safeguards monitoring and operation
- Optimised control equipment
- Output water temperature 25 to 60 °C

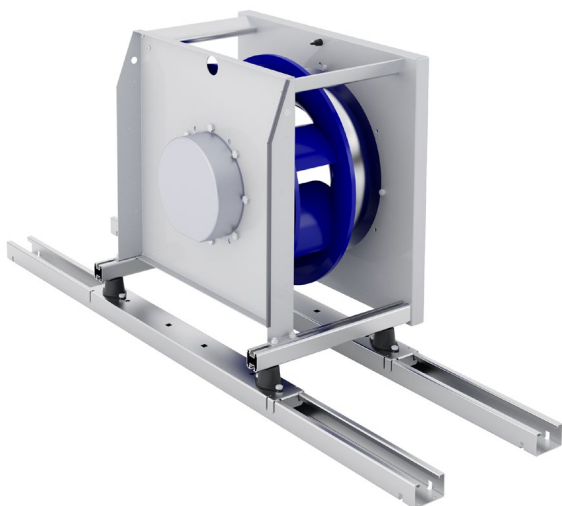

## Energy-efficient fans with PM motors and EC control

- Direct-driven and speed-controlled fans
- Very high efficiency
- Fan and motor mutually balanced
- The fan is mounted on rails, making it easy to pull out for easy servicing
- Optimised for minimal power usage, i.e. the lowest SFPv value possible

## Filter

- Deep-folded bag filter
- Filter type with low pressure drops
- Long service life – few replacements
- Industry standard filter sizes wherever possible

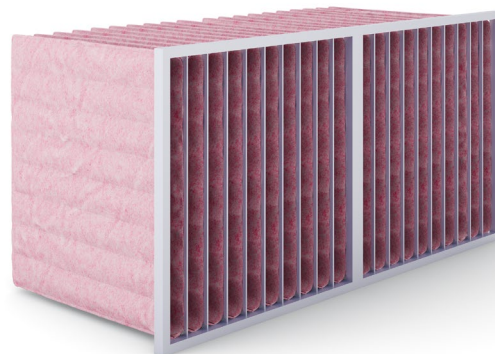



# Customised module dimensions to **facilitate** transport

When we develop AHUs, a lot of effort is invested in making it easy to transport the units into the property. Thanks to our extensive experience, we have developed many smart solutions that make it easy and cost-effective to position the air handling units in the installation site,

without impacting on the building. All modules can be transported through a standard door with a width of 900 mm.

We hope this will make it easier for you to get the unit into the building, and even into narrow lifts.

# Keeping track of your kilowatt hours!

We are now offering an optional extra for our air handling units in the Envistar range in the form of the in-house developed software Energy Watch which helps you to keep track of your kilowatt hours.

Energy Watch is a unique function for monitoring and optimising the energy use in the air handling unit.

You can easily see the meter values and information in the app, the hand-held terminal or in BMS system.



Energy watch measures and shows:

## Heat recovery

- Recovered energy and power
- Heat pump efficiency – COP
- Energy use of compressor

## Fans

- Energy input and power
- Specific fan power, SFP
- Density correction of the air flow with measurement at four points for the best possible accuracy

# Take control using our IV Produkt AHU Controls app

You can control our unit using the IV Produkt AHU Controls app. You connect the unit to the internal network in the property, if the building has Wi-Fi. If you cannot connect the unit to the internal network, we offer an optional Wi-Fi router for the unit.

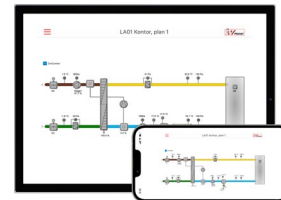

- Control your unit easily via smartphone or tablet
- Start up the unit and adjust the values
- React quickly in the event of an alarm
- See event logging and history
- Clear interface and summary flow chart



The app is available to download free of charge for iOS och Android™. You can adjust setpoints and settings, see any alarms and much more without needing to be in the plant room.

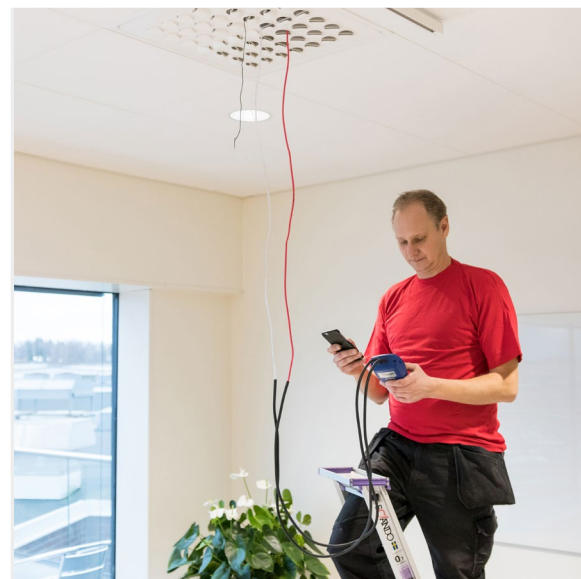

# Gives you **full control** – wherever you are



## IV Produkt Cloud service

IV Produkt Cloud is a cloud service for our air handling units with integrated control, in which you and your colleagues will be able to keep track of your systems no matter where you are. The cloud service is always accessible wherever there is internet access. In other cases, there is an optional 4G router.

IV Produkt Cloud is available as a free subscription called Free, and a paid subscription called Service+. The administrative service Digital Wallet helps you manage your subscriptions.

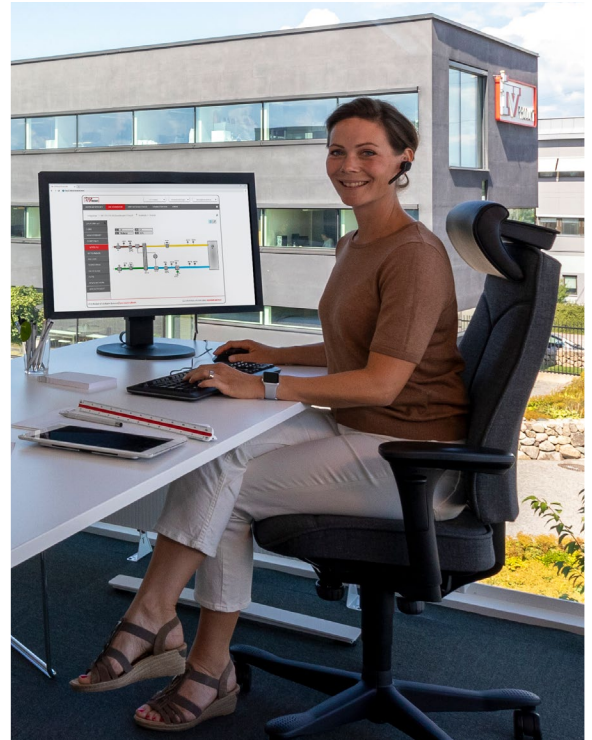

- Completely free subscription
- See status and flow chart and reset alarms
- Service+ included the first month



- Full access to change control functions and adjust values
- Alarm notifications, history and upgrades
- Good for balancing and commissioning
- Remote support capability from us at IV Produkt

## Lower your costs with Digital Wallet

For you who have multiple air handling units and wish to manage your own account. Switch between Free and Service+ subscriptions as the requirements of the system change.



# Fire functions

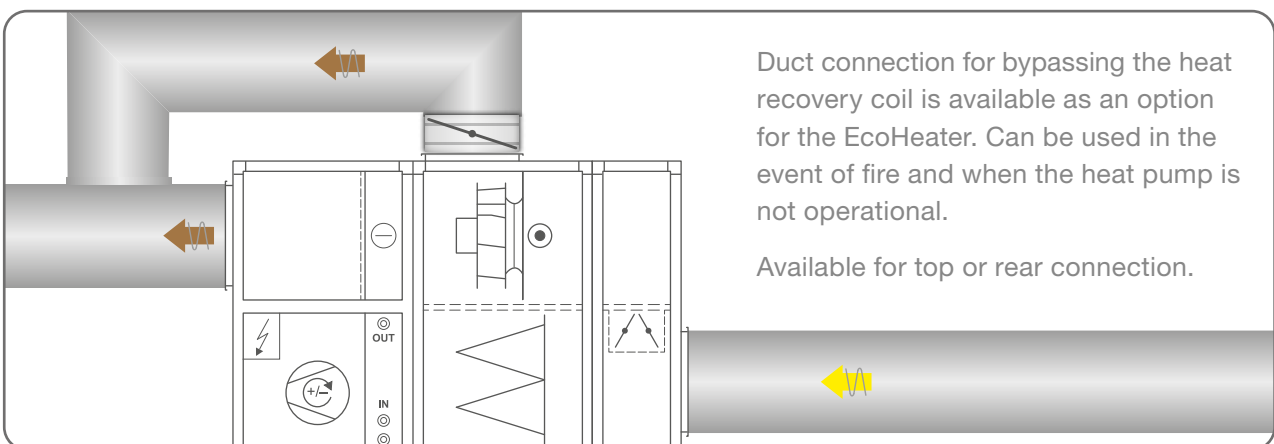
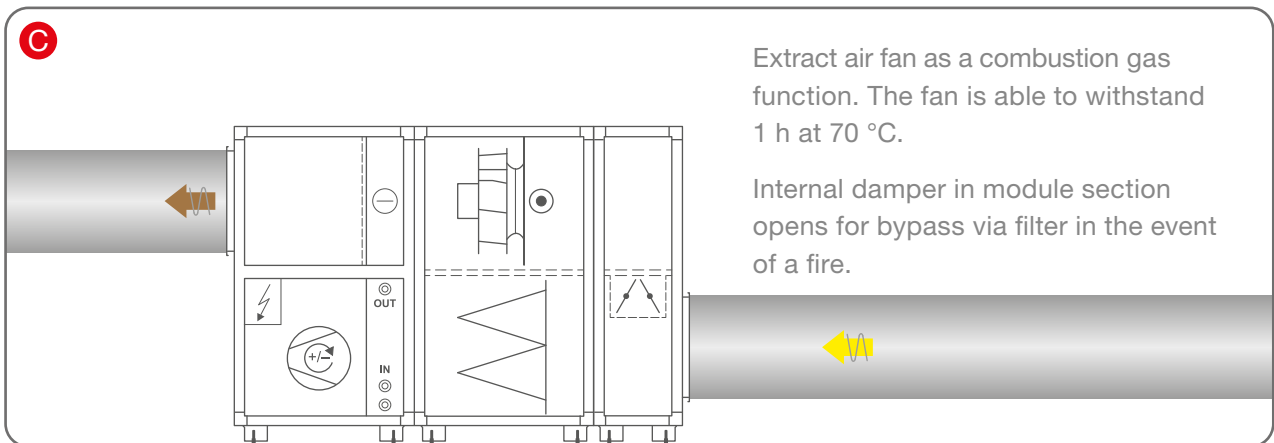
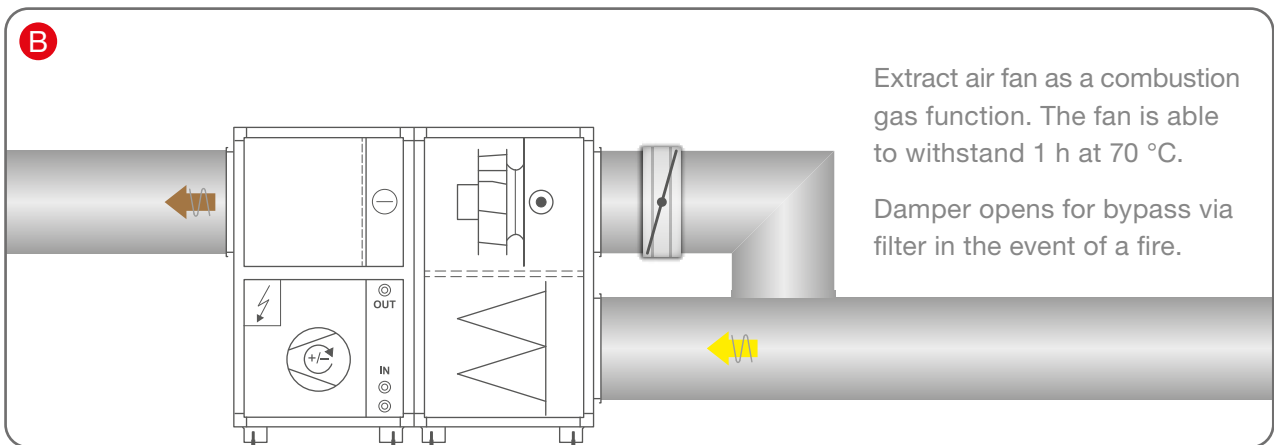
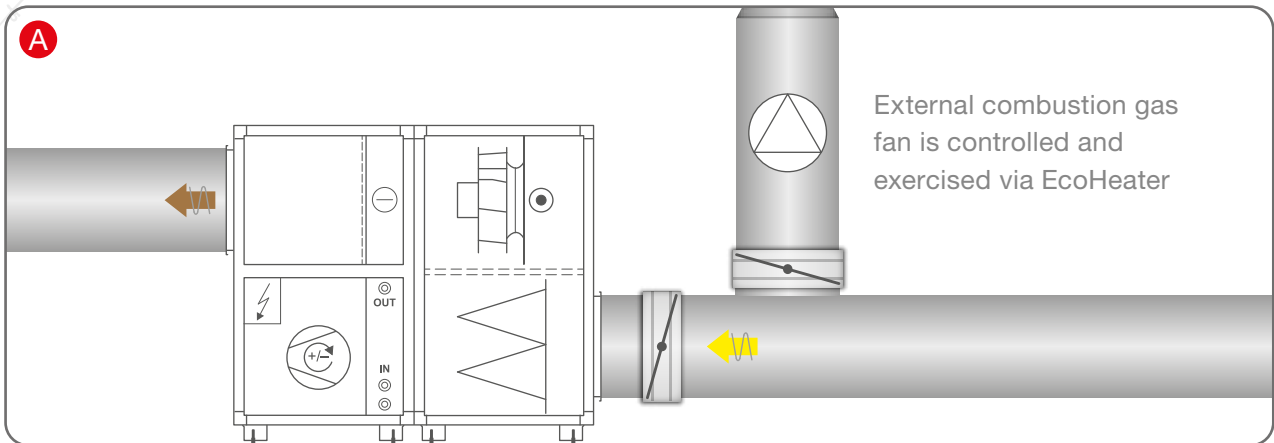



## Energy saving all year round

The EcoHeater is available for both indoor and outdoor use. The units are supplied complete and ready for commissioning.

The outdoor version of the EcoHeater has a factory-fitted roof with a drop towards the reverse side and a soundproofed exhaust air hood.



## Flexible hoses supplied as standard

The EcoHeater comes with steel-spun, diffusion-tight connecting hoses to prevent butt-jointed pipe installation.

# Reduced heating costs

Brf Spetsamossen is a housing association with 76 apartments located centrally in Växjö.

**The association's vision:** "The association strives for continued good finances, well-maintained buildings and plantings. Brf Spetsamossen wants to be a housing association characterized by innovative and sustainable housing, security, openness and joint efforts for the future for all members and residents."

In order to make the properties more energy efficient, EcoHeater size 150 was installed in one of three building blocks. The ventilation units are monitored by IV Produkt's cloud service IV Produkt Cloud.

Thanks to the EcoHeater installation, energy consumption was reduced by 40 kWh/m<sup>2</sup>/year.

<b>Property owner:</b>	BRF Spetsamossen (HSB)
<b>Year of construction:</b>	1996
<b>Number of apartments:</b>	A total of 76 apartments spread across 3 buildings. 2 premises.
<b>A-temp:</b>	Appartments 4 518 m <sup>2</sup> and premises 82 m <sup>2</sup>
<b>Air flow:</b>	Approx. 850l/s
<b>Annual COP:</b>	5,0
<b>Energy before:</b>	129 kWh/m <sup>2</sup>
<b>Energy after:</b>	89 kWh/m <sup>2</sup>
<b>Purchased district heating:</b>	
<b>Before:</b>	2021, 583 855 kWh
<b>After:</b>	2023, 403 487 kWh

- Reduced heating costs by approximately € 12,450/year.
- The savings could have been even greater if an EcoHeater had been installed in each house.



# Energy efficiency in two steps



Nybro Bostads AB wanted to make Drabanten 1 & 2 more energy efficient, the first in 2019 and the second in 2020.

In Drabanten 2, which consisted of two properties, they went from one substation to one substation in each house with traditional series connection with domestic hot water charging. In Drabanten 1, which consists of three properties, they went from one substation to one substation in each house. Here they have installed new substations that are hybrid substations that make both radiator water and domestic hot water and keep the return temperature down as much as possible.

Thanks to the EcoHeater installation, energy consumption was reduced by 58 kWh/m<sup>2</sup>/year.

## Drabanten 2 (two buildings)

<b>Property owner:</b>	NBAB
<b>Year of construction:</b>	the 1960s
<b>Number of apartments:</b>	35 x 2
<b>A-temp:</b>	2915 m <sup>2</sup> x 2
<b>Air flow:</b>	1,10 m <sup>3</sup> /s x 2
<b>Annual COP:</b>	4,0
<b>Energy before:</b>	162 kWh/m <sup>2</sup> /year
<b>Energy after:</b>	104 kWh/m <sup>2</sup> /year
<b>Energy savings:</b>	58 kWh/m <sup>2</sup> /year
<b>Purchased district heating before and after for two buildings:</b>	
<b>Energy before:</b>	657 MWh
<b>Energy after:</b>	165 MWh

- Reduced heating costs by approximately € 19,150/year.
- Energy savings 58 kWh/m<sup>2</sup> per year.

# Savings in reality



## Stockholmshem

A tower block with 28 apartments in the district of Västertorp, south of the City of Stockholm, is owned and managed by Stockholmshem. An EcoHeater was installed in the building with a view to reducing heating costs.

The EcoHeater was connected to the heating system, and in September the entire heat output from energy recovery is used to meet the needs of the heating system.

The cost of district heating could be halved thanks to the EcoHeater installation.

<b>Property owner:</b>	Stockholmshem
<b>Year of construction:</b>	1949
<b>Number of apartments:</b>	28
<b>A-temp:</b>	2,035 m <sup>2</sup>
<b>Air flow:</b>	1,100 l/s
<b>Annual COP:</b>	approx. 3.6
<b>Energy before:</b>	192 kWh/m <sup>2</sup>
<b>Energy after:</b>	104 kWh/m <sup>2</sup>

- Heating costs reduced by approx. € 14,360/year
- The installation used the previous generation of EcoHeater. The new EcoHeater is 10–15% more energy-efficient than its predecessor.

## Rikshem, Helsingborg

There is a property in the district of Planteringen in Helsingborg which comprises 24 rental apartments over 4 storeys.

Rikshem wanted to reduce the energy consumption of its property portfolio, and had EcoHeater installed in the attic. The property previously had extract air ventilation.

A significant reduction in energy consumption for district heating was seen after just one year.

<b>Property owner:</b>	Rikshem
<b>Year of construction:</b>	1985
<b>Number of apartments:</b>	24
<b>A-temp:</b>	1,546 m <sup>2</sup>
<b>Air flow:</b>	750 l/s
<b>Annual COP:</b>	approx. 4.5
<b>Energy before:</b>	120 kWh/m <sup>2</sup>
<b>Energy after:</b>	70 kWh/m <sup>2</sup>

- Savings of 50 kWh/m<sup>2</sup> and an ROI time of 4.7 years
- The installation used the previous generation of EcoHeater. The new EcoHeater is 10–15% more energy-efficient than its predecessor.

# Fast installation



The Skvallertorget housing association in central Kalmar wanted to improve energy efficiency at the property and initially considered converting to an FTX system. Its apartments were previously supplied with extract air ventilation only.

The association decided to use EcoHeaters for the property as they could be installed without disturbing tenants and yet the solution they offer is energy-efficient.

The EcoHeater was lifted down through the hole in the roof that was made for the previous extract air fan, and a storage room in the attic could be used as a fan area.

“ We mainly chose EcoHeater because of the short design time and the fact that there was no need for the installation work to disturb our tenants. ”

Martin Lundin, Riksbyggen Kalmar

<b>Property owner:</b>	Riksbyggen
<b>Year of construction:</b>	1960
<b>Number of apartments:</b>	27
<b>A-temp:</b>	3,300 m <sup>2</sup>
<b>Energy before:</b>	150 kWh/m <sup>2</sup>
<b>Energy after:</b>	82 kWh/m <sup>2</sup>
<b>ROI time:</b>	4.9 years

- Short design period
- Installation did not disturb tenants
- The installation used the previous generation of EcoHeater.  
The new EcoHeater is 10–15% more energy-efficient than its predecessor.

# The most profitable sustainability investment

It is easy to make investment decisions with calculations from IV Produkt Designer. The calculation includes accounting of

- Energy savings
- Economy och payback-period
- Calculation of increased property value

An older ventilation unit that appears to be in good condition may be unexpectedly profitable to replace. It is easy to calculate energy savings and payback period when replacing e.g. a unit from the 1990s. Given that it is over 20 years old, today's units are significantly more efficient.

On this page and the next you can see an example of a completed apartment building project with replacement of older ventilation units.

## ENERGY



**EcoHeater** Investment calculation EHP

**Project name** Apartment Building  
**Name of AHU** Ecoheater  
**Size** 190-2 3,600 m³/h

### Energy

#### Temperatures

	New	Existing
Return air temperature	21.0	21.0 °C
Average annual temp	6.0	6.0 °C
Exhaust air temperature	2.0	21.0 °C

#### Running data

	New	Existing
Basic flow	3,600	3,600 m³/h
Annual heating factor	4.3	0
SFP value	0.47	0.60 kW/(m³/s)

#### Annual energy usage

	New	Existing
Additional heating for warming-up	136,317	319,650 kWh
Electricity consumption	46,870	5,256 kWh
Specific energy consumption heating and ventilation	71	126 kWh/m²

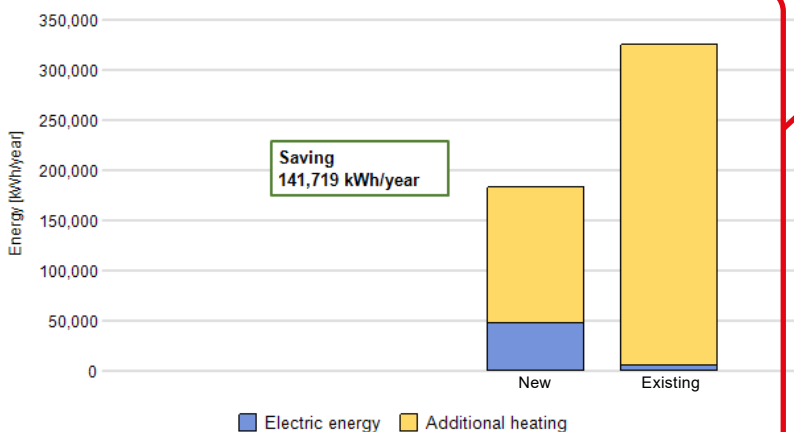

Saving	55	kWh/m²
Saving %	44	%/m²

- Savings: **141,700** kWh/year
- Equivalent to **55** kWh/m²/year
- Means savings of 44%
- Can be used in the sustainability report.

# ECONOMY

- Payback period: **4.3** years
- Energy cost savings year 1: approx. **13,900€**
- Savings over 20 years: approx. **285,900€**
- The increase in property value is four times the investment cost.

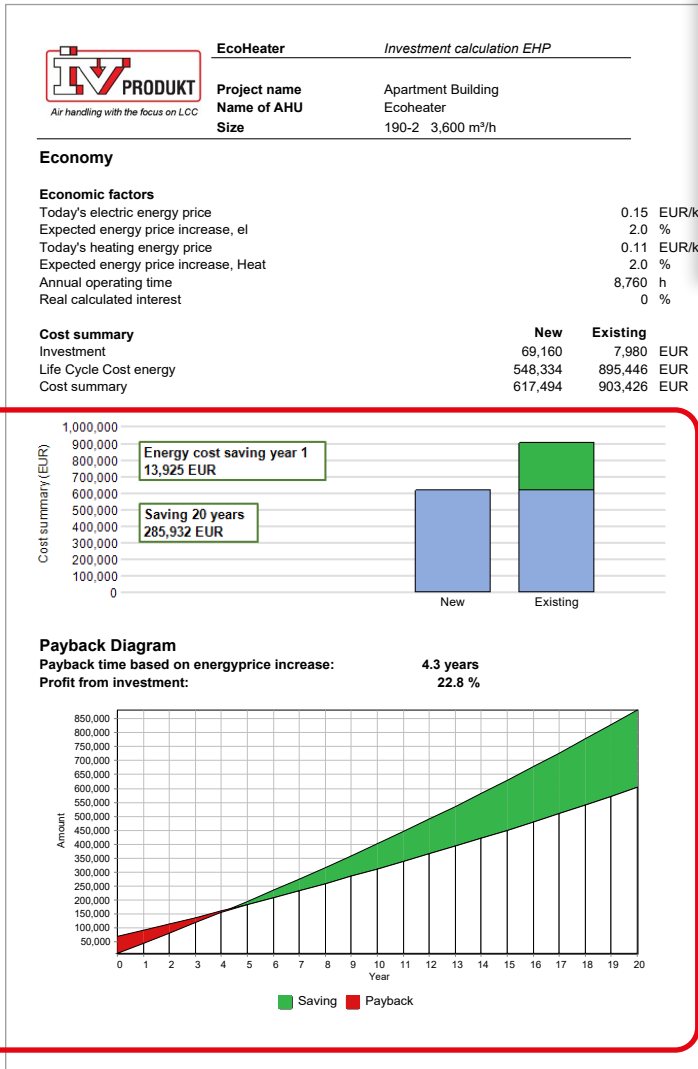

# PROPERTY VALUE

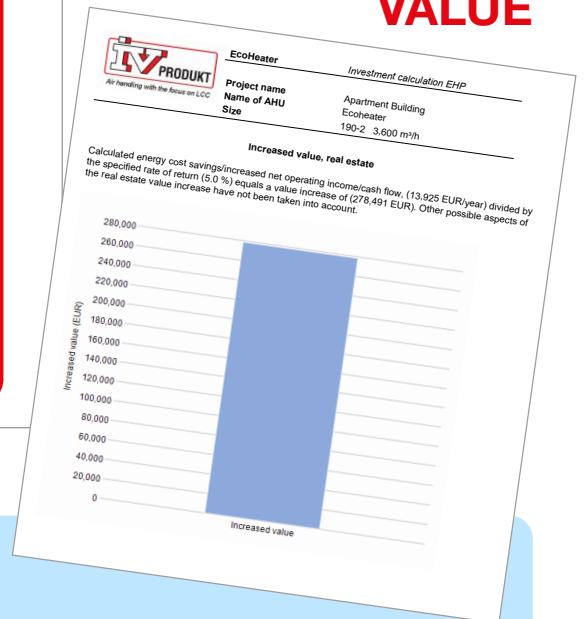

## Increase in property value

Energy savings reduce the property's total operating costs. The net operating income is calculated by deducting operating costs from total rental income. If you divide the net operating income by the property's required rate of return, you get the property value.

A higher net operating income thus leads to an increase in property value. And a higher property value creates opportunities for making new investments.



net operating profit

required rate of return %

13,900€

5 %

=

property value

=

278,000€



# EcoHeater home concept

## Configurations

Right- or left-handed versions can be chosen during the project planning process in accordance with the example below. Please note that the pipe connections are placed differently on the left- and right-handed versions.

 Extract air  Exhaust air

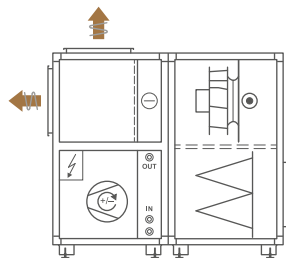

Left-handed indoor version

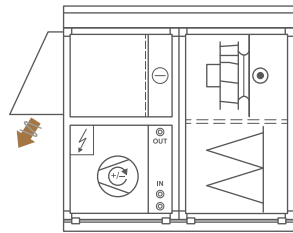

Left-handed outdoor version

Duct damper  
EMT-01



115

Duct attenuator  
EMT-02

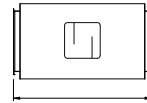

500-1000

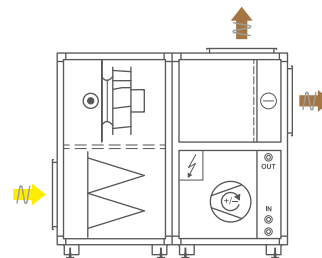

Right-handed indoor version

## Energy efficiency class

Highest energy efficiency class with and without control. See [ivprodukt.com](http://ivprodukt.com) for more information.

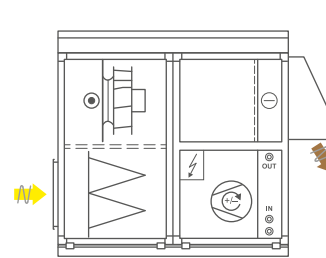

Right-handed outdoor version

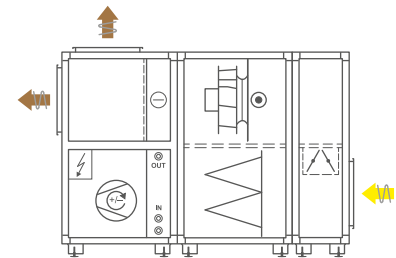

Left-handed indoor version with combustion gas bypass

EcoHeater is supplied in two sections. The sections have a max. length of 890 mm.

Size	Cross-section dimensions (mm)		Length (mm)			Air flows (m <sup>3</sup> /s)			Nominal <sup>c</sup> heating power (kW)	Refrigerant volume (kg)	Max. electrical power input <sup>d</sup> (kW)	External <sup>e</sup> fuse protection (AT)	Weight (kg)		
	Width	Height <sup>a</sup>	Duct connection	Complete unit	Fan section	Heat pump section	Combustion gas bypass section	Min.						SFP <sub>v</sub> 0.6 <sup>b</sup>	Max.
060	890	1,230	500 × 300	1,530	740	790	442	0.15	0.40	0.50	14.6	1.6	6.1	16	278
100	1,020	1,295	700 × 300	1,530	740	790	442	0.24	0.58	0.93	19.3	2.2	7.6	20	331
150	1,120	1,485	800 × 500	1,680	890	790	442	0.40	1.17	1.44	25.2	2.7	9.8	16/20	508
190	1,400	1,485	1,000 × 500	1,780	890	890	442	0.71	1.44	2.12	45.0	4.6	18.9	32	587
240	1,400	1,686	1,000 × 600	1,780	890	890	442	0.78	1.63	2.49	49.2	6.3	19.4	32	671
300	1,616	1,686	1,200 × 600	1,780	890	890	442	1.05	1.88	3.00	65.2	7.2	24.8	40	778

a – Stand increases the height by 100 mm.

b – Applies to units with a damper, M5 filter and duct pressure 200 Pa (sizes 100–300), 150 Pa (size 060).

c – With extract air at 20 °C, 35% relative humidity, heat transfer medium 40 °C, exhaust air temp. 2 °C and max. compressor frequency.

d – Concerns max. supplied electrical power (fan section + heat pump) at max. air flow and compressor frequency.

e – 3 × 400 V+N frequency inverter operation. Fuses in sizes 100–300 depending on the fan variant.

See IV Produkt Designer for the relevant value.

For object-specific data, see the product selection program IV Produkt Designer

## Flow ranges for the various sizes

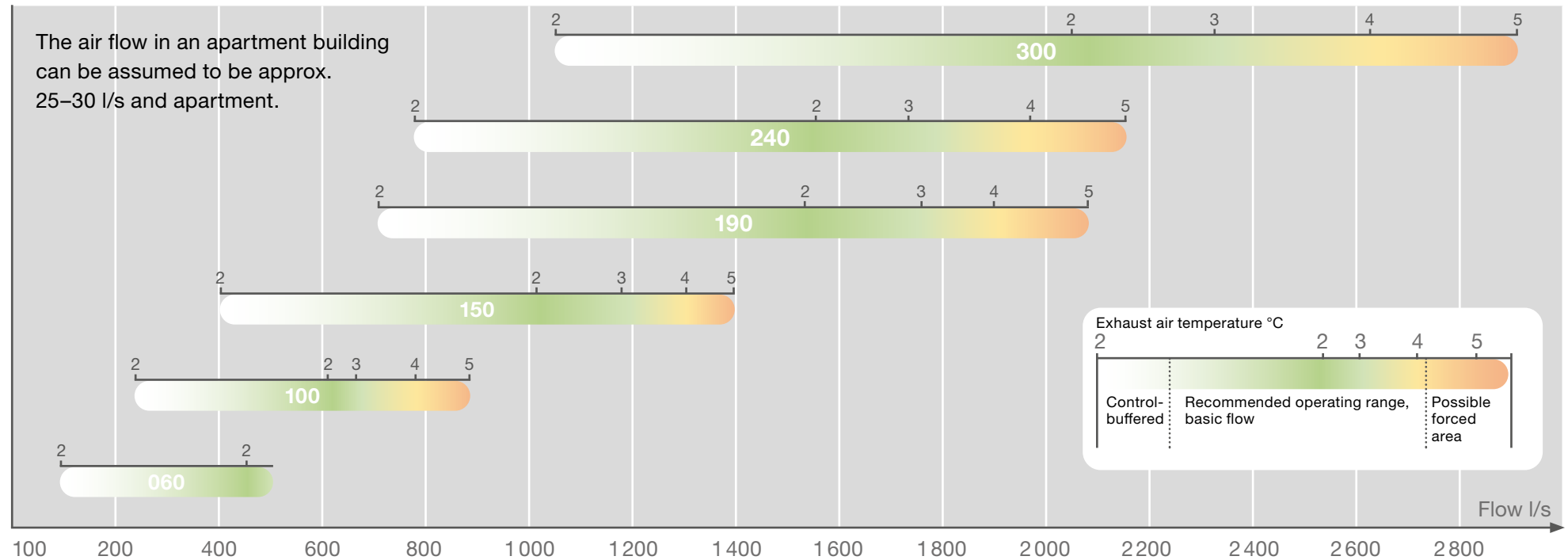

Extract air temperature +21 °C and an average RH of 30% over the year. The relative humidity (RH) of the extract air varies depending on the outdoor temperature and may, for example, be 40% at +10 °C and 20% at -20 °C.

## Coefficient of performance (COP)

The coefficient of performance depends on the operating case concerned, e.g. air temperature, flow, moisture content and heat transfer medium temperature. It also depends on how well the capacity of the heat pump matches the requirements of the property. The seasonal performance factor is crucial when comparing different extract air heat pumps. It shows how efficient the heat pump is throughout a full year, and is a more representative indication than the coefficient of performance in a particular operating case. The higher the number, the more efficient the heat pump. EcoHeater has a seasonal performance factor of 3.6–4.2, and can instantaneously achieve a coefficient of performance of up to 5.0.

The **IV Produkt Designer** product selection program will give you everything you need to select a unit for your project. Download it for free at [ivprodukt.com](http://ivprodukt.com) or contact us for assistance.

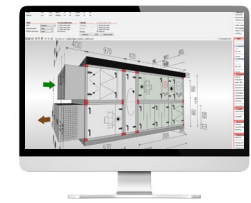

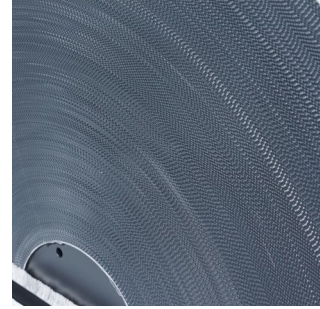
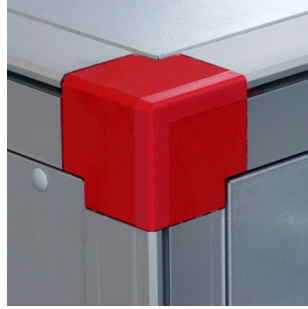
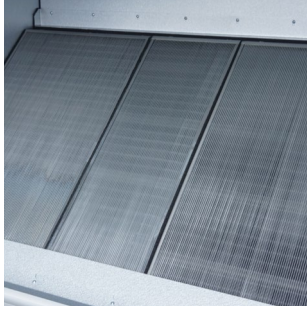
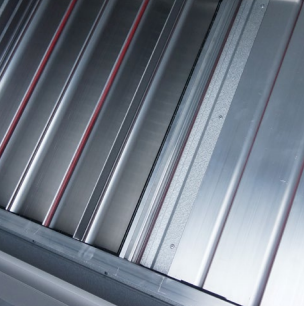
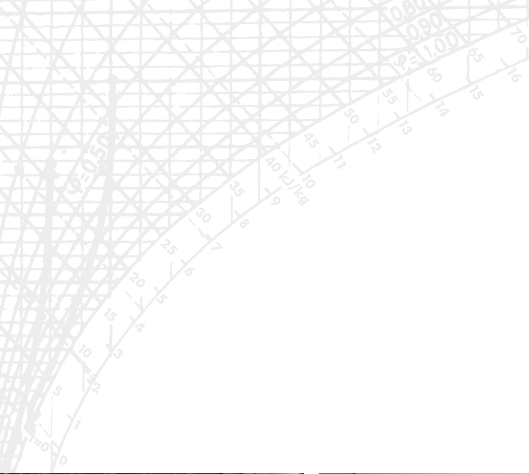

This is just part of our wide range. For our full range,  
see [www.ivprodukt.com](http://www.ivprodukt.com) or contact us to find out more.

## You are welcome to contact us

### Head office

Sjöddevägen 7  
SE-350 43 Växjö  
Switchboard: +46 470 75 88 00  
Control support: +46 470 75 89 00  
[info@ivprodukt.se](mailto:info@ivprodukt.se)  
[www.ivprodukt.se](http://www.ivprodukt.se)

### IV Produkt Ltd

Sweden House, 4th Floor,  
5 Upper Montagu Street,  
LONDON W1H 2AG  
Phone: 020 7258 5152



*Air handling with focus on LCC*