

# Envistar<sup>®</sup> home concept

A series of energy-efficient air handling units for blocks of flats with FTX systems



*Air handling with focus on LCC*

# We have been conserving the Earth's **resources** for more than fifty years

Copenhagen Airport, Harpa Concert Hall in Reykjavik, sports arenas, schools, offices, hospitals, shopping centres and homes in a number of countries all have low energy consumption thanks to IV Produkt. IV Produkt has been involved in a long list of projects. With energy-efficient air handling units, we make it possible to recover energy, increase property value and conserve the Earth's resources.

IV Produkt is a privately-owned company based in Växjö in the Swedish county of Småland that develops and manufactures innovative solutions for air handling. We have been doing this since 1969.

Today, we are the market leader and have the fastest development rate in the industry. Quick turnaround times make us efficient, and the way in which we take responsibility makes it both safe and easy for you as a customer.

Energy efficiency and environmental concerns have been part of our business concept since 1991, prompting us to focus on the life cycle cost, LCC. In other words, the total cost of purchasing,



Development, production and head office in Växjö.

operation, service and environmental impact. We want this cost to be as low as possible and regard it as a natural aspect of our product development. We are ISO certified under 9001 and 14001, which we consider essential.

Our products and many years of experience enable us to identify innovative solutions for air handling which are perfect for your particular project. We will gladly help you personally to achieve our common goal of protecting the Earth's resources.

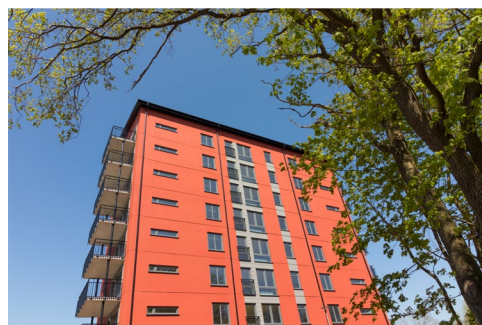

Eurovent Certification is a certification body which verifies the performance of air handling units in accordance with European and international standards. It allows products from different manufacturers to be compared on equal terms.

Our Envistar and Flexomix air handling units have been tested by Eurovent in accordance with EN 1886 and EN 13053. When performance calculations carry the above mark, you can be sure they have been certified by Eurovent Certification.

Europe is facing a major challenge. Many properties are in need of renovation and there is high demand for new-build properties.

The objective of the European Commission is to at least double the annual energy renovation rate of buildings by 2030 and to encourage more renovations.

This could result in 35 million renovated building units by 2030.

We want to contribute to improving the energy efficiency of homes across Europe through innovative air handling solutions. We have therefore developed a customised Home Concept for blocks of flats intended for both renovated and new-build properties.

# Envistar<sup>®</sup> home concept

## A series of centrally located high-efficiency air handling units

- Extremely low energy consumption
- Each unit can be used for 6–240 flats
- Can be controlled and monitored using the IV Produkt AHU Controls app or using the IV Produkt Cloud service
- Simple for property owners
- Simple for installation contractors
- Simple for tenants

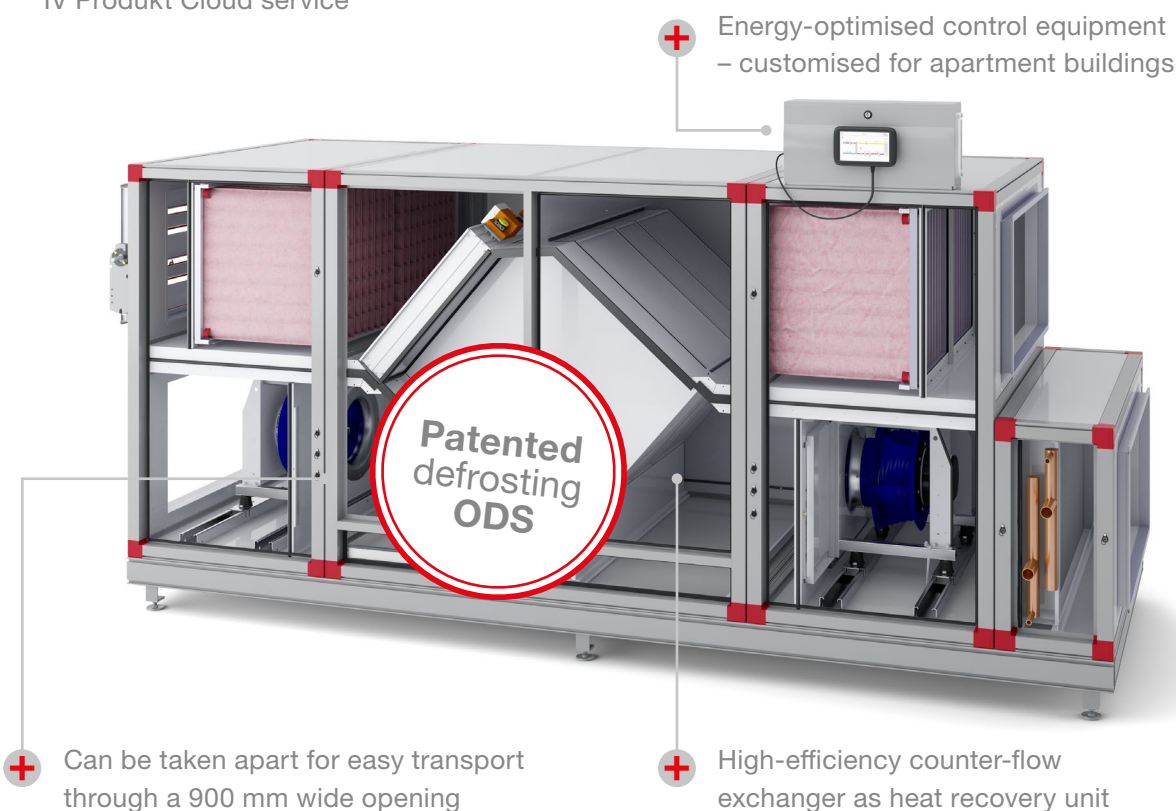

**The temperature efficiency** must be calculated using dry air. For example, 85 per cent dry temperature efficiency is equivalent to around 90 per cent humid temperature efficiency. Read more about this further on in the brochure.

# Residential ventilation today

## “F-system”, extract air system without heat recovery

Fresh air is brought in via trickle vents in window frames. Extract air is extracted from bathrooms and kitchens through valves. The heat in this system is not recovered; it is discharged directly into atmosphere via an extract air fan.

### Advantages

- Simple duct system

### Disadvantages

- No energy recovery means a lot of energy is wasted
- Complicated access for filter replacement and cleaning of trickle vents
- Cold and draughty
- Does not meet Swedish National Board of Housing, Building and Planning requirements concerning refurbishment and new-builds

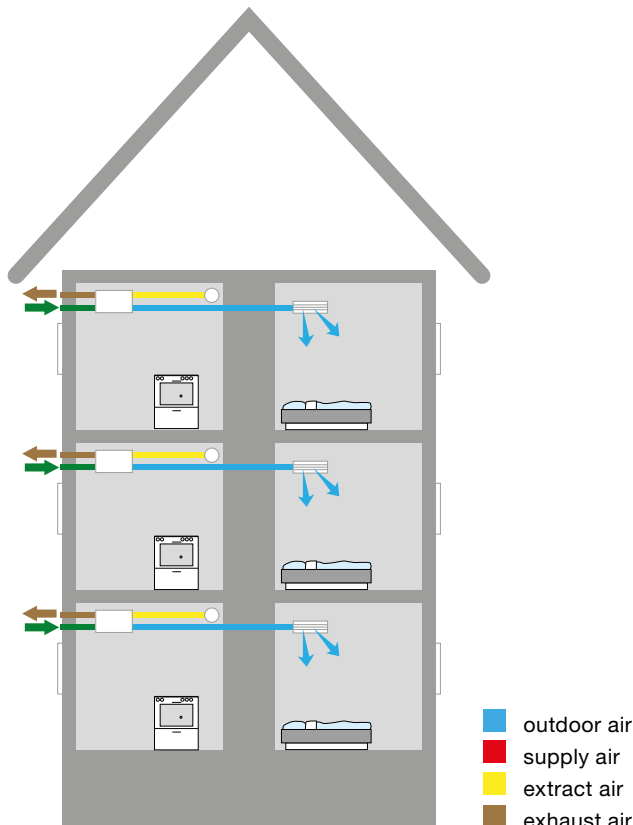
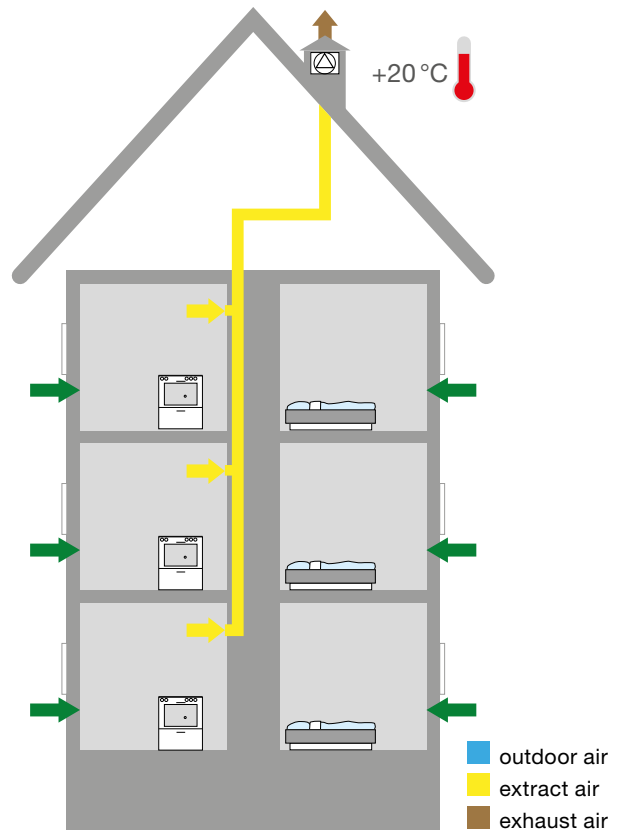

## Flat unit, FTX with heat recovery

### Advantages

- Heat recovery

### Disadvantages

- Many units have high maintenance costs. For example, 30 flats = 30 units, which means 60 fans and 60 filters
- Complicated access for filter replacement
- Risk of disruptive noise
- More expensive installation than central unit

# Residential ventilation today

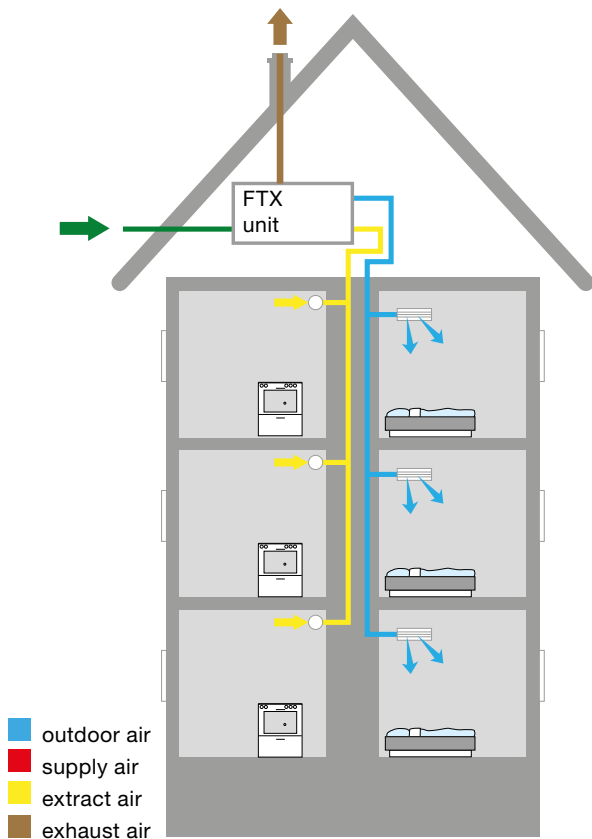

Older centrally located FTX unit with run-around coil, plate heat exchanger or heat pipe

## Advantages

- Easy access for filter replacement and servicing. For example, 30 flats = one unit, which means two fans and two filters
- Central control and monitoring
- Separate air flows, no risk of odour transfer between extract and supply air

## Disadvantages

- Fans with low efficiency, often belt-driven, and with high maintenance costs
- Low heat recovery, 40–55%

**FTX**

**F = extract air**

**T = supply air**

**X = heat recovery**



run-around coil



plate heat exchanger



heat pipe

# May we introduce our...

## Envistar<sup>®</sup> home concept

Envistar Home Concept is a series of centrally located, high-efficiency FTX units tailored specifically for blocks of flats.

Customised control equipment and a wide range of fans, motors and heat recovery units provide everything you need for energy-optimised air handling.

**FTX**  
F = extract air  
T = supply air  
X = heat recovery

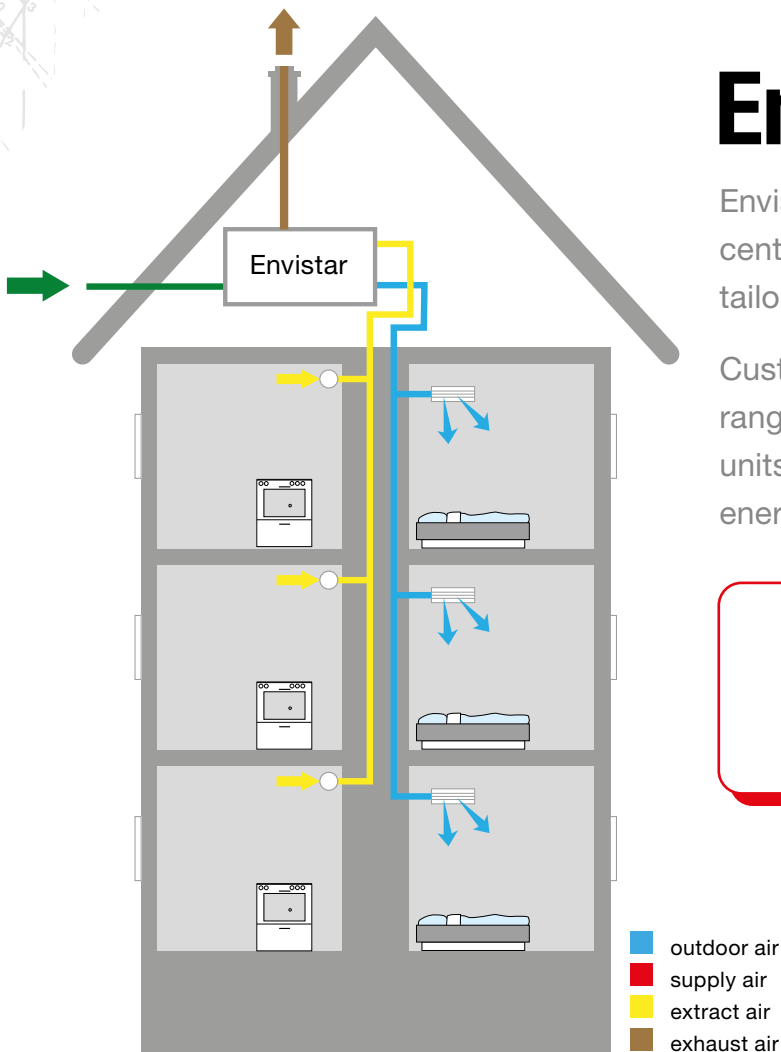

### Simple ownership

Do you recognise yourself in any of the situations on previous pages? Or are you in the process of constructing a new building? If so, we recommend the Envistar Home Concept unit, which is tailored specifically for blocks of flats.

Its central locations aid servicing and monitoring. You will reduce your costs and you do not need to disturb any tenants to inspect the unit.

### High efficiency

Our high-efficiency heat recovery unit can achieve 85% dry temperature efficiency. The fans that drive the unit have a very low SFPv. The Swedish National Board of Housing, Planning and Building recommends an SFPv value of 1.5 kW/m<sup>3</sup>/s.

# ... energy-efficient FTX solution

## Advantages

- Centrally located
- Customised control equipment for blocks of flats
- High-efficiency counter-flow exchanger that can achieve a dry temperature efficiency of 85 per cent
- Components with low pressure drop
- Energy-efficient fans, low SFPv value  
We recommend a SFPv value lower than 1.5 kW/m<sup>3</sup>/s, with duct pressure 200–250 Pa
- Each unit can be used for 6–240 flats
- Simple for property owners
- Simple for installation contractors
- Simple for tenants

Centrally located FTX units create the best indoor climate and have the lowest energy consumption.



# Envistar<sup>®</sup> Top

More and more customers are choosing a unit with a counter-flow exchanger from our Home Concept. This type of energy recovery unit is also available with our top connected unit. These units are not only suitable for homes, but also for other projects. One of the biggest advantages is that the air flows are separate, which removes the risk of odour transfer between flats. The Envistar Top series is available in a one-piece configuration or in sections, and has been adapted to allow transport through narrow door openings and tight passages.



- 8 sizes, air flow 0.10–2.80 m<sup>3</sup>/s
- Energy recovery unit – rotor or counter-flow exchanger
- Air flow with counter-flow exchanger 0.13–1.15 m<sup>3</sup>/s  
Air flow with rotor 0.10–2.0 m<sup>3</sup>/s
- Can be controlled and monitored using the IV Produkt AHU Controls app or using the IV Produkt Cloud service
- High-efficiency counter-flow exchanger that can achieve a dry temperature efficiency of 85 per cent
- Counter-flow exchanger with unique patented defrosting technology – Optimised Defrosting System (ODS) – which ensures the highest possible annual temperature efficiency
- No risk of odour transfer with counter-flow exchanger
- Fans with high-efficiency EC motors
- Deep-pocketed bag filter with low pressure drop and long service life



# When **space** is crucial

Envistar Top saves up to 75 per cent of floor space compared to a traditional installation. This makes Envistar Top the most economic and energy-efficient solution for the available floor space.

The image shows a high-efficiency installation when the unit is positioned behind double doors. The fan room for the unit only needs 2 m<sup>2</sup> floor space, and service can be carried out from the adjoining surface in front of the doors.



## We want to make life **easier** for the installation contractor



We are continuously developing our units according to requests from users and installation contractors, and we know that it can be complicated and expensive to get the unit into the building. That is why the series has been adapted for transportation through an opening 900 mm wide and some of the sizes fit through an opening 800 mm wide.

We have come up with the unique solution of splitting the counter-flow exchanger widthways for Envistar Top. We hope this will make it easier for you to get the unit into the building, and even into narrow lifts.

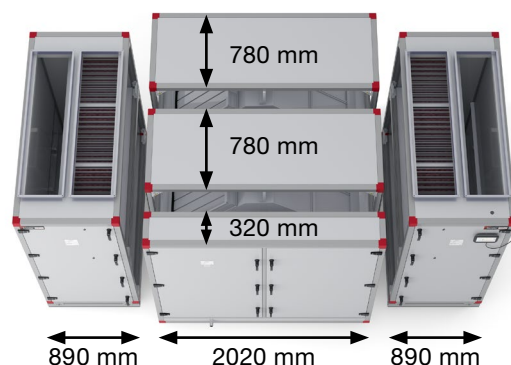

Envistar Flex is available with a wide range of fans, motors and heat recovery units to ensure everything you need for energy-optimised air handling.

Units with Home Concept currently supply more than 375,000 flats and are a great success. The main reason for this is the patented defrosting, which is adapted for homes. This helps achieve the best possible annual temperature efficiency.

Envistar Flex can be delivered in sections to facilitate transport. Most modules will fit through a 900 mm wide opening.



- 10 sizes with counter-flow exchanger  
6 sizes with rotor
- Air flow with counter-flow exchanger 0.13–6.50 m<sup>3</sup>/s  
Air flow with rotor 0.10–2.70 m<sup>3</sup>/s
- Can be controlled and monitored using the IV Produkt AHU Controls app or using the IV Produkt Cloud service
- Fans with PM motors with speed control via frequency inverter or EC control
- Outdoor configuration

## Patented defrosting

One of the advantages of having a counter-flow exchanger as a heat exchanger is the separate air flows, which remove the risk of odour transfer between the flats.

Counter-flow exchangers from IV Produkt are also equipped with our unique, patented defrosting technology – ODS. This ensures the best possible temperature efficiency over the year.



# Housing with increased **comfort**

Flats built today are becoming more and more energy-efficient. Houses are becoming more compact and often have large glass surfaces. This leads to a warmer indoor climate.

To achieve a better indoor climate, our integrated air handling unit, EcoCooler, can be selected for the centrally located air handling unit Envistar Flex.

The cooling unit lowers the temperature of the air supplied to the flats. On a warm summer's day, the temperature supplied to the flats can be lowered by 6–10 degrees. If the door to the bedroom – into which the air is often supplied – is closed, a cool and comfortable indoor climate will be achieved.



## Home Concept with integrated cooling unit EcoCooler

**Installation cost** for EcoCooler approx. **500 €/flat**

**Running cost** for centrally controlled supply air approx. **15–20 €/flat/year**

The temperature drop in each flat depends on solar gains, air flow and internal loads. This means the heat that is generated in the flat in the form of people, lighting, cooking, computers, etc. The inlet temperature is controlled centrally and cannot be controlled individually in each flat/room.



Air handling unit Envistar Flex with Home Concept and integrated cooling unit EcoCooler.

# We protect resources

Air that is extracted via ventilation systems often contains a lot of heat. We do not want to let this heat go to waste and aim to recover as much of it as possible. We do this by using various types of heat exchanger.

We recover the heat from the extract air and use it

to heat the cold air from outside.

There are different types of high-efficiency heat recovery units in the Envistar Home Concept range.

This allows us to offer the most optimal solution while also protecting the Earth's resources.

## Counter-flow exchanger

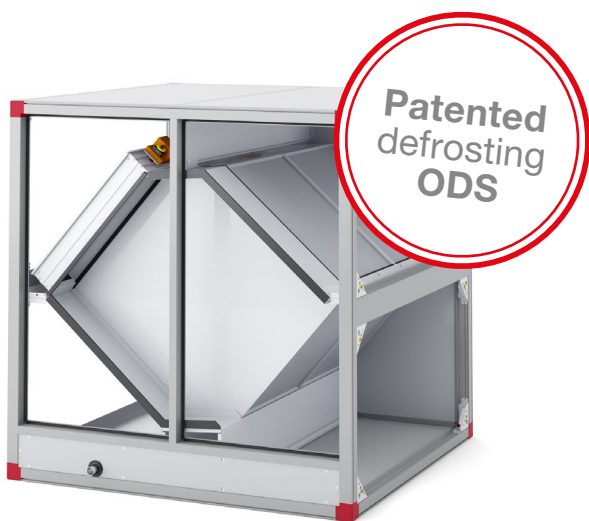

- High-efficiency heat recovery unit that can achieve a dry temperature efficiency of 85 per cent
- Patented defrosting technology – ODS Optimised Defrosting System
- Reduced fan power (SFP) in the event of reduced heat recovery requirement
- No risk of odour transfer

## Rotary heat exchanger

Envistar Home Concept can also be supplied with rotors. Air from cooker hoods must not flow through a rotor.



- High-efficiency heat recovery unit with a dry temperature efficiency of up to 87%
- Continuous monitoring and control of the pressure balance between supply and exhaust air ensures efficient clean blowing
- Optimised rotor speed to reduce the risk of odour transfer
- Active carbon filter, which minimises the risk of odour transfer, as an option
- Filter control function – FLC Filter Lifetime Control – makes it possible to set alarms for replacing the carbon filter

# Which **solution** will you choose?

## Counter-flow exchanger

- Low maintenance costs
- No risk of odour transfer
- Simple ownership
- Pre-heater is recommended for external temperatures lower than  $-26^{\circ}\text{C}$ .

## Rotary heat exchanger

- Lower energy consumption
- Lower risk of freezing
- Short overall dimensions
- Higher maintenance costs
- Air from cooker hoods must not flow through a rotor

**90%** choose a counter-flow exchanger

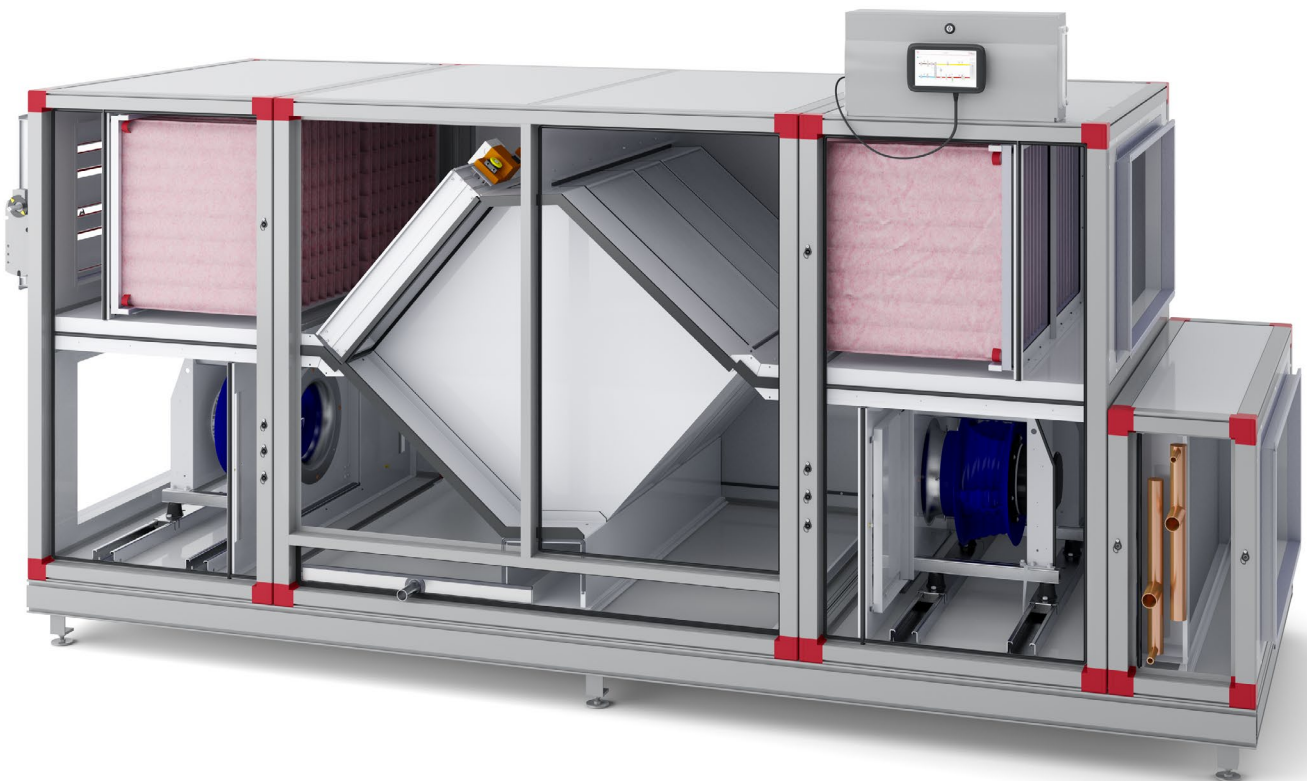

## Bear in mind ...

... that counter-flow exchangers and rotors should be adapted and tested for homes.

# Temperature efficiency

When discussing temperature efficiencies, it is important to differentiate between dry and wet temperature efficiencies. A dry temperature efficiency of 85 per cent is equivalent to a wet temperature efficiency

of over 90 per cent. The wet temperature efficiency is theoretical and may not work in practice due to freezing. We have tried to illustrate this in the diagram below.

## Temperature efficiency

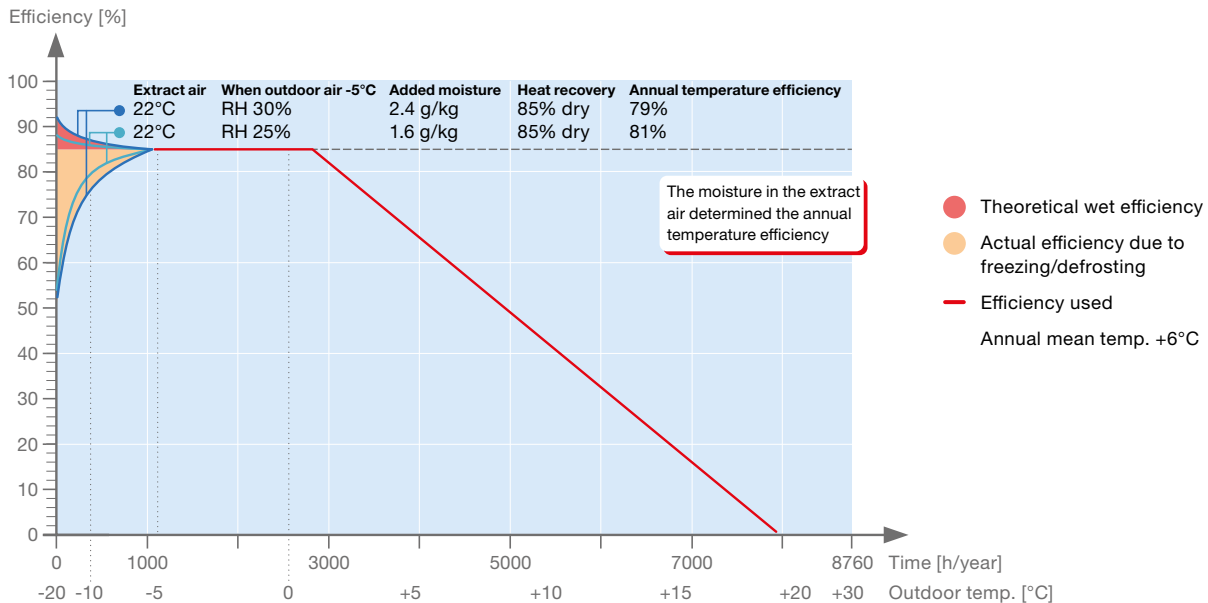

## Energy recovery, counter-flow exchanger

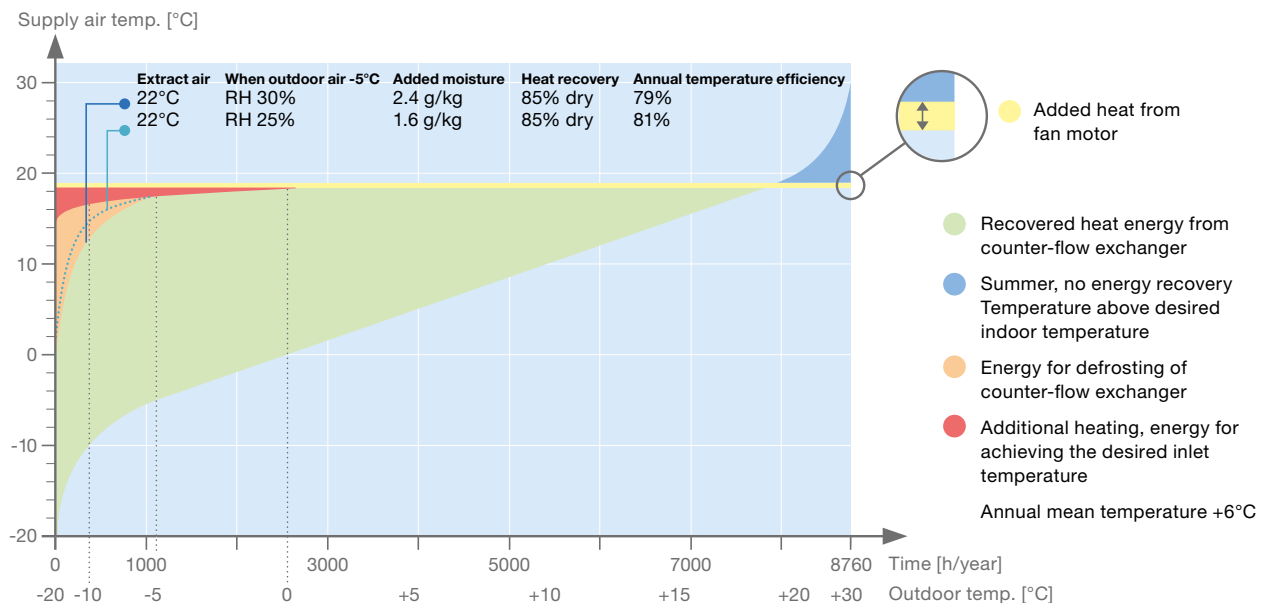

Do not be misled by various “marketing tricks” that specify different efficiencies for the same heat exchanger. We always specify the **dry efficiency**, which is also the only efficiency that can be measured during an inspection.

**Same heat exchanger reported on in different ways**

Dry, in accordance with EN308	85%	Correct!
Wet	86–93%	
Wet incl. motor heat	88–95%	
Annual energy incl. motor heat	92–97%	

# Installation **in reality**



Counter-flow exchanger in sections, adapted to allow transport in through narrow door openings and tight passages.

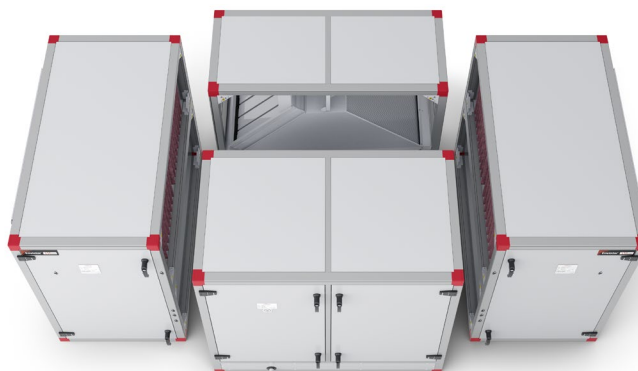

**Envistar**® **home concept**



## Before installation

FTX unit with heat bank

Temperature efficiency: approx. 40%  
 SFPv value: approx. 3.5 kW/m<sup>3</sup>/s  
 Energy consumption: 37 kWh/m<sup>2</sup>/year



## After installation

FTX unit with counter-flow exchanger

Temperature efficiency: 85%  
 SFPv value: 1.23 kW/m<sup>3</sup>/s  
 Energy consumption: 9 kWh/m<sup>2</sup>/year  
 Payback time: 3.9 years

**Envistar**® **home concept**

# Top performance

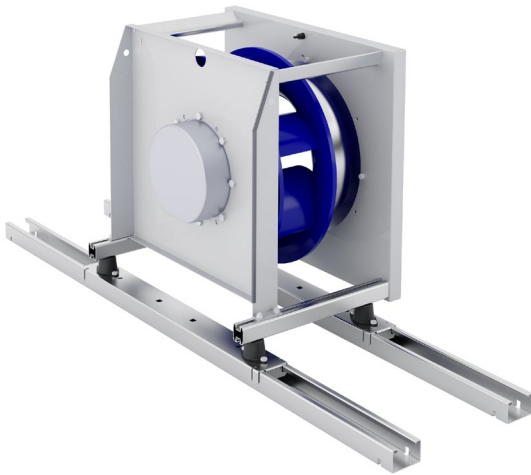

## Energy-efficient fans with PM motors and EC control

- Direct-driven and speed-controlled fans
- Very high efficiency
- Fans with very low noise level
- The fan is mounted on rails, making it easy to pull out for easy servicing
- Each unit size is available with various fans and motors to achieve the lowest possible SFPv value through optimised fan efficiency and reduced electricity consumption

## Cross-flow section

- Cross-flow sections are available as accessories, and adapt air flows for existing installations
- The extract air must always come from above and flow down through a counter-flow heat exchanger

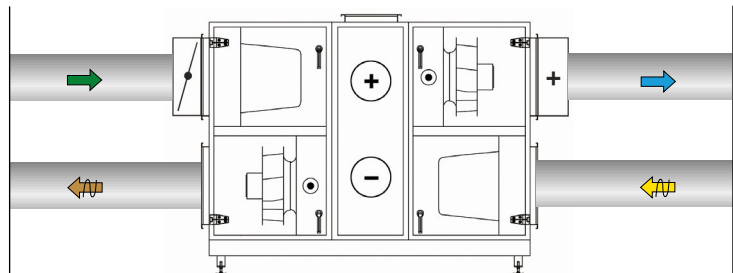

Existing installation

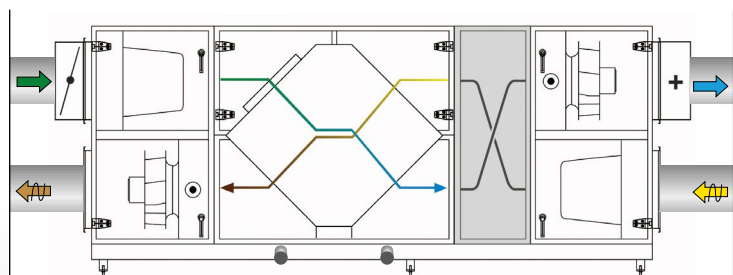

New installation, with cross-flow section

## Filter

- Deep-pocketed bag filter
- Low pressure drop properties
- Long service life – few replacements
- Industry-standard filter sizes where possible

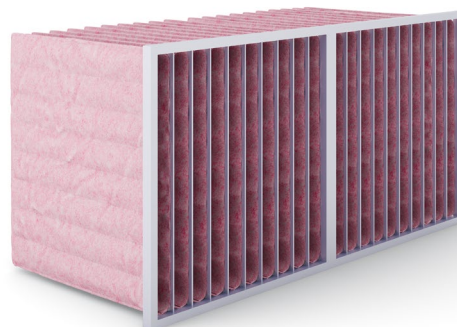

# New casing gives added **benefits**

Thanks to our rapid pace of development, we are continually getting better at energy-optimised air handling.

This product development has resulted in the entire range being given a casing with an even better design, shape and energy performance.

We have worked on innovative solutions throughout the entire manufacturing process, enabling us to offer units with even lower heat loss. According to the EN 1886 standard, the classification of the casing is determined by the U value. The lower the number, the better the insulation capacity.

## ThermoLine

Two configurations of the casing are available. The standard version is classified under casing class T3, which has a U value of 1.24\*. For the best energy performance, you can now also choose ThermoLine, which is a class T2 casing and has a U value of 0.88\*.

A casing class of T2 reduces cold bridges. In fan rooms with high air humidity, this reduces the risk of condensation forming on the unit casing.

**Class T2: U value 0.5–1.0**  
**Class T3: U value 1.0–1.4**

## Indoor units

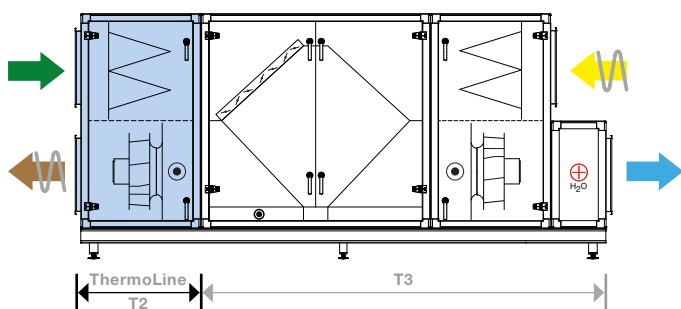

A major advantage of the recently-developed casing design is that we can choose different casing classes for selected parts of the unit. For example, we can select the inlet and exhaust air sections for a **ThermoLine – T2** indoor unit to offer the most energy-efficient and cost-effective solution.

## Outdoor units

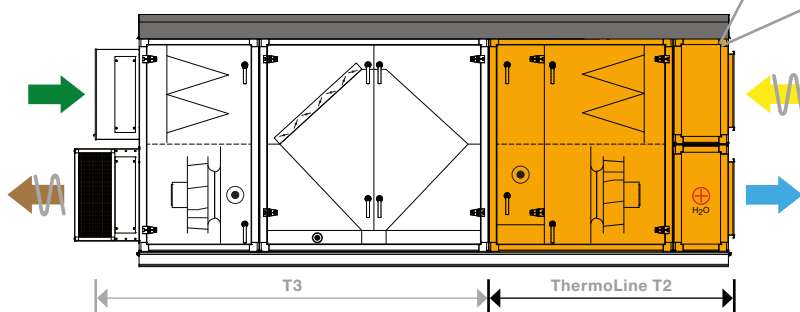

The black plastic insert in the profile breaks the cold bridge and is a characteristic of the **ThermoLine – T2** casing.

In the case of outdoor air handling units, the supply and extract air sections are the primary cause of heat loss. Selecting these sections in **ThermoLine – T2** offers the most energy-efficient and cost-effective solution.

The payback period for ThermoLine depends on the installation's operating conditions and energy prices.

\* Measured in model box in accordance with EN1886.

# Control communication with endless possibilities

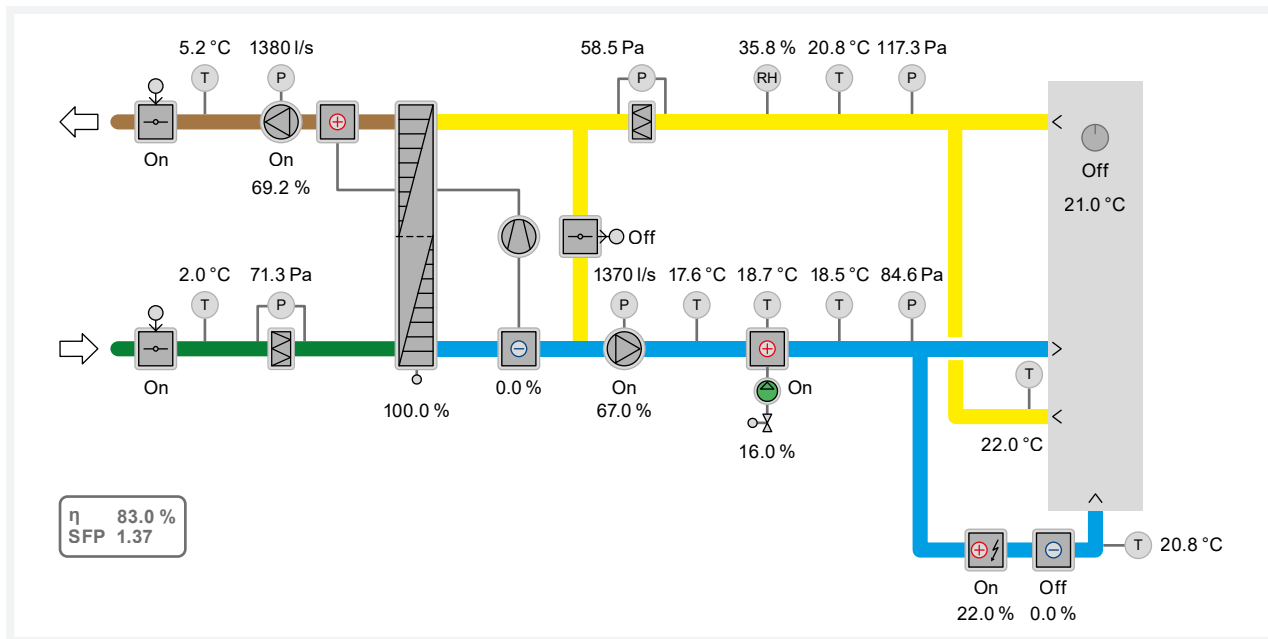

When you order a unit from the Envistar range, you receive a complete air handling unit that has been function-tested and is ready to be commissioned. We are continuously developing the software and adding new smart features, enabling the lowest energy use and the best indoor climate. The functions can be adapted as required and

some examples of application are zone control, various fire functions and dew point control. The unit is supplied with project-specific wiring and control diagrams, and a handset that allows you to optimise flows and temperatures. A hand-held terminal with touchscreen is now available as an optional extra.

## BMS

Building Management System

Modbus BACnet LON OPC



Access via web browser



Cloud service



Hand-held terminal



App for smart units



Hand-held terminal with touchscreen

# Keeping track of your kilowatt hours!

We are now offering an optional extra for our air handling units in the Envistar range in the form of the in-house developed software Energy Watch which helps you to keep track of your kilowatt hours.

Energy Watch is a unique function for monitoring and optimising the energy use in the air handling unit.

You can easily see the meter values and information in the app, the hand-held terminal or in BMS system.



Energy watch measures and shows:

## Heat recovery

- Recovered energy and power
- Heat recovery unit efficiency

## Fans

- Energy input and power
- Specific fan power, SFP/SFPv
- Density correction of the air flow with measurement at four points for the best possible accuracy

## Additional heating

- Energy input and power
- Alarm for leaking heating valve

# Take control using our IV Produkt AHU Controls app

You can now control our unit using the IV Produkt AHU Controls app. You connect the unit to the internal network in the property, if the building has Wi-Fi. If you cannot connect the unit to the internal network, we offer an optional Wi-Fi router for the unit.

- Control your unit easily via smartphone or tablet
- Start up the unit and adjust the values
- React quickly in the event of an alarm
- See event logging and history
- Clear interface and summary flow chart

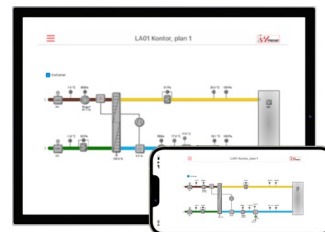

The app is available to download free of charge for iOS och Android™. You can adjust setpoints and settings, see any alarms and much more without needing to be in the plant room.



# Gives you **full control** – wherever you are

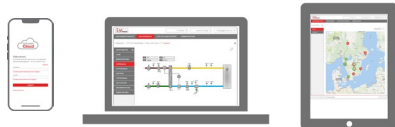

## IV Produkt Cloud service

IV Produkt Cloud is a cloud service for our air handling units with integrated control, in which you and your colleagues will be able to keep track of your systems no matter where you are. The cloud service is always accessible wherever there is internet access. In other cases, there is an optional 4G router.

IV Produkt Cloud is available as a free subscription called Free, and a paid subscription called Service+. The new administrative service Digital Wallet helps you manage your subscriptions.

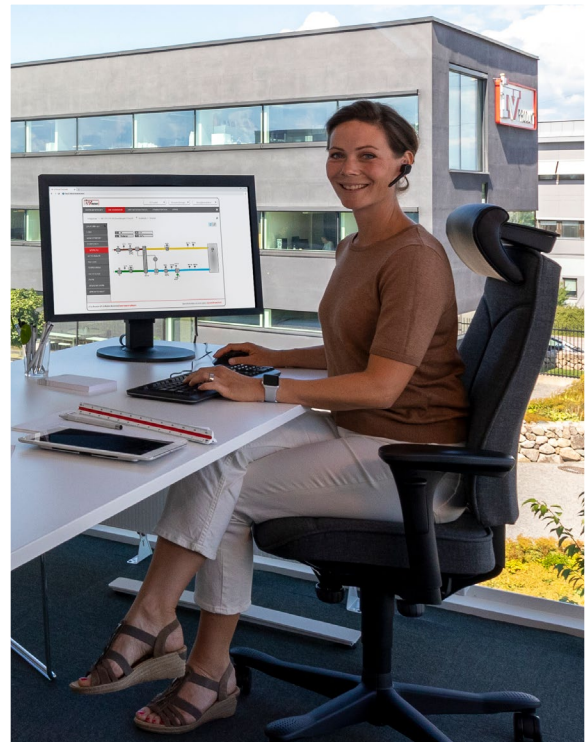

- Completely free subscription
- See status and flow chart and reset alarms
- Service+ included the first month



- Full access to change control functions and adjust values
- Alarm notifications, history and upgrades
- Good for balancing and commissioning
- Remote support capability from us at IV Produkt

## Lower your costs with Digital Wallet

For you who have multiple handling units and wish to manage your own account. Switch between Free and Service+ subscriptions as the requirements of the system change.

**new!**



# Functional in the event of fire

Envistar Home Concept has numerous functions for use in the event of a fire. Using control equipment, adjustments can be made to fans that should be in operation and dampers that need to be controlled to quickly get rid of smoke.

The various functions can be selected during the design of the AHU in our selection program IV Produkt Designer. Feel free to contact one of our sales staff for help with your specific project.

## Example of fire functions

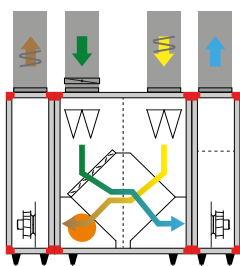

Smoke-bypass connected on rear of unit to extract air fan

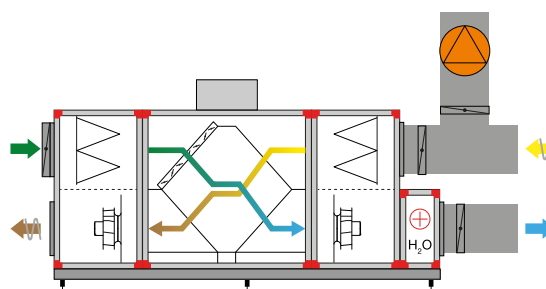

Smoke extract fan exercise cycle using of separate smoke extract fan

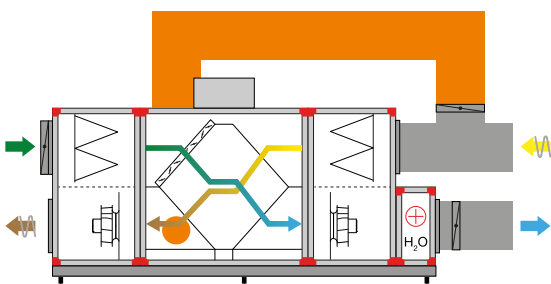

Smoke-bypass connected on rear of unit to extract air fan

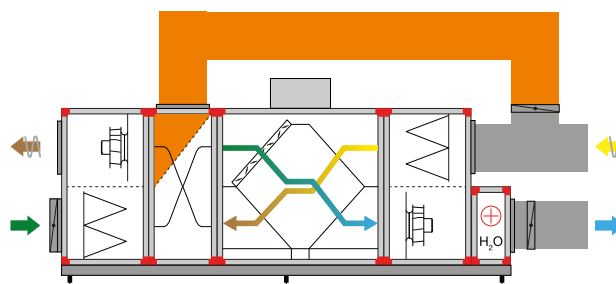

Connection in roof for smoke-bypass with cross-flow section

# Make everyday life **easier**

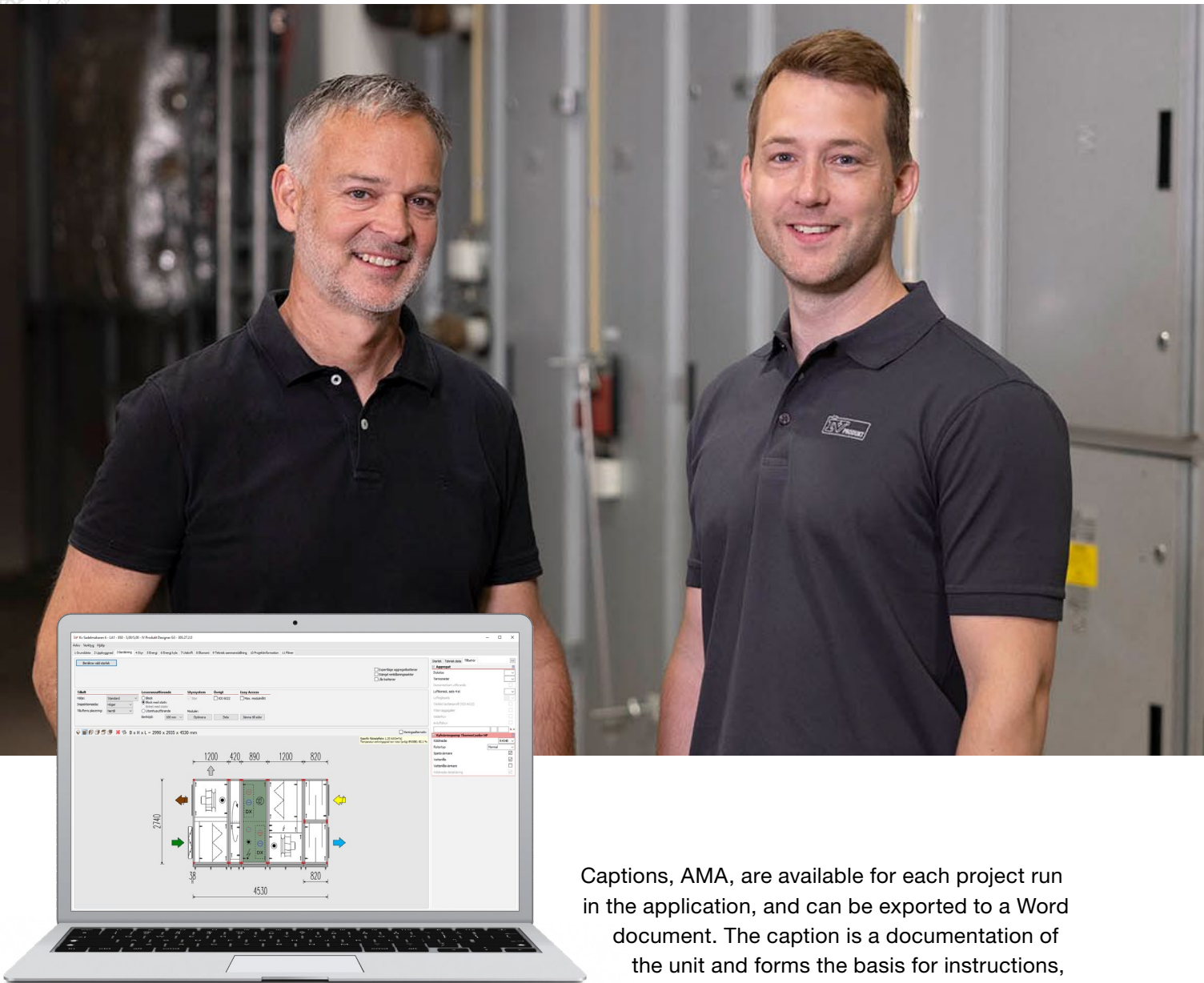

We want to make everyday life easier for consultants, installers and contractors. Our program **IV Produkt Designer** will help design and dimension the air handling unit.

We have developed a tool which enables you to perform calculations using the data for your project. Using the program **IV Produkt Designer**, you can easily and quickly design your unit to meet different needs. You will receive a dimension drawing with technical data containing specific fan power values, temperature efficiency, sound data and much more.

Captions, AMA, are available for each project run in the application, and can be exported to a Word document. The caption is a documentation of the unit and forms the basis for instructions, operation and maintenance, and can be used to copy information to project documents. There is also a plugin for **IV Produkt Designer** to connect the program to **MagiCAD** for **AutoCAD**. The file contains all data that is needed for planning. Another plugin makes it possible to export project files to **Revit**.

You can also perform a separate **LCC** and investment calculation for an existing or new unit in the program. This gives you the opportunity to calculate the profitability of replacing a unit.

**IV Produkt Designer** can be downloaded free of charge from [www.ivprodukt.com](http://www.ivprodukt.com), or contact us and we will of course be happy to help you.



# The most profitable sustainability investment

It is easy to make investment decisions with calculations from IV Produkt Designer. The calculation includes accounting of

- Energy savings
- Economy och payback-period
- Calculation of increased property value

An older ventilation unit that appears to be in good condition may be unexpectedly profitable to replace. It is easy to calculate energy savings and payback period when replacing e.g. a unit from the 1990s. Given that it is over 20 years old, today's units are significantly more efficient.

On this page and the next you can see an example of a completed project with replacement of older ventilation units.

## ENERGY

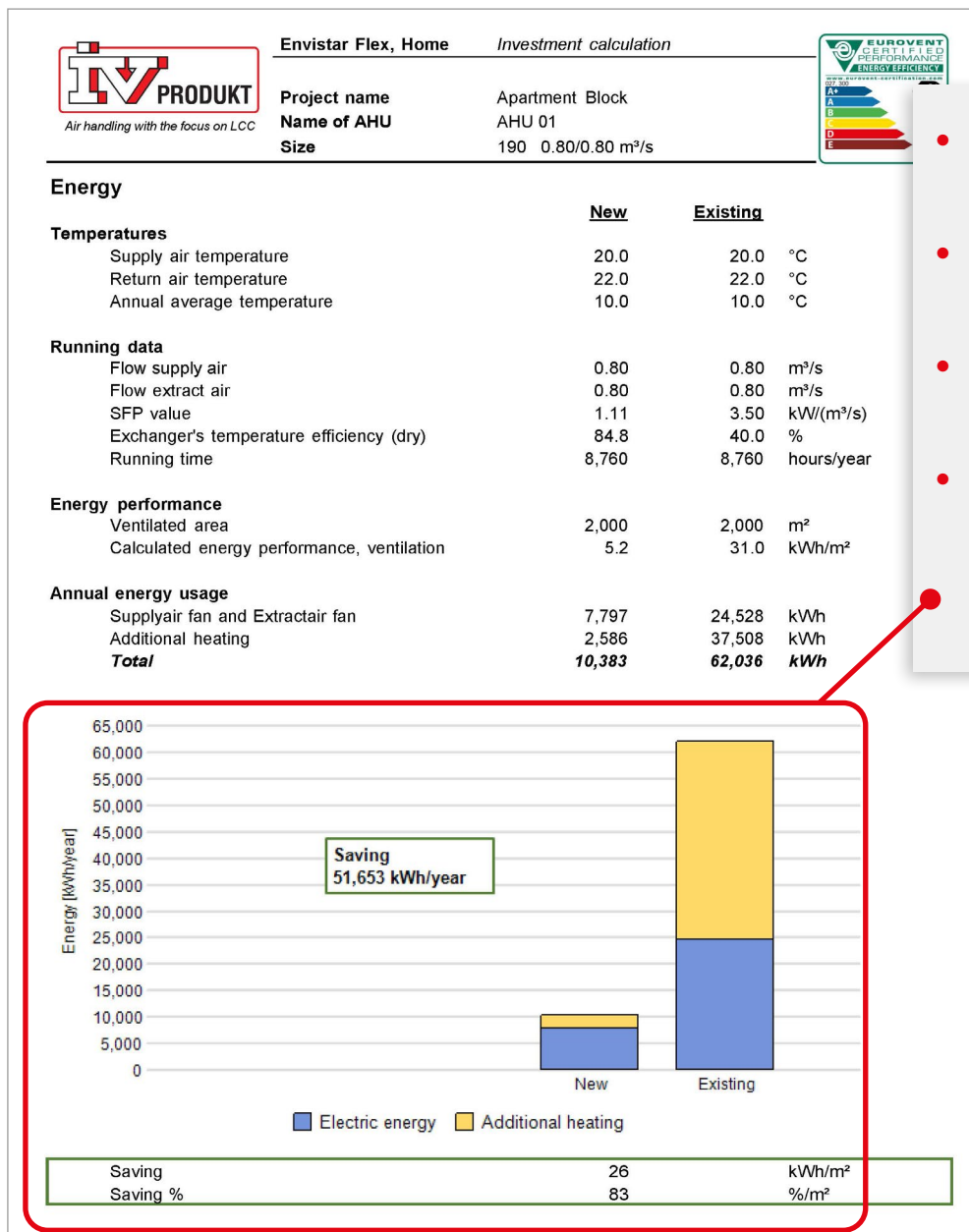

- Savings: **51,600** kWh/year
- Equivalent to **26** kWh/m²/year
- Means savings of 80%
- Can be used in the sustainability report.

# ECONOMY

- Payback period: **4.9** years
- Energy cost savings year 1: approx. **5,300€**
- Savings over 20 years: approx. **121,000€**
- The increase in property value is three times the investment cost.

Economy		
<b>Economic factors</b>		
Energy price EI	0.15 EUR/kWh	
Expected annual price increase electricity	3.0 %	
Energy price add heat	0.08 EUR/kWh	
Expected annual price increase heating	3.0 %	
Life expectancy	20 years	
Running time	8,760 hours/year	
<b>Cost summary, Lifetime</b>		
Investment	<b>New</b> 35,000 EUR	<b>Existing</b> 7,500 EUR
Energy cost 20 years	38,463 EUR	186,790 EUR
Cost summary	73,463 EUR	194,290 EUR

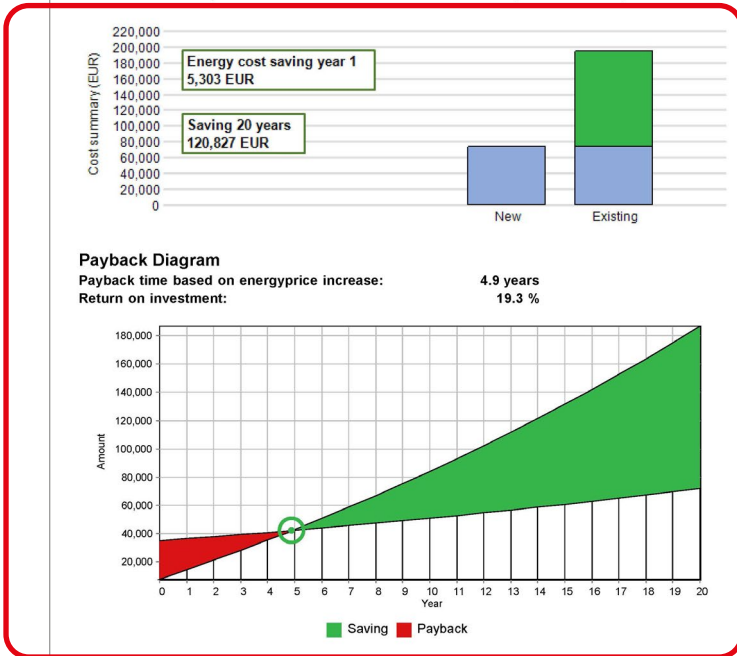

### Payback Diagram

Payback time based on energy price increase: **4.9 years**  
Return on investment: **19.3 %**

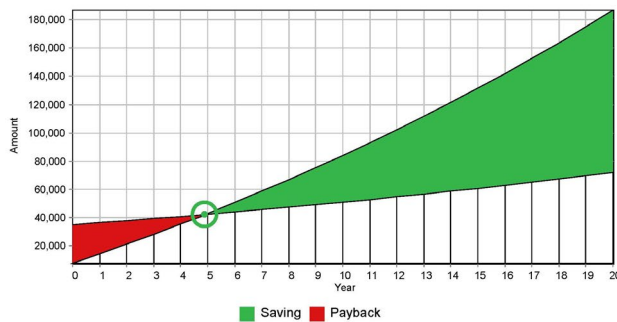

# PROPERTY VALUE

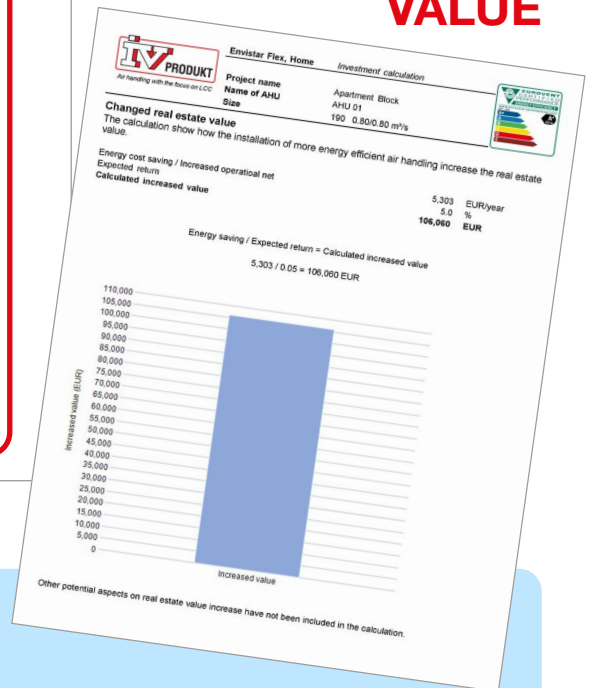

## Increase in property value

Energy savings reduce the property's total operating costs. The net operating income is calculated by deducting operating costs from total rental income. If you divide the net operating income by the property's required rate of return, you get the property value.

A higher net operating income thus leads to an increase in property value. And a higher property value creates opportunities for making new investments.



net operating profit

required rate  
of return %

5,300€

5 %

=



property value

= 106,000€

# Envistar<sup>®</sup> Top

## Configuration with rotor

Right or left handed configuration selected during planning.  
The below is an example of a right-handed configuration.

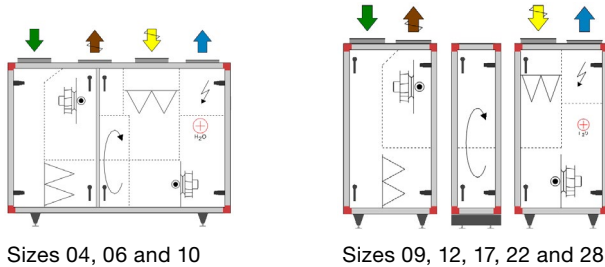

## Technology

- Duct connections upward
- 8 sizes
- Air flow 0.10–2.8 m<sup>3</sup>/s
- Filter control carbon filter – FLC
- EC motors with very high efficiency

- Control equipment  
Siemens Climatix
- Energy optimisation  
function – ECO
- Rotary heat exchanger
- Saves up to 75% floor space
- Damper for recirculated  
air operation as an option

## Alternative duct connection

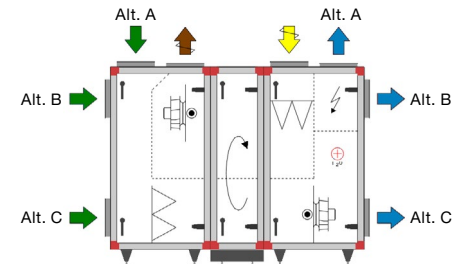

## Available external pressure

See IV Produkt Designer for  
object-specific data.

## Duct accessories

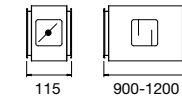

## Capacity and technical data

Size	Dimensions (mm)				Air handling unit excluding cooling unit				
	Width	Height	Length	Duct connection	Air flow (m <sup>3</sup> /s) <sup>a</sup>			External fuse protection <sup>c</sup>	Weight <sup>d</sup> (kg)
					Min	SFP <sub>v</sub> 1,5	Max <sup>b</sup>		
04	748	1365	1570	∅ 250 500 × 200 <sup>g</sup>	0,10	0,30	0,43	10A	255
06	890	1365	1720	600 × 250	0,15	0,50	0,68	10A	305
09	1020	1435	2000 <sup>e</sup>	700 × 300	0,20	0,70	0,98	10A	450
10	1020	1435	1990	700 × 300	0,20	0,70	0,98	10A	395
12	1200	1530	2000 <sup>e</sup>	900 × 300	0,25	0,98	1,20	10A	530
17	1400 <sup>i</sup>	1835	2200 <sup>f</sup>	1000 × 350	0,30	1,53	1,80	10A	685
22	1616 <sup>i</sup>	1885	2200 <sup>f</sup>	1200 × 350	0,40	2,00	2,30	16A	825
28	1880 <sup>i</sup>	1995	2200 <sup>f/h</sup>	1400 × 350	0,40	2,65	3,00	20A	960

a - For units with dampers, F7 filter supply air, M5 filter extract air, rotor, water coil 60/30°C with supply air temp +20°C and duct pressure: 150 Pa (size 04), 200 Pa (size 06-28)

b - Technical Maximum Flow

c - 3×400 V+N+PE 50 Hz, fuse with type C characteristics

d - Including water coil heating (not filled with liquid)

e - Supplied in three sections that have a max. width of 790 mm

f - Supplied in three sections that have a max. width of 890 mm

g - Top 04 with cooling unit has duct connection 500 × 200 mm

h - For length see the product selection program  
IV Produkt Designer

i - Above the rotor, width increases by 50 mm.

For object-specific data,  
see the product selection program  
IV Produkt Designer

## Configuration with counter-flow exchanger

Right or left handed configuration selected during planning.  
Below is an example of a right-handed configuration.

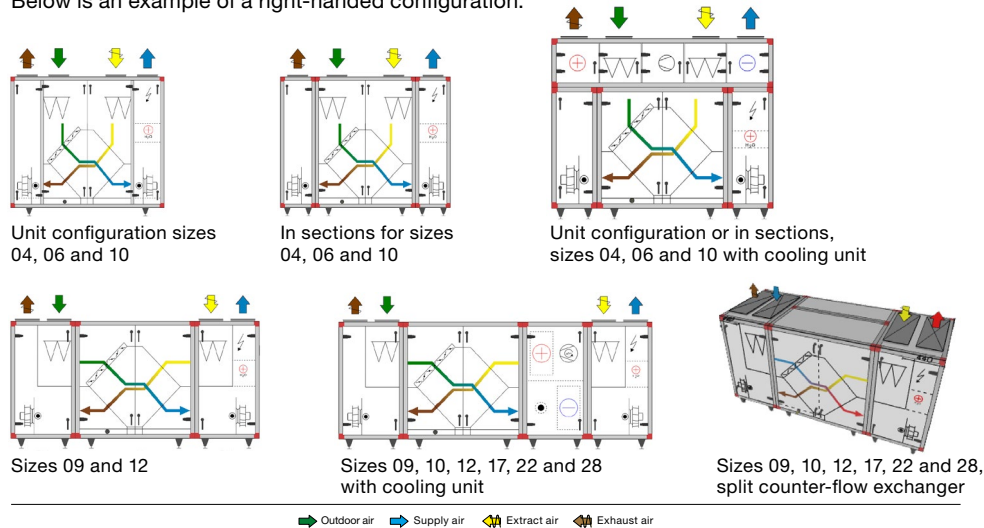

## Technology

- Duct connections upward
- 8 sizes
- Air flow 0.13–2.80 m<sup>3</sup>/s
- EC motors with very high efficiency

- Control equipment Siemens Climatix
- Energy optimisation function – ECO
- Energy recovery unit – counter-flow exchanger
- Saves up to 75% floor space

## Available external pressure

See IV Produkt Designer for object-specific data.

## Duct accessories

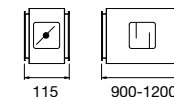

## Alternative duct connections

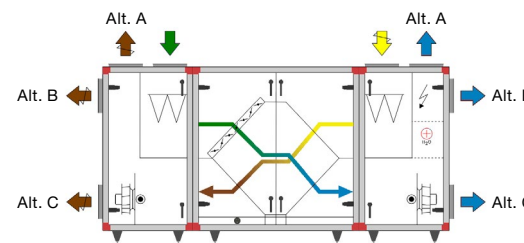

## Smoke-bypass

Sits on the heat exchanger exhaust air section on the reverse side of the unit.

- Size 04      ø 200 mm
- Size 06      ø 250 mm
- Size 09      ø 315 mm
- Size 10      ø 315 mm
- Size 12      ø 315 mm
- Size 17      ø 315 mm
- Size 22      ø 500 mm
- Size 28      ø 500 mm

## Capacity and technical data

Size	Dimensions (mm)					Air handling unit					Air handling unit with integrated cooling unit							
	Width	Height excl./incl. cooling unit	Length, unit	Length, in sections	Duct connection	Air flow (m <sup>3</sup> /s) <sup>a</sup>			External fuse protection <sup>c</sup>	Weight (kg) <sup>d</sup>	Power variant	Air flow (m <sup>3</sup> /s) <sup>a</sup>			Cooling power (kW)	Refrigerant volume <sup>e</sup> (kg)	External fuse protection <sup>c</sup>	Weight <sup>d</sup> (kg)
						Min	SFP <sub>v</sub> 1,5	Max <sup>b</sup>				Min.	SFP <sub>v</sub> 1.6	Max. <sup>b</sup>				
04	748	1540	1820	2067	Ø 315 / 500 × 200	0,13	0,36	0,42	10A	310	2V	0,12	0,35	0,35	6,4	1,10	10A	361
06	890	1625	1960	2207	Ø 315 / 600 × 250	0,18	0,49	0,60	10A	390	2V	0,15	0,49	0,60	11,4	1,70	20A	416
09	1020	1530	–	3040	700 × 300	0,25	0,69	0,95	10A	580	2V	0,25	0,75	0,95	14	1,90	25A	541
10	1020	1990/2020	2215	2466	700 × 300	0,25	0,73	0,95	10A	610	2V	0,25	0,75	0,95	17,9	2,10	25A	547
12	1200	1530	–	3040	900 × 300	0,30	0,83	1,15	10A	650	2V	0,30	0,92	1,15	21	3,20	25A	616
17	1400	1835	–	3235	1000 × 350	0,42	1,40	1,65	10A	870	2V	0,50	1,35	1,65	28	4,10	25A	1145
22	1616	1885	–	3800	1200 × 350	0,55	1,80	2,25	16A	1185	2V	0,68	1,75	2,0	41	5,70	40A	1500
28	1880	1995	–	3800	1400 × 350	0,55	2,30	2,80	20A	1410	1V / 2V	0,80 / 0,92	2,25	2,6	46 / 52	7,50	50A	1760

a - For units with dampers, F7 filter supply air, M5 filter extract air, counter-flow exchanger, water coil 60/30°C with supply air temp +20°C and duct pressure: 150 Pa (size 04), 200 Pa (size 6-12)

b - Technical Maximum Flow

c - 3×400 V+N+PE 50 Hz, fuse with type C characteristics

d - Including water coil heating (not filled with liquid)

e - Refrigerant R410a

For object-specific data, see the product selection program IV Produkt Designer

## Configurations

The positioning of connections for outdoor air, supply air and smoke-bypass may be selected during planning. Below there are examples of combination options for right-handed indoor configuration. The unit may also have a left-handed configuration and outdoor configuration. The counter-flow exchanger generally always has extract air on top, but the cross-flow section makes it possible to switch the air direction and choose the unit in a number of different combinations.



## Technology

- 10 sizes
- Air flow 0.11–4.5 m<sup>3</sup>/s
- Rotary heat exchanger or counter-flow exchanger
- PM motors with very high efficiency
- Indoor or outdoor configuration

## Control equipment Siemens Climatix

- Pressure/air flow control
- Pressure-controlled purging function rotor
- Optimised defrosting function – ODS
- Energy optimisation function – ECO
- Fire functions

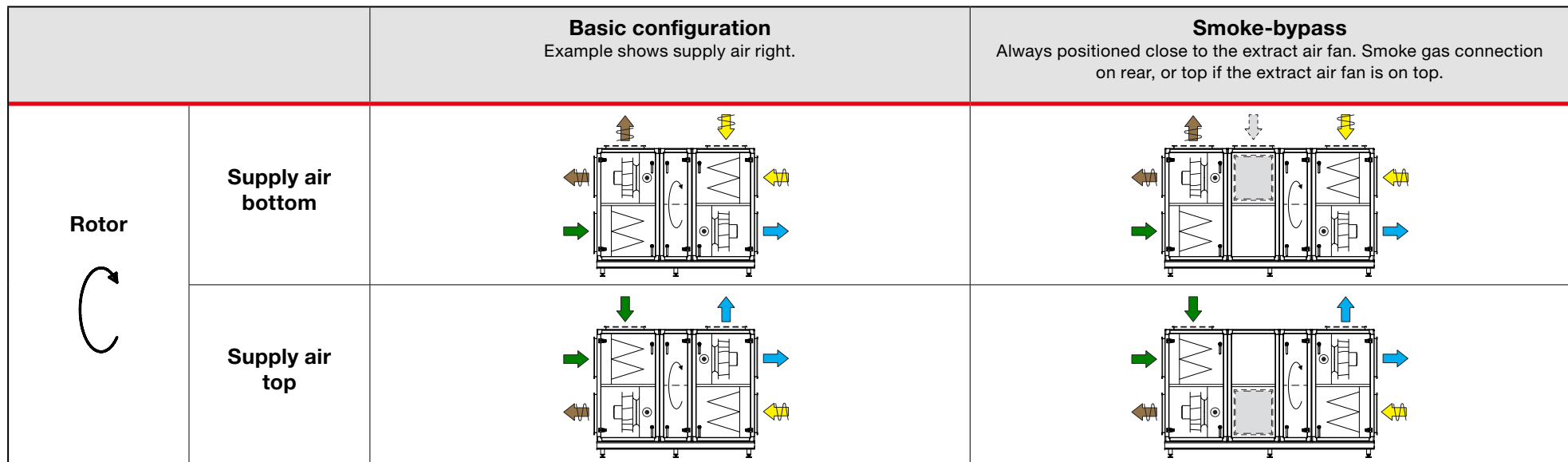

## Capacity and technical data

Size	Cross-section dimensions (mm)			Length (mm)		Air flow (m <sup>3</sup> /s) <sup>a</sup>			External fuse protection <sup>e</sup>	Weight basic configuration (kg)
	Width <sup>b</sup>	Height <sup>c</sup>	Duct connection	Fan unit	Rotor	Min.	SFPv 1.5	Max. <sup>d</sup>		
060	890	960	300 × 500	670	420	0.11	0.38	0.55	10 AT	373
100	1,020	1,090	300 × 700	670	420	0.17	0.70	0.90	10 AT	415
150	1,120	1,470	500 × 800	820	420	0.29	1.10	1.32	10 AT–16 AT	585
190	1,400	1,470	500 × 1,000	820	420	0.38	1.56	1.88	10 AT–16 AT	675
240	1,400	1,686	600 × 1,000	890	420	0.47	1.97	2.15	10 AT–25 AT	780
300	1,616	1,686	600 × 1,200	890	420	0.54	2.40	2.70	10 AT–25 AT	865

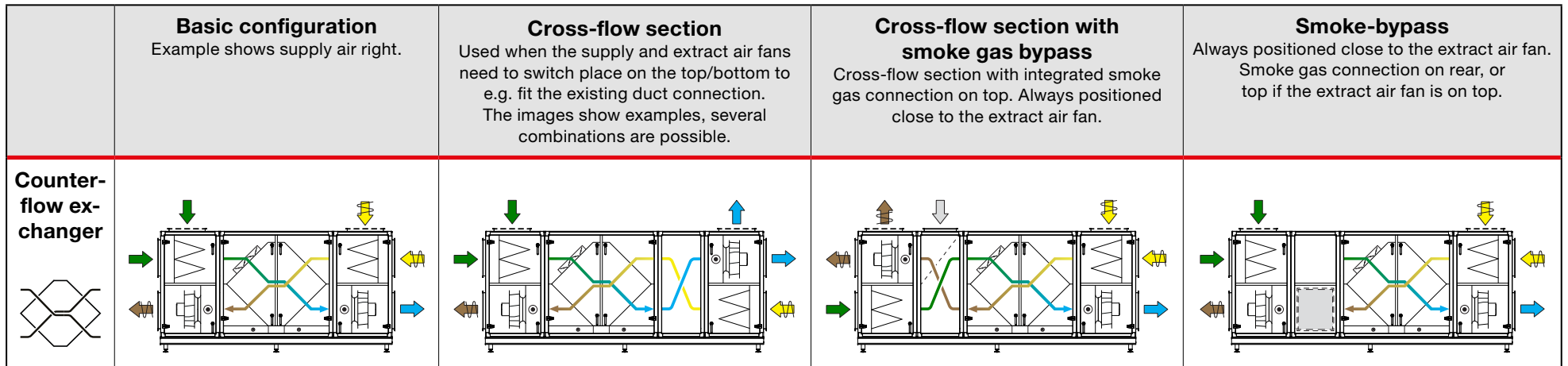

### Duct accessories

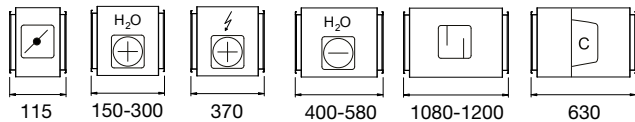

### Bear in mind...

- Connection for smoke-bypass may be on top or on rear as shown in the example. Connection always made between exchanger and extract air fan.
- Permitted smoke temperature is max. 70°C for at least 1 h for sizes 060–360 och max. 60°C for at least 1 h for the sizes 480 and 600.
- Connections in top not possible for outdoor configuration.

### Capacity and technical data

Size	Cross-section dimensions (mm)			Length (mm)			Air flow (m <sup>3</sup> /s) a			External <sup>e</sup> fuse protection	Weight basic configuration (kg)
	Width <sup>b</sup>	Height <sup>c</sup>	Duct connection	Fan unit	Counter-flow exchanger	Cross-flow section/ Smoke-bypass	Min.	SFPv 1.5	Max. d		
060	890	960	300 × 500	670	970	442	0.13	0.32	0.40	10 AT	365
100	1,020	1,090	300 × 700	670	1,270	442	0.20	0.51	0.62	10 AT	460
150	1,120	1,470	500 × 800	820	1,570	642	0.33	0.87	1.12	10 AT–16 AT	660
190	1,400	1,470	500 × 1,000	820	1,570	642	0.42	1.05	1.44	10 AT–16 AT	765
240	1,400	1,686	600 × 1,000	890	2,020	820	0.48	1.62	1.90	10 AT–25 AT	950
300	1,616	1,686	600 × 1,200	890	2,020	820	0.55	1.89	2.25	10 AT–25 AT	1,040
360	1,616	2,060	800 × 1,200	1,120	2,320	970	0.66	2.26	2.80	16 AT–25 AT	1,370
400	1,880	1,900	700 × 1,400	890–990	2,020	890	0.66	2.40	3.20	16 AT–25 AT	1,340
480	1,990	2,060	800 × 1,400	1,040–1,270	2,320	970	0.85	2.98	3.50	16 AT–40 AT	1,725
600	2,200	2,270	800 × 1,600	1,040–1,270	2,620	970	1.06	3.50	4.50	16 AT–40 AT	2,090

a - Applies to units with dampers, ePM1-50% / F7 filter supply air, ePM10-60% / M5 filter extract air, water coil 60/30°C with supply air temp +20°C and duct pressure 200 Pa.

b - Control cabinet increases the width by 170 mm on sizes 240 to 600. Above the rotor, width increases by 50 mm.

c - For the stand, an additional 200 mm is required. The control cabinet increases the height by 290 mm for sizes 100 to 190.

d - Technical Maximum Flow

e - At 3 × 400 V+N+PE 50 Hz, fuse protection varies depending on selection of fans/output variants.

For object-specific data, see the product selection program IV Produkt Designer

# Envistar<sup>®</sup> Compact

## Configurations

Right or left handed configuration selected during planning.  
The below is an example of a right-handed configuration.

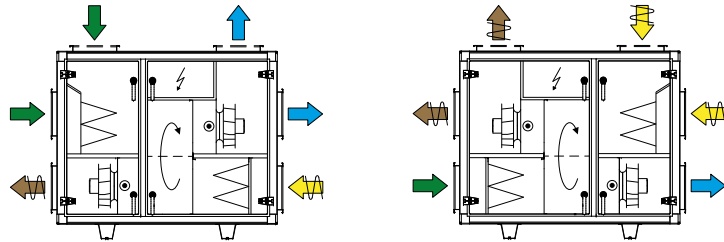

Right-handed configuration  
supply air on top

Right-handed configuration  
supply air on bottom

 Outdoor air     Supply air     Extract air     Exhaust air

## Technology

- Duct connections on top/side
- 4 sizes
- Air flow 0.1–1.5 m<sup>3</sup>/s (360–5,400 m<sup>3</sup>/h)
- Filter control carbon filter – FLC
- EC motors with very high efficiency
- Control equipment Siemens Climatix
- Energy optimisation function – ECO
- Heat exchanger, rotor adapted for homes
- Indoor or outdoor configuration

## Duct accessories

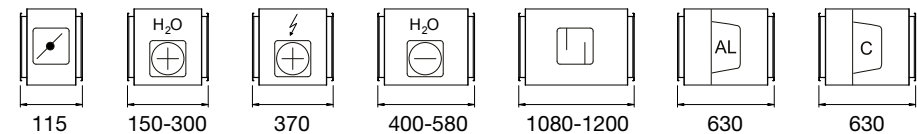

## Capacity and technical data

Size	Dimensions (mm)				Weight (kg)	Air flow (m <sup>3</sup> /s)			External fuse protection
	Width	Height	Length, unit	Duct connection		Min.	SFP <sub>V</sub> 1.5	Max. <sup>a</sup>	
04	748	1,220	1,435	∅ 315	195 <sup>d</sup>	0.10	0.30 <sup>b</sup>	0.38 <sup>b</sup>	3 × 400 V 10 AT
06	890	1,282	1,555	500 × 300	240 <sup>d</sup>	0.15	0.48 <sup>b</sup>	0.58 <sup>b</sup>	3 × 400 V 10 AT
10	1,020	1,383	1,616	700 × 400	305 <sup>d</sup>	0.20	0.64 <sup>c</sup>	0.9 <sup>c</sup>	3 × 400 V 10 AT
16	1,295	1,658	1,860	1,000 × 500	475 <sup>d</sup>	0.30	1.28 <sup>c</sup>	1.52 <sup>c</sup>	3 × 400 V 10 AT

a - Technical Maximum Flow

b - Applies to units with dampers, ePM1-50% / F7 filter supply air, ePM10-60% / M5 filter extract air, rotor, water coil 60/30°C with supply air temp +20°C and duct pressure 150 Pa.

c - Applies to units with dampers, ePM1-50% / F7 filter supply air, ePM10-60% / M5 filter extract air, rotor, water coil 60/30°C with supply air temp +20°C and duct pressure 200 Pa.

d - Excluding water coil heating (duct-mounted).

For object-specific data, see the product selection program IV Produkt Designer

# Knowledge drives the whole industry forwards



At IV Produkt, we will show future generations that ventilation is an industry of the future. Through training, product development and an informative website, we will become a knowledge company and drive the industry forwards.

We are happy to share the knowledge we have accrued with you. Take advantage of our knowledge online, contact us or visit IV Produkt Competence Center, which is an established meeting place for knowledge, conferences and training.

## Documentation – where and whenever you want it

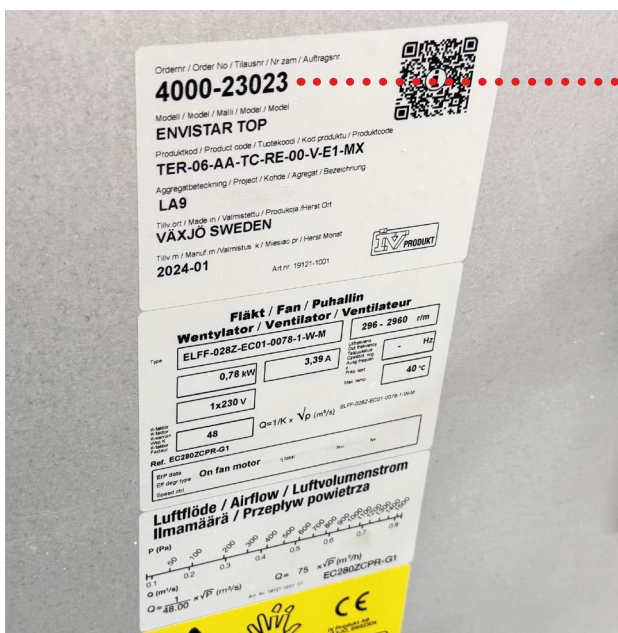

Here, you can find brochures and technical documentation for all our products. ✕

**Order unique Operation & Maintenance**

Enter **your order no** to find unique documentation for your unit.

*Applies to units delivered from 2014 onwards.*

- ▶ Dimensions and weights
- ▶ Performance and power
- ▶ Other documentation

Unique order documentation is created for each unit we supply. This relates to operation and maintenance instructions, building product declaration, technical data, configuration and control diagram. By entering the order number at [ivprodukt.com](http://ivprodukt.com), you can digitally download the documentation for the unit. This service is available for all units delivered from 1 January 2014.

# Projects we have delivered to...

---

Here is just a small selection of the thousands of projects in which, together with consultants and installation firms, we have used our wide range of products to deliver innovative solutions for energy and cost-effective air handling.



Flats in Stockholm, Sweden



The Deichman Bjørvika Library in Oslo, Norway  
Photo: Nicholas Vogt

Flats in Råslätt, Sweden



CA Fastigheter Kalmar, Sweden



Flats in Stockholm, Sweden



Northern Europe's biggest hospital, Aarhus University Hospital, Skejby, Denmark



Kastrup Airport, Copenhagen, Denmark



Harpa Concert Hall, Iceland



Exterium, experience centre in Sälen, Sweden



Titanic Museum in Belfast, United Kingdom

... over  
the years

---



*Air handling with focus on LCC*

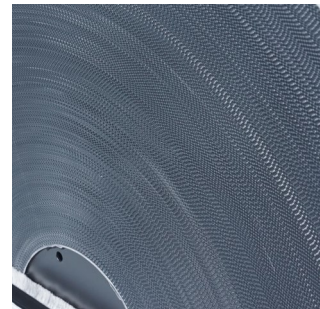
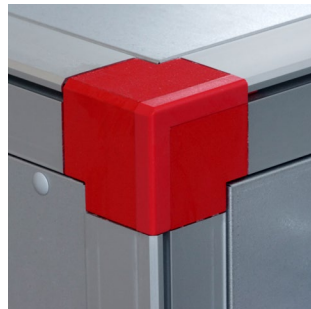
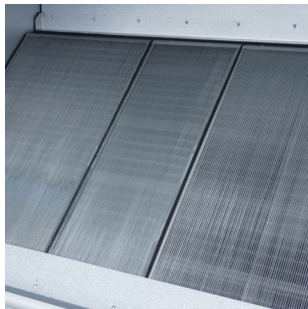
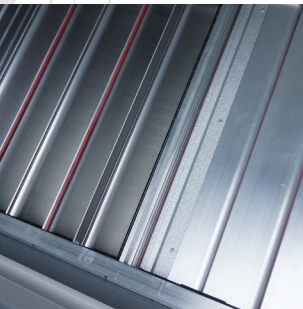
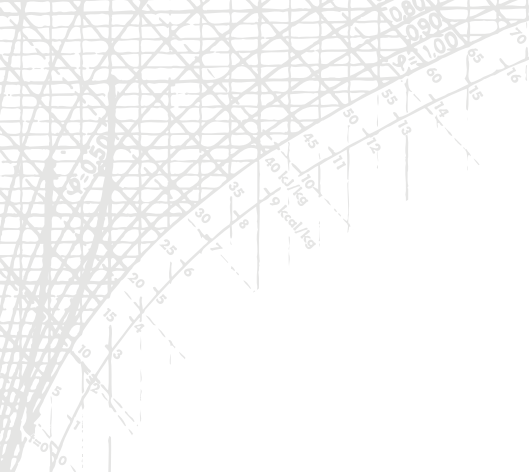

This is just part of our wide range. For our full range, see [www.ivprodukt.com](http://www.ivprodukt.com) or contact us to find out more.

## You are welcome to contact us

### Växjö

Sjöddevägen 7

SE-350 43 Växjö

Switchboard: +46 (0)470 75 88 00

Control support: +46 (0)470 75 89 00

[info@ivprodukt.se](mailto:info@ivprodukt.se)

[www.ivprodukt.com](http://www.ivprodukt.com)

### IV Produkt Ltd

Sweden House, 4th Floor,

5 Upper Montagu Street,

LONDON W1H 2AG

Phone: 020 7258 5152



*Air handling with focus on LCC*